

DRINKING FOUNTAIN

G20100N

Drinking water fountains are manufactured from grade austenitic stainless steel, material thickness 1.2mm, supplied complete with 19mm waste and water bubbler. The wall mounted model is simply fixed to the wall using a joggle strip and integral mounting brackets.

ARTICLE NUMBER

G20100N

EAN 7612979002904

TECHNICAL DATA

Material	stainless steel
Material code	1.4301 Chrome Nickel steel V2A
Material thickness	1.2 mm
Surface finish	satin finished
Gross weight	10 kg
Type of operation	manual operation
Type of mounting	wall mounting
Waste size	DN 20
Overall width	310 mm
Overall height	264 mm
Overall depth	135 mm
Bowl - width	264 mm
Bowl - depth	310 mm
Bowl - bowl depth	135 mm
Waste hole position	centre
Waste hole projection	150 mm

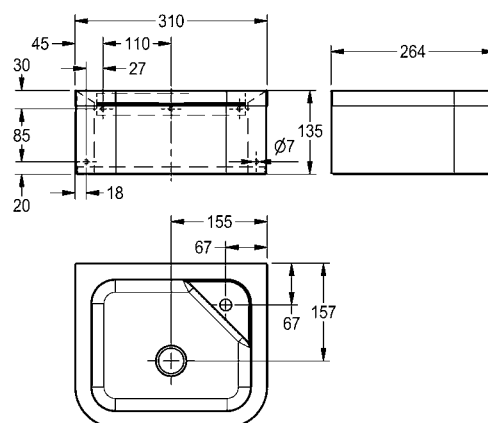

Franke Washroom Systems
ws-info.uk@franke.com
www.franke.com

2013-03-05, Franke WS