

Separators

for steam, air and gas systems



spirax
/sarco

Protect your investment in process plant and pipeline products whilst increasing productivity

Heat transfer applications

Water is an extremely effective barrier to heat transfer in steam systems. Whilst careful drainage and trapping will remove much of the water, it will not deal with water droplets in suspension.

Wet steam can, and will, cause one or more of the following problems:

- Reduction in heat transfer efficiency as shown opposite.
- Increased erosion and possible corrosion within the steam system.
- Increased scaling of pipework and heating surfaces from impurities carried in the water droplets.

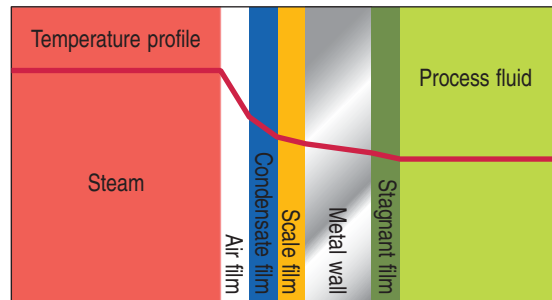

Valve and meter protection - steam, air or gas

Entrained water flowing through control valves, flowmeters and rotating or reciprocating equipment, significantly affects performance and can eventually lead to total failure and plant stoppage.

Common problems normally associated with entrained water droplets in steam, air or gas flows are:

- Erratic operation of control valves and flowmeters.
- Eroded valve seats and fittings due to high velocity water droplets, (a condition known as wire drawing).
- Ultimate failure due to rapid wear or waterhammer (e.g. broken turbine blades on air tools).

Spirax Sarco offers two solutions to the above problems:

1 Available in cast iron and SG iron, the S1, S2, S3, S12 and S13 separators are offered for general purpose applications. Designed for simplicity, they are relatively compact yet efficient for non-critical applications.

2 The S5, S6, S7 and S8 series of high efficiency separators are specifically designed to maintain separation efficiency over a wide range of pipeline velocities and pressures. These separators are available in both carbon steel and austenitic stainless steel for specialist process systems.

The Spirax Sarco separator provides the total solution for all pipelines carrying steam, air or gas where water droplets are in suspension.

Separator range Note: Certification will be provided to the requirements of the Pressure Equipment Directive.

Material	Cast iron	Cast iron	SG iron	SG iron	SG iron	Carbon steel	Austenitic stainless steel	Carbon steel	Austenitic stainless steel
Type	S2 (Page 8)	S3 (Page 8)	S13 (Page 9)	S1 (Page 10)	S12 (Page 11)	S5 (Page 12)	S6 (Page 13)	S7 (Page 14)	S8 (Page 15)
Size	DN32 - 50	DN40 - 200	DN40 - 200	DN15 - 25	DN32 - 50	DN15 - 80	DN15 - 80	DN65 - 350	DN65 - 150
Connections	Screwed	Flanged	Flanged	Screwed	Screwed	Screwed Flanged	Screwed Flanged	Flanged	Flanged

Optional extras

Insulation jacket	●	●	●	●	●	●	●		
Air vent						AV30 AV45	AV30 AV45	AV21 AV30	AV21 AV30

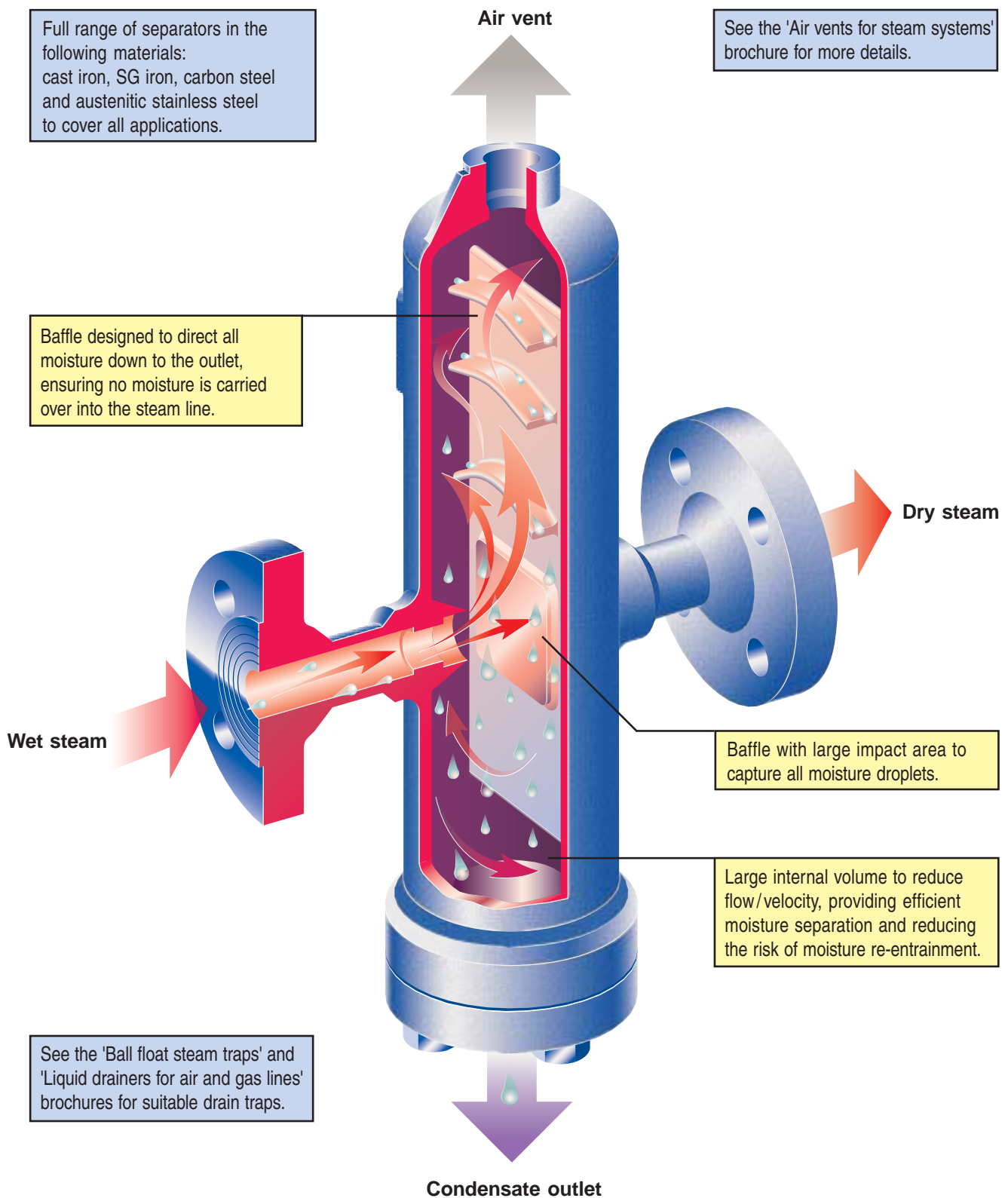

User benefits

- Improves process plant productivity and product quality.
- Reduces maintenance cost and downtime.
- Increases plant and control valve life.
- Removes risk of waterhammer damage and subsequent maintenance bills.
- Simple, robust and effective separator design requiring no maintenance.
- Wide choice of materials and connections.
- Ensures only steam, air or gas is actually metered. (When fitted to protect flowmeters).
- Spirax Sarco's worldwide guarantee of knowledge, service and technical support.

The efficient use of separators

How separators work

Separator efficiency is a measure of the weight of water separated out in proportion to the total weight of water carried along the pipeline.

There is, however, one problem, water droplets are not distributed evenly over the total cross section of the pipe. Water flowing along the bottom of the pipe is relatively easy to remove whilst droplets of varying size in suspension are more difficult.

Separators are designed to gather together the small droplets of water and then separate them from the pipeflow.

The Spirax Sarco baffle type separator is designed to achieve this separation by having an internal volume many times greater than the inlet pipework.

The flow velocity of the steam, air or gas is significantly reduced as it enters the body. The relatively heavy water droplets impact on the internal baffles and are then directed to the separator drain connection and removed from the system using either a steam trap, or when used on air or gas distribution system, a liquid drainer.

Internal volumes are optimised to ensure pressure drop across all Spirax Sarco separators are negligible.

The alternative solution is to use centrifugal type separators which are efficient over a far smaller range of velocities.

For higher velocities re-entrainment of the already separated water and higher pressure drop across the unit occur, which, in the case of steam systems, can reduce temperatures for process. In the case of compressed air systems this reduces power output in tools.

Clearly, where flowrates vary, as commonly found in steam and air systems, then the baffle type separator is ideal and must be the first choice.

The Spirax Sarco baffle type separator is a highly efficient product, operating over a wide velocity range, leading to improved system performance.

Removal of air from high efficiency separators

The baffle design and vertical shape of the S5, S6, S7 and S8 separators, provides a high efficiency method for separating liquid from a vapour or gas. These same features also provide a very effective product for the removal of air from steam lines. In fact, ensuring that air collects in the upper portion of the separator guarantees the efficient removal of air from a system, improving productivity in the steam plant.

A suitable air vent should therefore always be connected to the air vent connection.

The importance of insulation jackets

Fitting and removal of insulation jackets to the Spirax Sarco range of separators is extremely straightforward when compared to more traditional methods of insulation.

They provide three very distinct and important functions:

- **Using insulation jackets, ensures that dryness fraction and efficiency is maintained.**
- **Using insulation jackets, prevents heat transfer losses.**
- **Safety - Using insulation jackets, protects people from the possibility of injury from burns.**

Due to their design the Spirax Sarco range of insulation jackets are clean (no messy application techniques), user friendly and resistant to water, fire and abuse.

With Pressure System Regulations, inspection of wall thickness in order to monitor internal and external corrosion is becoming commonplace. Wall thickness can be quickly measured in service, (using for example an ultrasonic sensor) by simply undoing a velcro fastening or strap. This would be much more awkward with traditional lagging.

Typical applications

Steam distribution

Modern package boilers have limited steam space and evaporation surfaces which may give rise to very high steam take-off velocities and the production of wet steam under certain circumstances. When this happens the water carried over can contain impurities and water treatment chemicals all of which cause problems in the distribution system, control valves and process plant. The baffle separator removes all moisture ensuring a dry steam supply to process whilst reducing scaling in valves and on heat transfer surfaces.

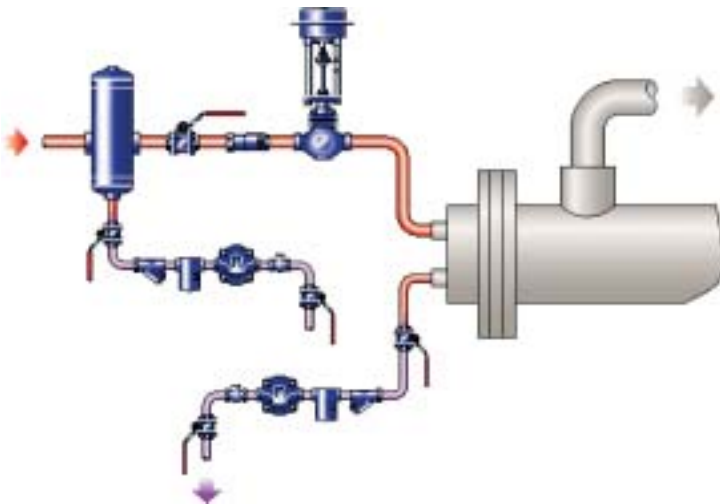
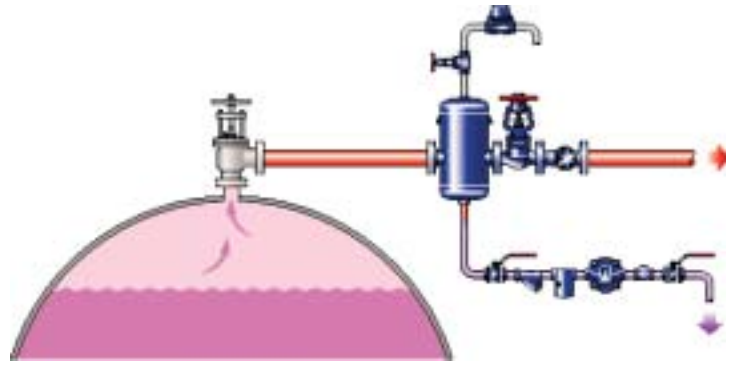

Heat transfer processes and valve protection

Conditions the steam prior to the control valve removing the possibility of valve damage under low load conditions by 'Wire drawing' when the valve cone may be working close to its seat. Improves heat transfer rates by limiting moisture film on heat transfer surfaces.



Compressed air distribution

Removes excess moisture from the air flow prior to distribution, reducing corrosion within the system and preventing possible waterhammer damage.

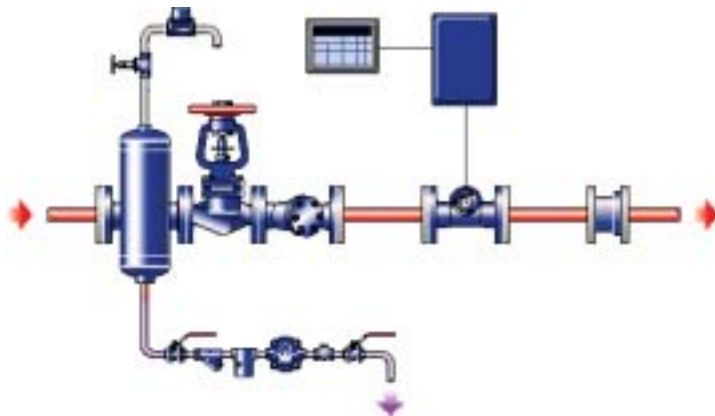

Steam meters

Removes all excess moisture prior to metering, ensuring metered figures reflect the flow of dry steam. Also ensures meter components are not subjected to damage by waterhammer.

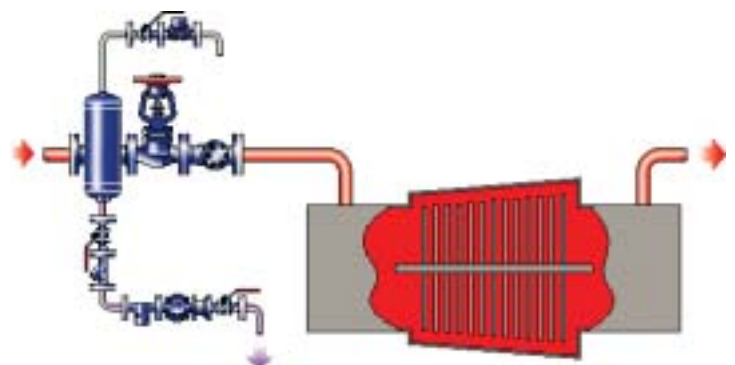

Capital equipment protection - steam turbines

By removing all water particles, the turbine is supplied with dry steam, thus protecting the turbine blades and casing from expensive erosion and waterhammer damage.

Sizing for efficient moisture separation

The relative importance of accurate sizing depends upon the separator type and application. Spirax Sarco baffle type separators have been designed with generous internal volumes giving high separation efficiency over a wide range of pipeline velocities with negligible pressure drop.

For non-critical applications such as general distribution drainage and heat transfer equipment, select a separator the same size as the pipeline. This assumes the line has been correctly sized to handle a maximum load with a recommended velocity of 30 m/s for steam and 8 m/s for air. Under these conditions, the pressure drop through the separator will be no worse than the equivalent length of pipe.

Steam sizing chart for the S5, S6, S7 and S8 separator up to DN150

Steam sizing example

1. **Plot point A** where the steam pressure and flowrates cross, e.g. 12 bar g / 500 kg/h. Draw a horizontal line.
2. **Select line size.** Any separator curve that is bisected by this line within the yellow area will operate at near 100% efficiency, e.g. DN32, point B.
3. **Ascertain velocity.** Line velocity for any size can be determined by dropping a vertical line from this intersection. From point B this line crosses the velocity axis at 18 m/s.
4. **Pressure drop.** Where the line extended from point B crosses the line C - C, plot a horizontal line. Now drop a vertical line from point A. The point of intersection, D, is the pressure drop across the separator, i.e. less than 0.05 bar.
5. **Separators should be selected on the basis of the best compromise between line size, velocity and pressure drop for each application.**

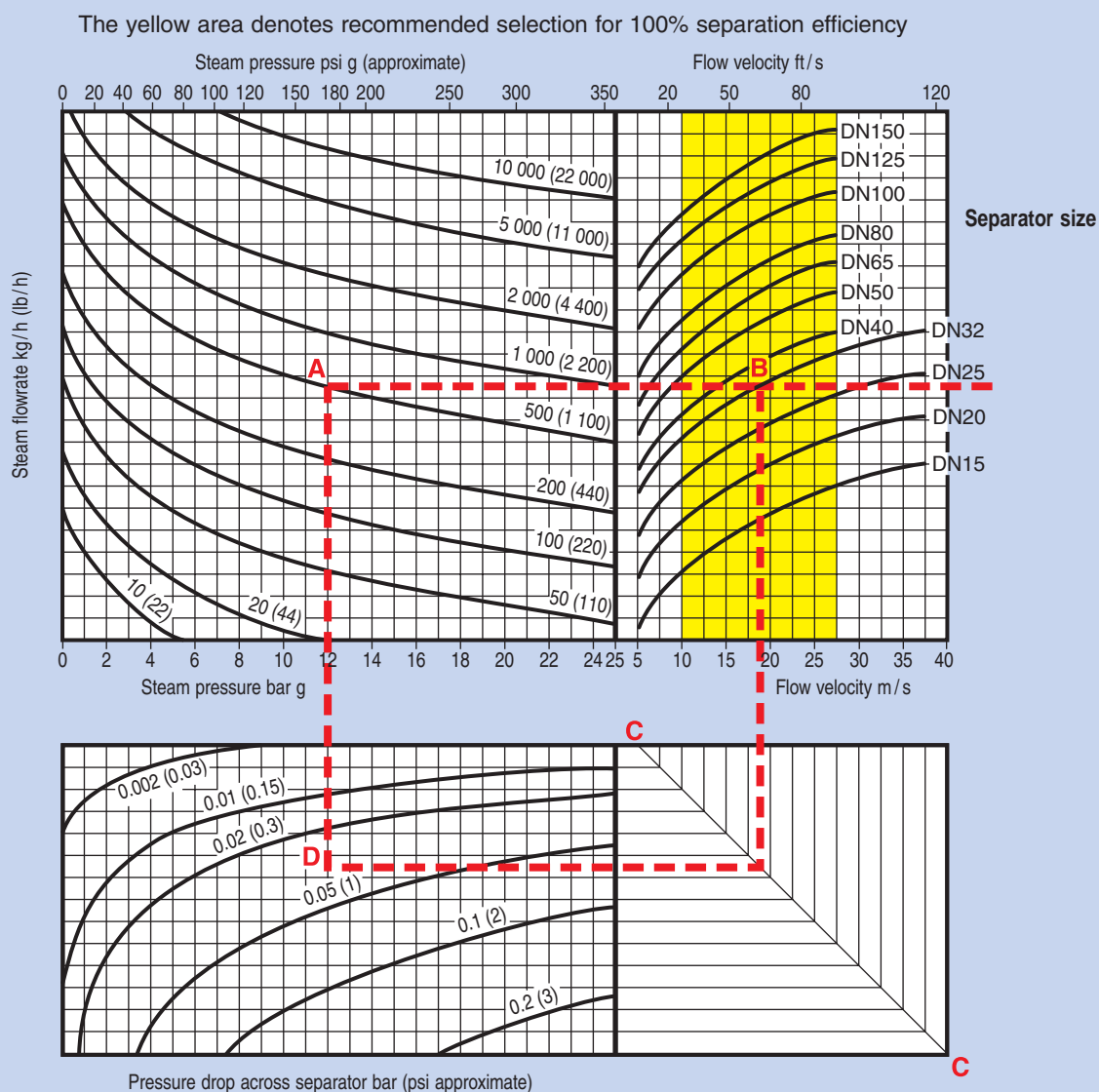

Note: For larger sizes and alternative, metals and pressure and temperatures that exceed these operating conditions please contact Spirax Sarco for a bespoke product.

For critical applications, where flowmeters or control valves have to be protected to ensure their accuracy and stability, the Spirax Sarco range of high efficiency separators are recommended.

The sizing charts below can be used to economically select the correct separator with known efficiency and pressure drop for steam.

The sizing charts allow you to select a separator based upon different sizing criteria:

Given a pressure and flowrate a separator can be selected to provide a required velocity or acceptable pressure drop. If these factors are considered to be less important than pipe size a separator can be selected which will increase the velocity and pressure drop in order to reduce the size of the separator. Considering all these variables it is always possible to ensure that the separator will provide 100% efficiency.

Air sizing chart for the S5, S6, S7 and S8 separator up to DN150

Air sizing example

1. **Plot point E** where the compressed air pressure and flowrate cross, e.g. 8 bar g / 500 dm³/s. Draw a horizontal line.
2. **Select line size.** Any separator curve that is bisected by this line within the yellow area will operate at near 100% efficiency, e.g. DN100, point **F**.
3. **Ascertain velocity.** Line velocity for any size can be determined by dropping a vertical line from this intersection. From point **F** this line crosses the velocity axis at 7 m/s.
4. **Pressure drop.** Where the line extended from point **F** crosses the line **G - G**, plot a horizontal line. Now drop a vertical line from point **E**. The point of intersection, **H**, is the pressure drop across the separator, i.e. less than 0.01 bar.
5. **Separators should be selected on the basis of the best compromise between line size, velocity and pressure drop for each application.**

The yellow area denotes recommended selection for 100% separation efficiency

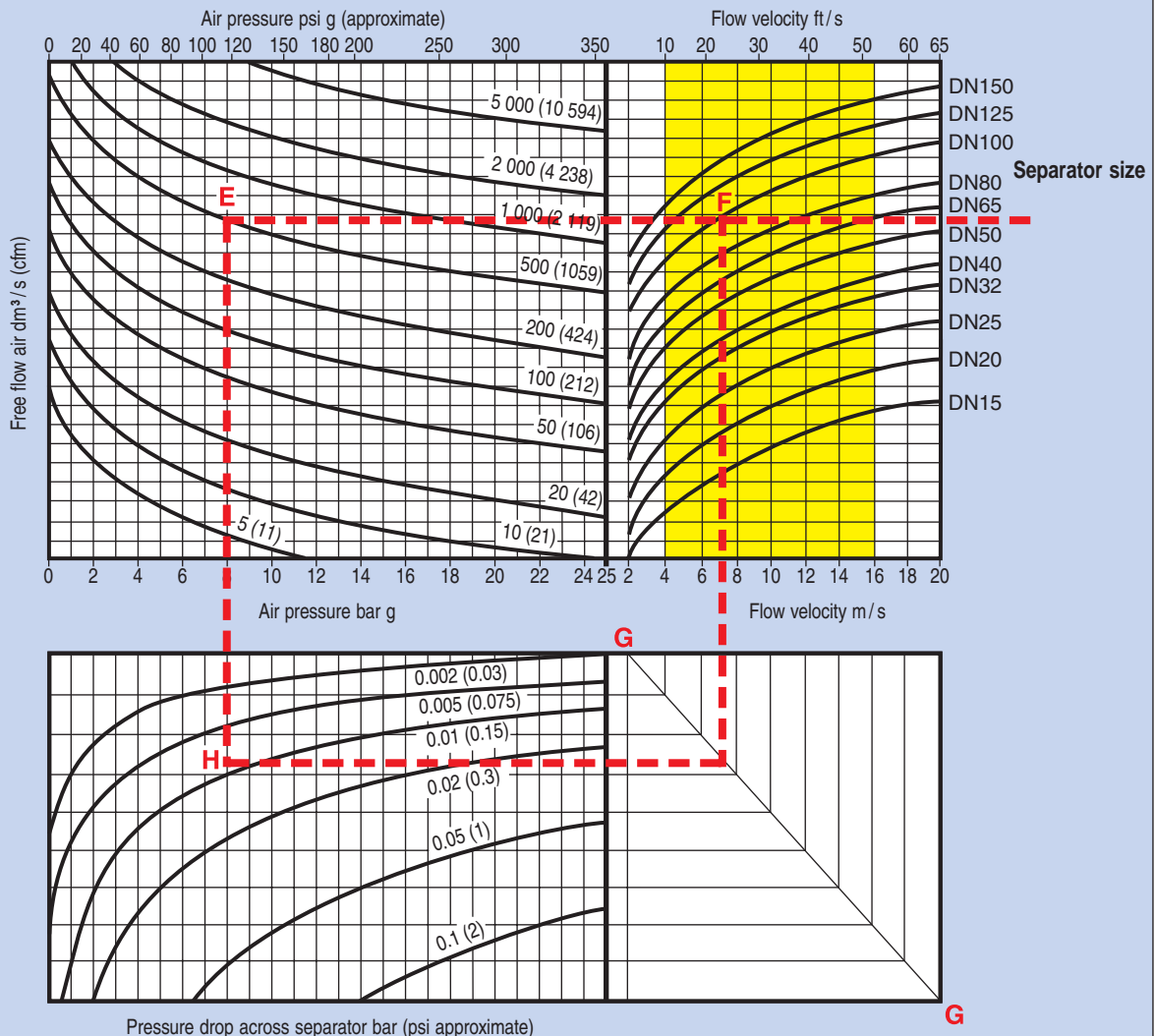

Note: For larger sizes and alternative, metals and pressure and temperatures that exceed these operating conditions please contact Spirax Sarco for a bespoke product.

Independent research carried out by Liverpool University in England, provided the experimental data from which the above graph was derived.

S2

Cast iron



Sizes and pipe connections

1¼", 1½" and 2" screwed BSP, NPT with screwed BSP or NPT drain.

Materials

Body	Cast iron	DIN 1691 GG 20 / ASTM A126 CI B
Plug 2" only	SG iron	DIN 1693 GGG 40
Gasket 2" only	Reinforced exfoliated graphite	
Drain reducing bush	Forged carbon steel	ASTM A105N

Operating range

The product must not be used in the red area.

*PMO - Maximum operating pressure for steam.

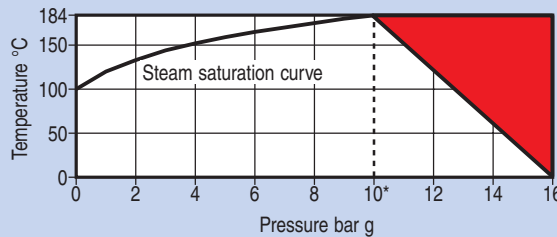

Limiting conditions

Body design conditions PN16
 PMA - Maximum allowable pressure 16 bar g
 TMA - Maximum allowable temperature 184°C
 Designed for a maximum cold hydraulic test pressure of 24 bar g

Dimensions, weights and volumes (approximate) in mm, kg and litres

Size	A	B	C	D	E	F	G	Weight	Volume
1¼"	111	156	89	304	½"	1½"	60	9.6	1.5
1½"	111	156	89	304	½"	1½"	60	9.6	1.5
2"	166	205	117	397	½"	1½"	71	19.0	3.2

Inspection opening (2" only)

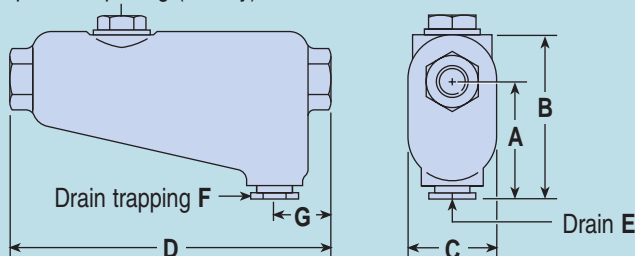

S3

Cast iron



Sizes and pipe connections

DN40, 50, 65, 80, 100, 125, 150 and
 JIS/KS 10 and AS2129 Table F (DN40 and
 BS 1560 class 125 with

Materials

Body	Cast iron	
Plug DN40 to DN100	SG iron	
Gasket DN40 to DN100	Reinforced	
Drain reducing bush (not DN200)	Forged c	

Operating range

The product must not be used in the red area.

*PMO - Maximum operating pressure for steam.

A - A PN16/Table F
 B - B JIS/KS 10
 C - C ANSI 125

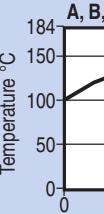

Limiting conditions

Body design conditions PN16
 PMA - Maximum allowable pressure 16 bar g
 TMA - Maximum allowable temperature 184°C
 Designed for a maximum cold hydraulic test pressure of 24 bar g

Dimensions, weights and volumes (approximate) in mm, kg and litres

Size	A	B	C	D
DN40	111	156	89	365
DN50	146	206	117	456
DN65	184	232	146	406
DN80	187	264	152	483
DN100	238	337	197	692
DN125	232	409	381	706
DN150	232	409	381	706
DN200	305	505	426	762

Inspection opening

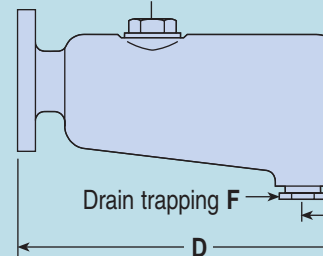



S13

SG iron



S3 Cast iron
model shown

Connections

DN40 to DN200 flanged BS 4504 (DIN) PN16, PN25 (DN100 only) with screwed BSP drain and screwed NPT drain.

Materials

Body	DIN 1691 GG 20 / ASTM A126 CI B
Plug	DIN 1693 GGG 40
Gasket	Reinforced exfoliated graphite
Drain reducing bush	Carbon steel
	ASTM A105N

Operating range

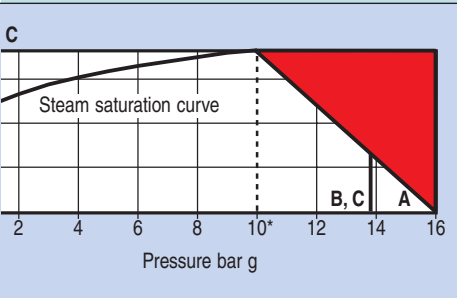

Limiting conditions

Maximum body design conditions PN16
 Maximum allowable pressure 16 bar g
 Maximum allowable temperature 184°C
 Maximum cold hydraulic test pressure of 24 bar g

Weights and volumes

(approximate) in mm, kg and litres

Size	A	B	C	D	E	F	G	Weight	Volume
1/2"	111	156	89	365	1/2"	1"	94	14.0	1.6
1/2"	146	205	117	456	1/2"	1"	98	25.4	3.2
3/4"	178	249	146	406	3/4"	1 1/2"	98	36.7	4.6
1"	178	252	152	483	1"	1 1/2"	98	44.9	6.5
1"	223	315	197	692	1"	1 1/2"	118	74.8	13.5
1"	226	397	381	706	1"	1 1/2"	121	177.8	38.5
1"	226	397	381	706	1"	1 1/2"	121	181.4	42.5
1 1/2"	308	502	426	762	1 1/2"	1 1/2"	140	254.0	68.0

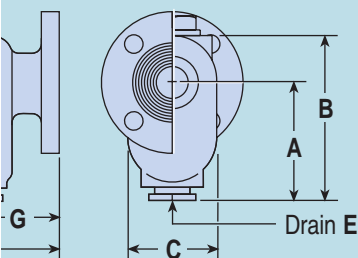

Sizes and pipe connections

DN40, 50, 65, 80, 100, 125, 150 and 200 flanged BS 4504 (DIN) PN16 and PN25, JIS/KS 10 and 20 with screwed BSP drain.

Materials

Body	SG iron	DIN 1693 GGG40/ASTM A395
Plug	DN40 to DN80	SG iron
	DN100 to DN200	Carbon steel
Gasket	Reinforced exfoliated graphite	
Drain reducing bush	Forged carbon steel	ASTM A105N

Operating range

The product must not be used in the red area.

*PMO - Maximum operating pressure for steam.

A - A JIS 10
 B - B PN16
 B - C - D PN25
 B - E - D JIS 20

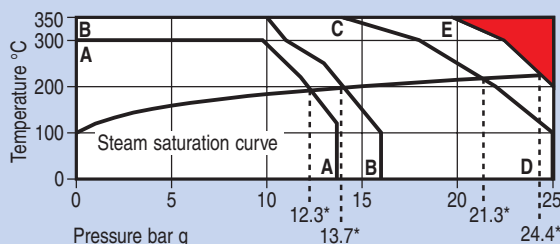

Limiting conditions

Maximum body design conditions PN25
 PMA - Maximum allowable pressure 25 bar g
 TMA - Maximum allowable temperature 350°C
 Designed for a maximum cold hydraulic test pressure of:
 PN16 24 bar g, PN25 38 bar g, JIS/KS 10 19.6 bar g, JIS/KS 20 38 bar g

Dimensions, weights and volumes

(approximate) in mm, kg and litres

Size	A	B	C	D	E	F	G	Weight	Volume
DN40	111	156	89	365	1/2"	1"	94	14	1.6
DN50	146	205	117	456	1/2"	1"	98	25	3.2
DN65	178	249	146	406	3/4"	1 1/2"	98	28	4.6
DN80	178	252	152	483	1"	1 1/2"	98	36	6.5
DN100	223	315	197	692	1"	1 1/2"	118	60	13.5
DN125	226	397	381	706	1"	1 1/2"	121	128	38.5
DN150	226	397	381	706	1"	1 1/2"	121	130	42.5
DN200	308	502	426	762	1 1/2"	1 1/2"	140	190	68.0

Inspection opening

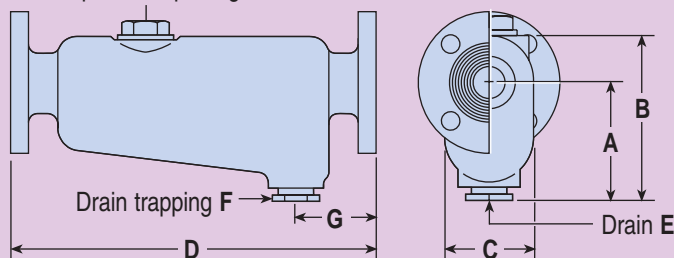

S1

SG iron



Sizes and pipe connections

1/2", 3/4" and 1" screwed BSP, NPT with screwed BSP or NPT drain.

Materials

Body and cover	SG iron	DIN 1693 Gr. GGG 40
Gasket	Semi-rigid graphite laminate	
Bolts	Steel	BS 1768 Gr. 5
Bush	1/2" - 3/4" Malleable iron	
	1" Forged carbon steel	ASTM A105N
Baffle	Cast iron	DIN 1691 Gr. GG20

Operating range

The product must not be used in the red area.
*PMO - Maximum operating pressure for steam.

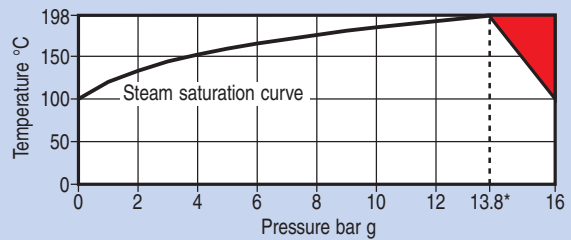

Limiting conditions

Body design conditions PN16
PMA - Maximum allowable pressure 16 bar g
TMA - Maximum allowable temperature 300°C
Designed for a maximum cold hydraulic test pressure of 24 bar g

Dimensions, weights and volumes (approximate) in mm, kg and litres

Size	A	B	C	D	E	F	Weight	Volume
1/2"	124	225	86	88	1/2"	1"	2.7	0.53
3/4"	156	260	110	113	1/2"	1 1/2"	4.2	1.13
1"	222	377	143	152	1/2"	2"	8.1	3.15

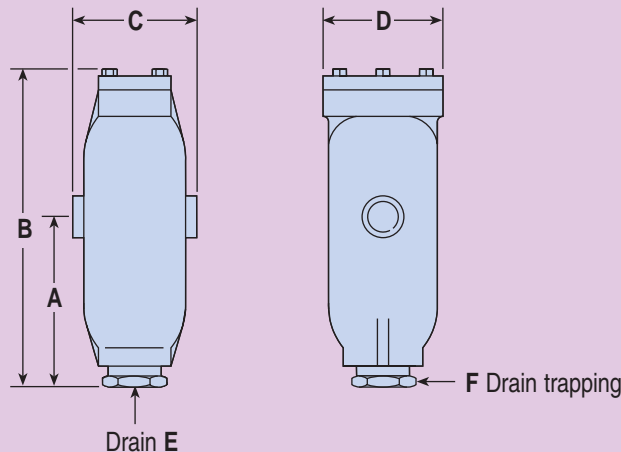

S12

SG iron



Sizes and pipe connections

1¼", 1½" and 2" screwed BSP, NPT with screwed BSP or NPT drain.

Materials

Body		SG iron	DIN 1693 GGG 40/ASTM A395
Plug	2" only	SG iron	DIN 1693 GGG 40
Gasket	2" only	Reinforced exfoliated graphite	
Drain reducing bush		Forged carbon steel	ASTM A105N

Operating range

The product must not be used in the red area.
*PMO - Maximum operating pressure for steam.

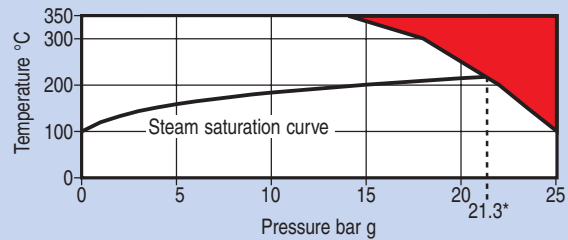

Limiting conditions

Body design conditions PN25
PMA - Maximum allowable pressure 25 bar g
TMA - Maximum allowable temperature 350°C
Designed for a maximum cold hydraulic test pressure of 38 bar g

Dimensions, weights and volumes (approximate) in mm, kg and litres

Size	A	B	C	D	E	F	G	Weight	Volume
1¼"	111	156	89	304	½"	1"	60	9.0	1.5
1½"	111	156	89	304	½"	1"	60	9.0	1.5
2"	146	205	117	397	½"	1"	71	17.0	3.2

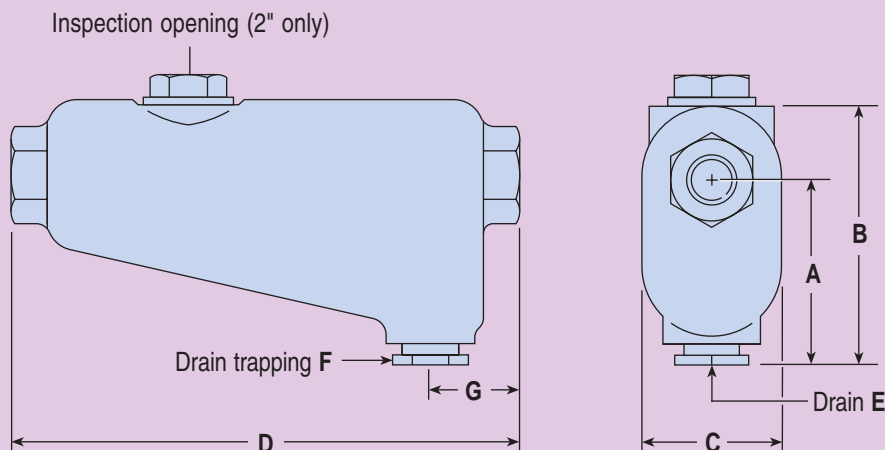

S5

Carbon
steel



Sizes and pipe connections

1/2", 3/4", 1", 1 1/4", 1 1/2", 2", 2 1/2" and 3" screwed BSP or NPT, butt weld (BW) or socket weld (SW).
DN15, 20, 25, 32, 40, 50, 65 and 80 flanged BS 4504 (DIN) PN40, JIS/KS 10K and 20K with screwed BSP drain and air vent
and BS 1560 (ANSI B 16.5) Class 150 or 300 with screwed NPT drain and air vent.

Materials

Body	Carbon steel	DIN 17245 GS C25N / ASTM A216 WCB	
Flange	PN	Carbon steel	DIN 17243 C22.8
	ANSI/JIS/KS	Carbon steel	ASTM A105N
Cover	Carbon steel	DIN 17245 C22.8 (1.0460) / ASTM A105N	
Cover gasket	Reinforced exfoliated graphite		
Bolt	Steel	BS 3692	

Operating range

The product must not be used in the red area.
*PMO - Maximum operating pressure for steam.

- A - A Flanged JIS/KS 10K
- B - B Flanged ANSI Class 150
- C - C Flanged JIS/KS 20K
- D - D Flanged DIN PN40
- E - E Flanged ANSI Class 300, Screwed BSP/NPT, SW, BW

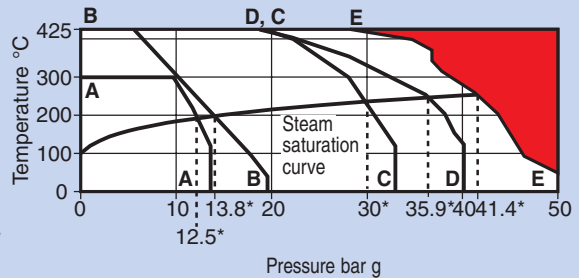

Limiting conditions

Maximum body design conditions PN50/ANSI 300

PMA - Maximum allowable pressure 50 bar g

TMA - Maximum allowable temperature 425°C

Designed for a maximum cold hydraulic test pressure of:

JIS/KS 10K - 20 bar g, JIS/KS 20K - 49 bar g, DIN PN40 - 60 bar g

ANSI Class 150 - 30 bar g, ANSI Class 300 - 76 bar g, Screwed, SW, BW - 76 bar g.

Dimensions, weights and volumes

(approximate) in mm, kg and litres

Size	Screwed		JIS / KS				Weight		Volume				
	SW	PN40	ANSI 150	ANSI 300	10K & 20K	A	B	C	D	G	Scrd SW	Scrd Flgd	
	A	A	A	A	A								
DN15-1/2"	130	204	204	204	204	162	292	90	1/2"	3.3	4.5	0.84	0.85
DN20-3/4"	130	212	212	212	212	158	345	90	1/2"	3.8	5.0	1.00	1.03
DN25-1"	178	260	260	260	260	184	387	90	1/2"	7.0	9.5	2.50	2.60
DN32-1 1/4"	190	274	304	320	274	209	438	90	1/2"	14.0	19.0	4.50	4.60
DN40-1 1/2"	220	310	344	396	310	221	508	90	1"	22.0	27.0	7.70	7.90
DN50-2"	214	310	342	354	310	221	558	90	1"	23.0	29.0	8.40	8.70
DN65-2 1/2"	319	419	419	419	419	270	663	90	3/4"	65.0	70.0	17.50	18.00
DN80-3"	379	489	489	489	489	329	764	90	3/4"	82.0	90.0	31.00	32.00

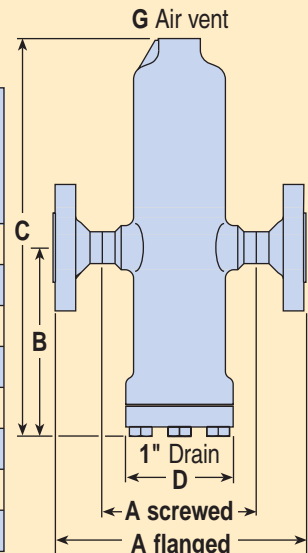

S6

Austenitic stainless steel



S5 carbon steel model shown

Sizes and pipe connections

1/2", 3/4", 1", 1 1/4", 1 1/2", 2", 2 1/2" and 3" screwed BSP or NPT, butt weld (BW) or socket weld (SW).
 DN15, 20, 25, 32, 40, 50, 65 and 80 flanged BS 4504 (DIN) PN40, JIS/KS 10K and 20K with screwed BSP drain and air vent and BS 1560 (ANSI B 16.5) Class 150 or 300 with screwed NPT drain and air vent.

Materials

Body	Austenitic stainless steel 316L	DIN 17445 Gx5 CrNi MoNb 1810 (werkstoff no. 1.4581)/ASTM A351 CF3M
Flange	PN	Austenitic stainless steel DIN 17440 x2CrNi Mo 17 13 2 stainless steel (werkstoff no. 1.4404)
	ANSI/JIS/KS	Austenitic stainless steel ASTM A182 F316L
Cover	Stainless steel	DIN 17440 x2CrNi Mo (1.4404)/ASTM A182 F316L
Cover gasket	Reinforced exfoliated graphite	
Bolt	Stainless steel	BS ENO 150 35 08 - 1: 1998 Grade A4-80

Operating range

The product must not be used in the red area.
 *PMO - Maximum operating pressure for steam.

- A - A Flanged JIS/KS 10K
- B - B Flanged ANSI Class 150
- C - C Flanged JIS/KS 20K
- D - D Flanged DIN PN40
- E - E Flanged ANSI Class 300
- F - F Screwed BSP/NPT, SW, BW

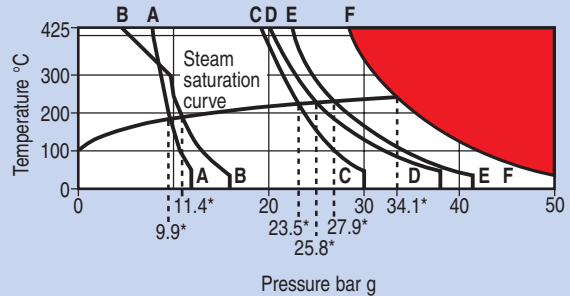

Limiting conditions

Maximum body design conditions PN50/ANSI 300

PMA - Maximum allowable pressure 50 bar g

TMA - Maximum allowable temperature 425°C

Designed for a maximum cold hydraulic test pressure of:

JIS/KS 10K - 20 bar g, JIS/KS 20K - 49 bar g, DIN PN40 - 60 bar g

ANSI Class 150 - 30 bar g, ANSI Class 300 - 76 bar g, Screwed, SW, BW - 76 bar g.

Dimensions, weights and volumes

(approximate) in mm, kg and litres

Size	Screwed		JIS / KS				Weight		Volume	
	SW	PN40	ANSI 150	ANSI 300	10K & 20K	Scrd	Flgd	Scrd	Flgd	
	A	A	A	A	A B C D G	BW	Flgd	BW	Flgd	
DN15-1/2"	130	204	204	204	204 162 292 90 1/2"	3.3	4.5	0.84	0.85	
DN20-3/4"	130	212	212	212	212 158 345 90 1/2"	3.8	5.0	1.00	1.03	
DN25-1"	178	260	260	260	260 184 387 90 1/2"	7.0	9.5	2.50	2.60	
DN32-1 1/4"	190	274	304	320	274 209 438 90 1/2"	14.0	19.0	4.50	4.60	
DN40-1 1/2"	220	310	344	396	310 221 508 90 1"	22.0	27.0	7.70	7.90	
DN50-2"	214	310	342	354	310 221 558 90 1"	23.0	29.0	8.40	8.70	
DN65-2 1/2"	319	419	419	419	419 270 663 90 3/4"	65.0	70.0	17.50	18.00	
DN80-3"	379	489	489	489	489 329 764 90 3/4"	82.0	90.0	31.00	32.00	

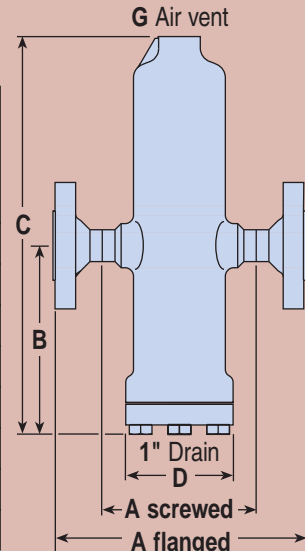

S7

Carbon steel



Sizes and pipe connections

DN65, 80, 100, 125, 150, 200, 250, 300 and 350 flanged BS 4504 (DIN) PN16 or PN40 with screwed BSP drain and air vent and flanged BS 1560 (ANSI B 16.5) Class 150 or 300 with screwed NPT drain and air vent.

Materials

Carbon steel throughout

Limiting conditions

Size	Flange standard	Design pressure bar g	Design temperature °C	Designed for a maximum cold hydraulic test pressure of: bar g	
				Shop	Site
DN65	Class 150	14	198	26.2	23.0
	PN16	14	198	24.0	23.0
	PN40/Class 300	25	225	49.1	43.1
DN80	Class 150	14	198	25.7	23.0
	PN16	14	198	24.0	23.0
	PN40/Class 300	20	213	38.0	33.9
DN100	Class 150	14	198	25.7	23.0
	PN16	14	198	24.0	23.0
	PN40/Class 300	20	213	37.9	33.9
DN125	Class 150	14	198	25.7	23.0
	PN16	14	198	24.0	23.0
	PN40/Class 300	30	236	58.3	53.1
DN150	Class 150	14	198	25.7	23.0
	PN16	14	198	24.0	23.0
	PN40/Class 300	30	236	59.3	53.1
DN200	PN16/Class 150	6	165	10.7	9.0
	PN16/Class 150	14	198	23.4	21.0
	PN40/Class 300	30	236	52.7	47.4
DN250	PN16/Class 150	6	165	10.7	9.0
	PN16/Class 150	14	198	22.7	21.0
	PN40/Class 300	30	236	51.8	47.4
DN300	PN16/Class 150	6	165	10.3	9.0
	PN16/Class 150	14	198	22.7	21.0
	PN40/Class 300	30	236	51.8	47.4
DN350	PN16/Class 150	6	165	10.3	9.0
	PN16/Class 150	14	198	22.7	21.0
	PN40/Class 300	30	236	50.6	47.4

Dimensions, weights and volumes (approximate) in mm, kg and litres

Size	Design pressure (bar g)	A	B	C	D	E	F	G	H	J	K	Weight	Volume
DN65	14	420	252	638	219	159	1"	3/4"	100	263	30	47	18
	25	420	252	638	219	159	1"	3/4"	100	263	30	49	18
DN80	14	523	332	735	273	145	2"	3/4"	125	368	30	80	33
	20	523	332	735	273	145	2"	3/4"	125	368	30	88	33
DN100	14	574	337	795	324	163	2"	3/4"	125	384	40	98	51
	20	574	337	795	324	163	2"	3/4"	125	384	40	106	51
DN125	14	656	310	843	356	230	2"	3/4"	150	416	44	115	67
	30	656	310	843	356	230	2"	3/4"	150	416	44	134	67
DN150	14	706	347	935	406	246	2"	3/4"	150	466	60	154	96
	30	706	347	935	406	246	2"	3/4"	150	466	60	172	96
DN200	6	850	460	1 200	500	372	2"	2"	175	560	60	275	185
	14	850	460	1 200	500	372	2"	2"	175	560	60	280	185
DN250	6	858	459	1 200	508	372	2"	2"	175	568	60	280	230
	14	950	615	1 580	600	530	2"	2"	175	688	72	475	333
DN300	6	950	615	1 580	600	530	2"	2"	175	688	72	475	333
	14	960	615	1 580	610	530	2"	2"	175	698	72	475	333
DN350	6	1 000	740	1 700	600	540	2"	2"	200	688	72	500	330
	14	1 000	740	1 700	600	540	2"	2"	200	688	72	500	330
DN350	30	1 010	740	1 700	610	540	2"	2"	200	698	72	500	330
	6/14/30	1 100	754	1 800	700	525	2"	2"	200	816	108	550	537

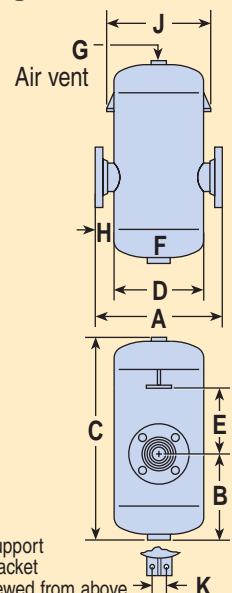

S8

**Austenitic
stainless steel**



**S7 carbon steel
model shown**

Sizes and pipe connections

DN65, 80, 100, 125, 150, 200, 250, 300 and 350 flanged BS 4504 (DIN) PN16 or PN40 with screwed BSP drain and air vent and flanged BS 1560 (ANSI B 16.5) Class 150 or 300 with screwed NPT drain and air vent.

Materials

Austenitic stainless steel throughout

Limiting conditions

Size	Flange standard	Design pressure bar g	Design temperature °C	Designed for a maximum cold hydraulic test pressure of: bar g
DN65	PN16	10	198	17.1
DN80	Class 150	11	198	18.8
DN100	PN40	25	236	44.9
DN125	Class 300	27	236	48.5
DN150		6	165	9.7
DN200	PN16	10	198	17.1
DN250	Class 150	11	198	18.8
DN300	PN40	25	236	44.9
DN350	Class 300	27	236	48.5

Note: For pressures and temperatures that exceed these operating conditions please contact Spirax Sarco for a bespoke product.

Dimensions, weights and volumes (approximate) in mm, kg and litres

Size	Design pressure (bar g)	A	B	C	D	E	F	G	H	J	K	Weight	Volume
DN65	10	420	252	638	219	149	1"	3/4"	100	263	30	47	18
	11	420	252	638	219	149	1"	3/4"	100	263	30	48	18
	25	420	252	638	219	149	1"	3/4"	100	263	30	47	18
	27	420	252	638	219	149	1"	3/4"	100	263	30	49	18
DN80	10	523	332	735	273	146	2"	3/4"	125	368	30	62	34
	11	523	332	735	273	146	2"	3/4"	125	368	30	64	34
	25	523	332	735	273	146	2"	3/4"	125	368	30	64	34
DN100	27	523	332	735	273	146	2"	3/4"	125	368	30	74	33
	10	574	337	795	324	149	2"	3/4"	125	384	40	85	53
	11	574	337	795	324	149	2"	3/4"	125	384	40	88	53
DN125	25	574	337	795	324	149	2"	3/4"	125	384	40	88	53
	27	574	337	795	324	149	2"	3/4"	125	384	40	104	52
	10	656	305	843	356	228	2"	3/4"	150	416	44	99	69
DN150	11	656	305	843	356	228	2"	3/4"	150	416	44	101	69
	25	656	305	843	356	218	2"	3/4"	150	416	44	120	67
	27	656	305	843	356	218	2"	3/4"	150	416	44	129	68
DN200	10	706	347	935	406	235	2"	3/4"	150	466	60	130	99
	11	706	347	935	406	235	2"	3/4"	150	466	60	131	99
	25	706	347	935	406	235	2"	3/4"	150	466	60	185	96
DN250	27	706	347	935	406	235	2"	3/4"	150	466	60	173	98
	6	858	399	1 200	508	371	2"	2"	175	560	60	189	207
	10	858	399	1 200	508	371	2"	2"	175	560	60	214	202
DN300	11	858	399	1 200	508	371	2"	2"	175	560	60	220	202
	25	858	399	1 200	508	359	2"	2"	175	568	60	315	195
	27	858	399	1 200	508	359	2"	2"	175	568	60	304	195
DN350	6	960	651	1 580	610	517	2"	2"	175	688	72	251	406
	10	960	651	1 580	610	507	2"	2"	175	688	72	337	396
	11	960	651	1 580	610	507	2"	2"	175	688	72	346	396
DN350	25	960	661	1 580	610	489	2"	2"	175	698	72	593	376
	27	960	661	1 580	610	489	2"	2"	175	698	72	607	376
	6	1 010	669	1 700	610	548	2"	2"	200	688	72	289	436
DN350	10	1 010	669	1 700	610	550	2"	2"	200	688	72	392	430
	11	1 010	669	1 700	610	550	2"	2"	200	688	72	411	408
	25	1 010	678	1 700	610	532	2"	2"	200	698	72	676	408
DN350	27	1 010	678	1 700	610	532	2"	2"	200	698	72	691	408
	6	1 100	750	1 800	700	520	2"	2"	200	816	108	354	610
	10	1 100	750	1 800	700	520	2"	2"	200	816	108	497	600
DN350	11	1 100	750	1 800	700	520	2"	2"	200	816	108	512	600
	25	1 100	764	1 800	700	492	2"	2"	200	816	108	971	565
	27	1 100	764	1 800	700	492	2"	2"	200	816	108	983	553

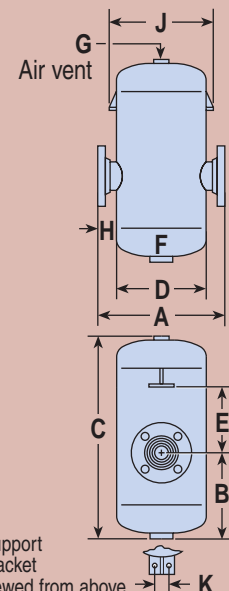

IJ-S1, IJ-S2, IJ-S3, IJ-S12 and IJ-S13

Insulation jackets for the S1, S2, S3, S12 and S13 separators



IJ-S2 model shown above

Available types

The IJ-S1, IJ-S2, IJ-S3, IJ-S12 and IJ-S13 are a range of one piece design insulation jackets available with velcro fastenings for fitting to S1, S2, S3, S12 and S13 separators.

Materials

Inner and outer face	Silicone rubber coated glass fibre
Insulation	Mineral fibre
Stitching	Polyester cotton
Sealing	Velcro
Drawcords	Nylon
Label	Nylon

Limiting conditions

Maximum metal surface temperature 220°C
Thermal conductivity 0.044 W/mK at 100°C

IJ-S5 and IJ-S6

Insulation jackets for the S5 and S6 separators



Available types

The IJ-S5 and IJ-S6 are one piece design insulation jackets for fitting to all S5 and S6 separators available in two versions: IJ-S5/6 a low temperature version (with velcro fastenings) or IJ-S5/6-H a high temperature version (with strap/buckle fastening).

Materials

Inner and outer face	IJ-S5/6	Silicone rubber coated glass fibre
	IJ-S5/6-H	Glass fibre
Insulation	IJ-S5/6	Mineral fibre
	IJ-S5/6-H	Mineral fibre
Stitching	IJ-S5/6	Polyester cotton
	IJ-S5/6-H	Kevlar cotton
Sealing	IJ-S5/6	Velcro
	IJ-S5/6-H	Glass fibre/stainless steel buckles
Drawcords	IJ-S5/6	Nylon
	IJ-S5/6-H	Kevlar
Label	IJ-S5/6 and IJ-S5/6-H	Nylon

Limiting conditions

IJ-S5/S6 - Maximum metal surface temperature 220°C
IJ-S5/S6-H - Maximum metal surface temperature 425°C
Thermal conductivity 0.044 W/mK at 100°C

Note: Other insulation jackets may be available on request. Please contact Spirax Sarco for more information

Some of the products shown may not be available in certain markets.

1110

Spirax-Sarco Limited, Charlton House,
Cheltenham, Gloucestershire, GL53 8ER UK.
Tel: +44 (0)1242 521361 Fax: +44 (0)1242 573342
E-mail: Enquiries@SpiraxSarco.com
Internet: www.SpiraxSarco.com

© Copyright 2001 Spirax Sarco is a registered trademark of Spirax-Sarco Limited

spirax
sarco

SB-S33-01

ST Issue 6