

# Technical data sheet

## Type 402

### Non return valve

### System 02

#### Applications and special features



- Operates in any position
- Minimum head loss
- Silent, reliable sealing, compact
- Exceptional robustness
- Does not generate hammering
- Notch provided for cable to submerged pumps until DN 100.
- Closing system : long back axial guiding for reduced displacement
- Sealing guaranteed by a flat seal
- Return spring

#### Technical description

##### Important notice:

The indicated pressure for the different categories of fluids (L1/L2/G1/G2) is under no condition a guarantee of use. Therefore, it is essential to validate the use of products under given operating conditions. In order to facilitate your choice regarding these new regulatory requirements, Danfoss Socla has put the necessary information concerning products with CE marking, specification sheets and product identification plates at your disposal in the price list (+ see additional explanations on the detachable slip). In addition, the operating instructions are available on our web site [www.danfoss-socla.com](http://www.danfoss-socla.com) or by requesting from our sales department.

DN	PN	PFA in bar	PS in bar				Cat	Ref.	Vvs-nr
			L1	L2	G1	G2			
1 <sup>1/2</sup>	40	10/16	16	16	16	16	I	149B2281	
2	50	10/16	16	16	16	16	I	149B2282	
2 <sup>1/4</sup>	60	10/16	16	16	16	16	I	149B1176	
2 <sup>1/2</sup>	65	10/16	16	16	15	16	I	149B2283	
3	80	10/16	16	16	12	16	I	149B2284	
3	80	10/16	16	16	16	16	II	149B2284C2	
4	100	10/16	16	16	10	16	I	149B2285	
4	100	10/16	16	16	16	16	II	149B2285C2	
5	125	10/16	16	16	0,5	16	I	149B2226	
5	125	10/16	16	16	16	16	II	149B2226C2	
6	150	10/16	16	13	0,5	16	I	149B2227	
6	150	10/16	16	16	16	16	II	149B2227C2	
8	200	10	10	10	10	10	II	149B2229	
10	250	10	10	10	10	10	II	149B2230	
12	300	10	10	10	10	10	II	149B2231	
14	350	10	10	10	0,5	10	II	149B2232	
16	400	10	10	10	0,5	10	II	149B2233	
20	500	10	10	10	0,5	10	II	149B2235	

- **Connection** : flanges drilled PN : see table
- **Permissible operating pressure PFA - water-** (for supply, distribution and disposal of water) : See table
- **Maximum Permissible pressure PS - other mediums:** See table
- **T° :** Mini. -10 °C  
Maxi. 100 °C
- **Mediums** : Clear liquids
- **Approvals** : VERITAS (France) - ACS (France)  
VA (Denmark) - WRAS (UK)  
CE Conformity (Europe)
- **International construction Standards :**  
CE Conformity Directive 97/23/CE  
Flange drilling according to EN1092-2

#### Overall dimensions

DN	B	C	D	Weight	
				mm	kg
1 <sup>1/2</sup>	40	85	80	150	4,2
2	50	100	97	165	5,8
2 <sup>1/4</sup>	60	120	125	185	8,1
2 <sup>1/2</sup>	65	120	125	185	8,1
3	80	140	150	200	10,2
4	100	170	187	220	14,5
5	125	200	220	250	24
6	150	230	250	285	32
8	200	289	340	340	53
10	250	354	420	405	94
12	300	396	490	460	140
14	350	473	586	533	225
16	400	560	680	597	312
20	500	750	880	670	540

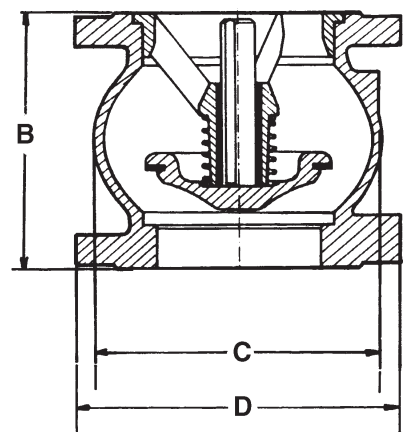

# Technical data sheet Type 402 - Non return valve

## Spare parts list and materials

Nb	Description	Materials	EURO	ANSI
1	CASING	Cast iron + epoxy	EN-GJL-250	ASTM A 48 35 B
2	RING	Bronze	CuSn12-C	
3	GUIDE DN50	Bronze	CuSn5Zn5Pb5-C	
	Other DN	Cast iron + epoxy	EN-GJL-250	ASTM A 48 35 B
4	SPRING	Stainless steel	X10CrNi18-8	AISI 302
5	SEAL	EPDM		
6	CLOSING SYSTEM DN 40	Brass	CuZn40Pb2	ASTM
	DN 50-65	Bronze	CuSn5Zn5Pb5-C	ASTM B 505
	Other DN	Cast iron + epoxy	EN-GJL-250	ASTM A 48 35 B
7	STEM	Bronze	CuSn5Zn5Pb5-C	ASTM B 505

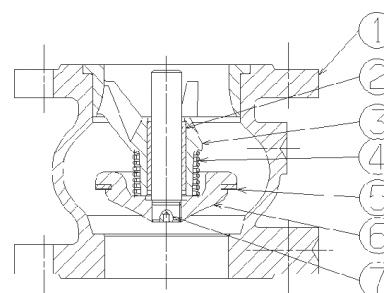

## Working principle

DN	mm	Opening pressure in mm/CE				Kv m³/H	ζ
		↑	↓	↔	without spring		
1 1/2	40	440	210	320	120	47,00	1,80
2	50	440	220	330	110	99,00	1,00
2 1/4	60	450	190	320	130	159,00	1,10
2 1/2	65	450	190	320	130	159,00	1,10
3	80	450	190	320	130	222,00	1,30
4	100	500	240	370	130	396,00	1,00
5	125	510	210	360	150	619,00	1,00
6	150	550	210	380	170	890,00	1,00
8	200	590	210	400	190	1120,00	2,00
10	250	710	210	460	250	2010,00	1,50
12	300	820	90	460	365	2459,00	2,10
14	350	860	100	480	380	2843,00	2,90
16	400	800	50	410	390	4370,00	2,10
20	500	1030	0	430	580	6914,00	2,05

### Direction for use :

- Solid line : Valve completely open
- Dotted line : opening stage of valve

ΔP

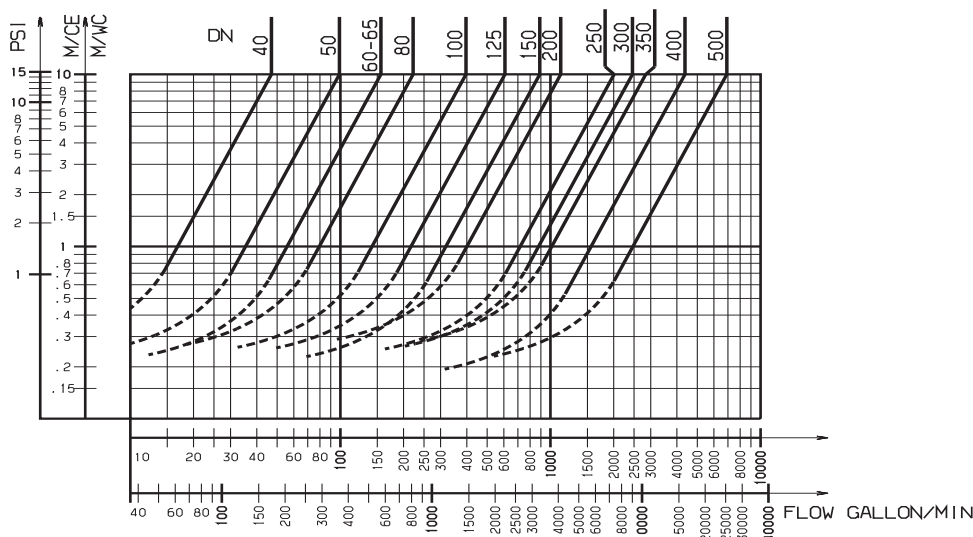

Danfoss can accept no responsibility for possible errors in catalogue, brochures and other printed material. Danfoss reserve the right to alter its products without notice. This also applies to products already agreed. All trademarks in this material are the property of the respective companies. Danfoss and the logo type are trademarks of Danfoss A/S. All right reserved.



## Danfoss Socla

365 rue du lieutenant Putier  
 71530 VIREY LE GRAND  
 Postal address : BP273  
 71107 CHALON SUR SAONE Cedex

Tel : 33 3 85 97 42 52  
 Fax : 33 3 85 97 97 42  
<http://www.danfoss-socla.com>  
 e-mail: [commerfr@danfoss.com](mailto:commerfr@danfoss.com)