



Synco™ 100

## Air Duct Temperature Controller

## RLM162

with 2 outputs DC 0...10 V

---

**Air duct temperature controller for supply and extract air temperature control in basic ventilation and air conditioning plants. Compact design with 2 analog control outputs DC 0...10 V for heating and/or cooling.**

### Use

---

Plant types:

- Small ventilation or air conditioning plants
- Zones of ventilation or air conditioning plants with central air handling

Building types:

- Small residential buildings with own air handling
- Non-residential buildings of all types
- Apartments with a suitable reference room
- Individual rooms (e.g. conference rooms, training centers)

Devices that can be controlled:

- Heating valve actuators
- Cooling valve actuators
- Air damper actuators
- Current valves of electric air heater batteries

## Functions

---

### Main function

- Modulating control of the supply or extract air temperature (P- or PI-mode) through control of the actuating device on the water- or air-side with selectable operating action of the control signals for heating only or cooling only or for heating and cooling

### Other functions

- Outside temperature compensation
- Minimum limitation of the supply air temperature
- Remote setpoint adjustment
- Setpoint readjustment
- Setpoint changeover via external contact
- Load-dependent switching contact (e.g. for switching a second stage on)
- Test mode as a commissioning aid

## Ordering

---

When ordering, please give type reference **RLM162**.

## Equipment combinations

---

Actuators and controls must meet the following specification:

- Control input: modulating, DC 0...10 V
- Operating voltage: AC 24 V

For auxiliary functions, the following products can be used:

<i>Type of unit</i>	<i>Type ref.</i>	<i>Data Sheet</i>
Room temperature controller (as a minimum limiter)	<b>RLA162</b>	N3331
Outside sensor (for outside temperature compensation)	<b>QAC22</b>	N1811
Remote setpoint adjuster (scale 0...50 °C)	<b>BSG21.1</b>	N1991
Additional scale -5...+5 K for remote setpoint adjuster	<b>BSG-Z</b>	N1991

## Technical design

---

### Application

- 1-stage heating
- 1-stage cooling
- 2-stage heating
- 1-stage heating and 1-stage cooling

### Temperature control

#### Settings

The following settings are required:

- Supply air or extract air temperature setpoint
- Operating action: the 2 control outputs Y1 and Y2 can act as follows:
  - 1-stage heating: control output Y2 is not used
  - 1-stage cooling: the second control output Y2 is not used
  - 2-stage heating: both control outputs have the same operating action and operate in sequence
  - 1-stage heating and 1-stage cooling: the control outputs have opposed operating actions; the dead zone is fixed at 1.5 K
- Control mode: to match the controller to the type of controlled system, 4 choices are available:
  - P-mode; suited for extract air temperature control
  - PI mode with a fixed integral action time of 600 seconds (SLOW); suited for extract air temperature control
  - PI mode with a fixed integral action time of 180 seconds (MEDIUM); suited for supply air temperature control

- PI mode with a fixed integral action time of 120 seconds (FAST); suited for supply air temperature control with fast controlled systems
- P-band: the P-band of control output Y1 is adjustable.
  - For Y2, the following applies:
    - With operating action heating, the P-band of Y2 is identical to the P-band of Y1
    - With operating action cooling, the P-band of Y2 is 50 % of the P-band of Y1

**Control**

The RLM162 temperature controller compares the air duct temperature acquired by the sensor (integrated in the controller) with the setpoint. If there is a deviation, the controller generates a DC 0...10 V control signal to adjust the regulating unit(s) between 0...100 %. In P-mode, the output is proportional to the offset, in PI mode the output is proportional to the heating or cooling load.

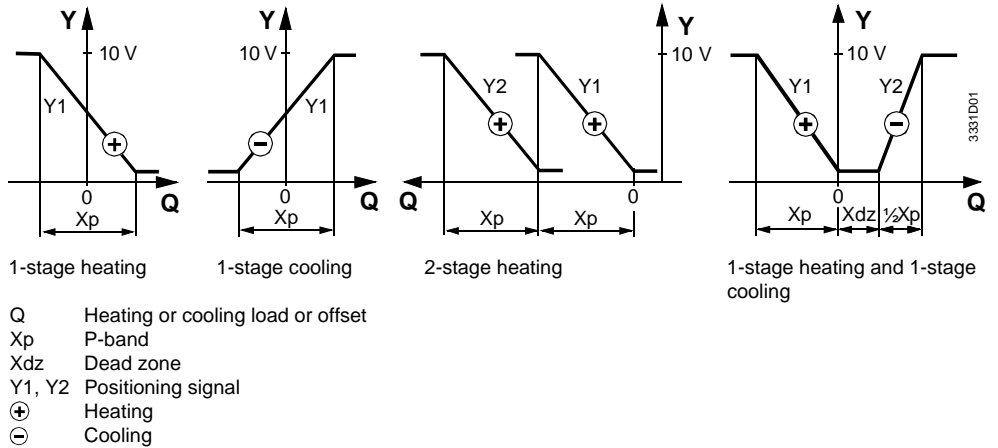

**Outside temperature compensation**

When using an outside sensor, the current setpoint will be shifted depending on the outside temperature. A choice of 2 ranges is available: LOW or HIGH. Within the selected range, compensation is based on fixed values. Depending on the operating action, compensation operates as follows:

**Winter compensation**

Winter compensation (operating action **Heating**):

If the outside temperature falls from 5 °C to 0 °C, the setpoint will be continuously raised by 2 K (LOW) or 4 K (HIGH). Below an outside temperature of 0 °C, the temperature increase will be kept constant

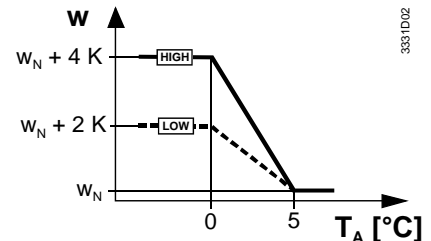

**Summer compensation**

Summer compensation (operating action **Cooling**):

If the outside temperature rises from 22 °C to 35 °C, the setpoint will be continuously raised by 5 K (LOW) or 10 K (HIGH). Above an outside temperature of 35 °C, the temperature increase will be kept constant

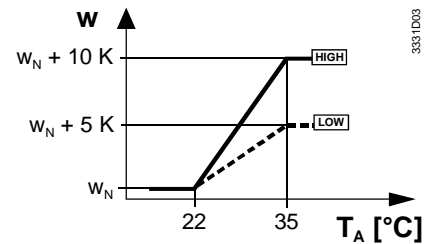

T<sub>A</sub> Outside temperature  
 w Current setpoint  
 w<sub>N</sub> Nominal setpoint

**Minimum limitation of the supply air temperature**

In room or extract air temperature control systems, minimum limitation of the supply air temperature can be provided. In this case, the RLM162 is used as a limiter which delivers its control signal of DC 0...10 V to terminal Z9 of the room or extract air temperature controller (RLA162 or RLM162). If there are significant heat gains in the reference

room, minimum limitation prevents the supply air temperature from falling below a certain level.

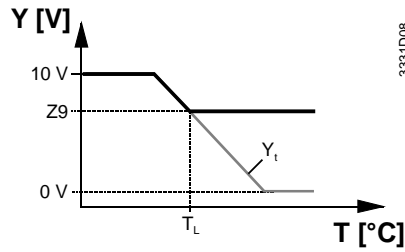

**1-stage heating**  
Minimum limitation of the controlled temperature

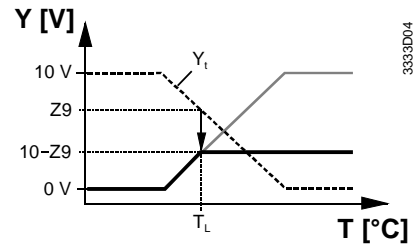

**1-stage cooling**  
Minimum limitation of the controlled temperature through maximum limitation of the output for cooling

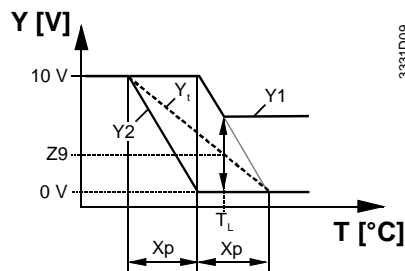

**2-stage heating**  
Minimum limitation, acting on Y1 and Y2

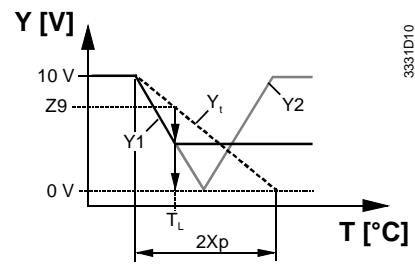

**1-stage heating and 1-stage cooling**  
Minimum limitation, acting on Y1 and Y2

T Controlled temperature  
 $T_L$  Limit temperature  
 $X_p$  P-band  
 $Y$  Positioning signal of controller  
 $Y_t$  Simulated positioning signal  
 $Z_9$  Signal delivered by the limiter to terminal Z9

**Remote setpoint adjustment**

Where the controller is mounted in an inaccessible location, a remote setpoint adjuster BSG21.1 can be connected to the RLM162 (terminals R1–M), thus permitting remote setpoint adjustments. There are 2 choices, but only one of them can be used by one controller.

<i>Position of the setpoint setting slider</i>	<i>Adjustment</i>
The controller's setpoint setting slider must be set to <b>EXT</b>	The setpoint can be adjusted
The controller's setpoint setting slider must <b>not</b> be set to EXT	The setpoint adjusted with the slider can be readjusted in the range -5 K...+5 K.

**Setpoint changeover (D1)**

Changeover of the nominal setpoint can be accomplished by closing an external potential-free contact across terminals D1–M, aimed at saving energy.

- Operating action **Heating**: the nominal setpoint will be **lowered**
- Operating action **Cooling**: the nominal setpoint will be **raised**

Examples:

- Night setback; changeover provided by a time switch
- Setback during non-occupancy times; changeover provided by a presence detector

A slider is provided to set the temperature by which the nominal setpoint shall be lowered or raised. It is not accessible by the user.

**Heating/cooling changeover (D2)**

Changeover of the output signal Y1 can be accomplished by closing an external potential-free contact across terminals D2–M. Digital input D2 is only active in the operating mode **Heating only** (switches 1 and 2 =  ).

**Example**

2-pipe changeover system (using the same valve for heating during winter and cooling during summer), changeover made manually or via thermostat on the heating/cooling medium flow.

If required when switching from heating to cooling mode, closing an external potential-free contact across terminals D1–M can raise the normal air setpoint (see “Setpoint changeover D1” above).

**Switching contact**

The switching output (terminals Q13–Q14) enables a plant element to be switched depending on the heating or cooling load. A potentiometer is provided, which sets the fixed switching points of the relay. 2 choices are available:

- On at 5 % / Off at 0 %, **or**
- On at 90 % / Off at 60 %

**1-stage heating or cooling**

If the heating or cooling load leaves the correcting span of output Y1, the controller calculates an internal control signal Y2. That signal is not fed to output Y2 however, but directly to the switching contact. When the internal control signal has reached 90 % of its span, the contact makes; at 60 %, it breaks.

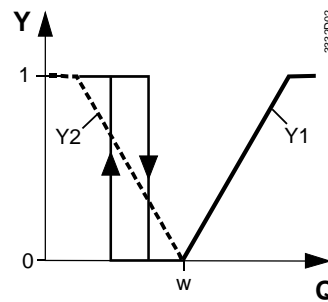
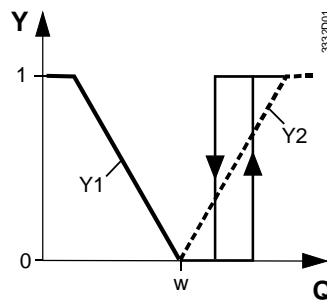

1-stage heating

1-stage cooling

Q Heating or cooling load  
 w Setpoint  
 Y Manipulated variable at output Y1 or Y2

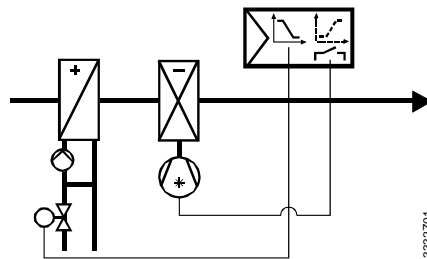

**Example 1:**

Modulating heating valve control with control signal Y1 and switching cooling equipment via Q13–Q14.

**2-stage heating or heating and cooling**

The switching contact is controlled exclusively by control signal Y1. If the heating load exceeds 90 % of the correcting span of Y1, the contact makes; at 60 %, it breaks.

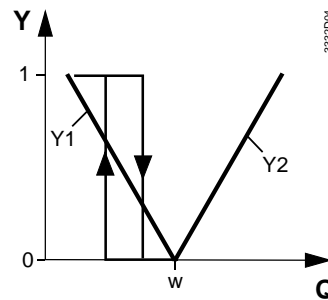
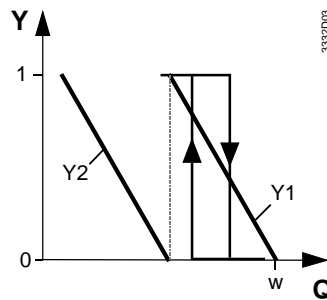

2-stage heating

1-stage heating and 1-stage cooling

Q Heating or cooling load  
 w Setpoint  
 Y Manipulated variable at output Y1 or Y2

**Example**

Modulating heating valve control with control signal Y1 and switching of an electric air heater battery via Q13–Q14

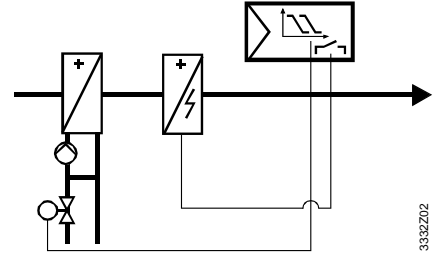

3332Z02

**Example**

Modulating heating valve control with control signal Y1 and load-dependent switching of the AHU coil pump via Q13–Q14.

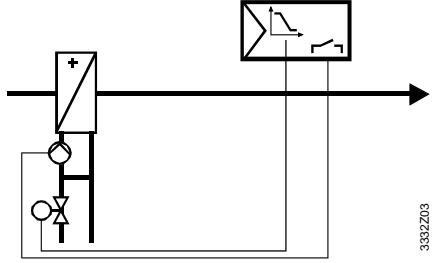

3332Z03

**Test mode**

In test mode, the control is switched off. The setpoint setting slider acts as a positioning unit to manually drive the actuating device (or both actuating devices) to any position required. The positioning range in test mode is configured to match the selected operating mode. The test mode is indicated by an LED.

**Mechanical design**

The controller consists of housing and cover, which carries all operating elements, a mounting flange and a flexible probe.

The housing is made of plastic and accommodates the controller electronics and all operating elements, which are accessible only after removing the cover. The front carries the setpoint setting slider and an LED for indicating operation:

- LED lit: normal operation
- LED flashes: test mode

The following operating elements are provided under the cover:

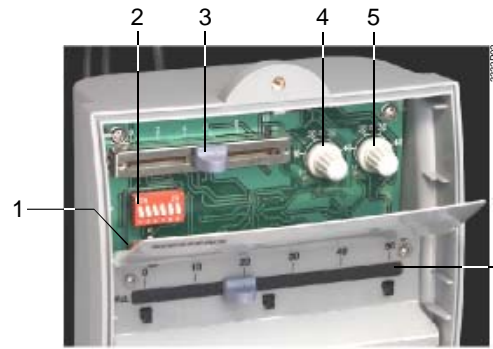

- 1 LED
- 2 Block of DIP switches
- 3 Setting slider for the setpoint increase or decrease
- 4 Setting potentiometer for the relay Q13–Q14
- 5 Setting potentiometer for the P-band
- 6 Setting slider for the main setpoint value

All functions are selected via the DIP switch block which comprises 6 switches:

Function	1	2	3	4	5	6	Action
Operating mode	<input checked="" type="checkbox"/>	<input checked="" type="checkbox"/>	<input type="checkbox"/>	<input type="checkbox"/>	<input type="checkbox"/>	<input type="checkbox"/>	Heating and cooling in sequence
	<input type="checkbox"/>	<input checked="" type="checkbox"/>	<input type="checkbox"/>	<input type="checkbox"/>	<input type="checkbox"/>	<input type="checkbox"/>	2-stage heating
	<input checked="" type="checkbox"/>	<input type="checkbox"/>	<input type="checkbox"/>	<input type="checkbox"/>	<input type="checkbox"/>	<input type="checkbox"/>	1-stage cooling
	<input type="checkbox"/>	<input checked="" type="checkbox"/>	<input type="checkbox"/>	<input type="checkbox"/>	<input type="checkbox"/>	<input type="checkbox"/>	1-stage heating
Control mode	<input type="checkbox"/>	<input type="checkbox"/>	<input checked="" type="checkbox"/>	<input checked="" type="checkbox"/>	<input type="checkbox"/>	<input type="checkbox"/>	P
	<input type="checkbox"/>	<input type="checkbox"/>	<input type="checkbox"/>	<input checked="" type="checkbox"/>	<input checked="" type="checkbox"/>	<input type="checkbox"/>	PI, integral action time = 600 s (SLOW)
	<input type="checkbox"/>	<input type="checkbox"/>	<input type="checkbox"/>	<input checked="" type="checkbox"/>	<input type="checkbox"/>	<input type="checkbox"/>	PI, integral action time = 120 s (FAST)
	<input type="checkbox"/>	<input type="checkbox"/>	<input type="checkbox"/>	<input checked="" type="checkbox"/>	<input checked="" type="checkbox"/>	<input type="checkbox"/>	PI, integral action time = 180 s (MEDIUM)

Function	1	2	3	4	5	6	Action
Test mode					<input checked="" type="checkbox"/>		Test mode
					<input checked="" type="checkbox"/>		Normal operation
Outside temperature compensation						<input checked="" type="checkbox"/>	HIGH
						<input checked="" type="checkbox"/>	LOW

## Engineering notes

In the event of a power failure, the actuating device will automatically close or be driven into the neutral position.

The controller is supplied complete with Mounting and Installation Instruction.

## Mounting notes

The flange is used for mounting the controller onto air ducts.

Ensure that the local safety regulations are complied with.

Suitable mounting locations, depending on the type of control:

- Extract air temperature control:  
Directly after the air extract from the room or in the common duct if there are several air extracts. Always upstream of the extract air fan
- Supply air temperature control and minimum limitation:  
Downstream from the supply air fan if the fan is located downstream from the last air handling element. Otherwise, downstream from the last air handling element at a distance of 0.5 m

The air duct temperature is acquired with a flexible sensing element of 400 mm length.

The flexible sensing element should be laid across the air duct, but should not get in contact with the duct wall. To mount the controller, fit the mounting flange first. Then, the housing is to be snapped on.

## Commissioning notes

To check the control wiring, the controller can be switched into test mode so that the response of the actuating device can be checked.

In case of instability of the control loop, the P-band is to be increased, and with PI-control, the integral action time selection. If the response of the system is too slow, these values are to be reduced.

## Technical data

<b>Power supply</b>	Operating voltage	AC 24 V $\pm$ 20 %
	Frequency	50 / 60 Hz
	Power consumption	max. 2 VA
<b>Functional data</b>	Setting range nominal setpoint	0...50 °C
	Setting range setpoint changeover	0...10 K
	P-band	1...50 K
	Integral action time with PI control	selectable (600 / 180 / 120 s)
	Dead zone with heating and cooling in sequence	1.5 K
	Control outputs Y1, Y2	
	Voltage	DC 0...10 V, continuous
	Current	max. 1 mA
	Switching output (Q13–Q14)	
	Voltage	AC 24...230 V
Current	max. 2 A	

Max. cable length copper cable 1.5 mm <sup>2</sup>	
For signal input B9	80 m
For switching inputs D1, D2	80 m
Contact sensing (inputs D1–M, D2–M)	DC 6...15 V, 3...6 mA

**Environmental conditions**

Operation	
Climatic conditions	to IEC 721-3-3, class 3K5
Temperature	0...+50 °C
Humidity	<95 % r.h.
Transport	
Climatic conditions	to IEC 721-3-2, class 2K3
Temperature	-25...+70 °C
Humidity	<95 % r.h.
Mechanical conditions	class 2M2

**Norms and standards**

<b>CE</b> conformity according to	
EMC directives	89/336/EEC
Low voltage directives	73/23/EEC and 93/68/EEC
Product standards	
Automatic electrical controls for household and similar use	EN 60 730 and EN 60 730-2-9
Electromagnetic compatibility	
Emissions	EN 50 081-1
Immunity	EN 50 082-1
Degree of protection	IP65 EN 60 529
Safety class	II to EN 60 730
Degree of contamination	normal

**General**

Connection terminals for solid wires or stranded wires	2 × 1.5 mm <sup>2</sup> or 1 × 2.5 mm <sup>2</sup>
Weight	0.3 kg

**Connection terminals**

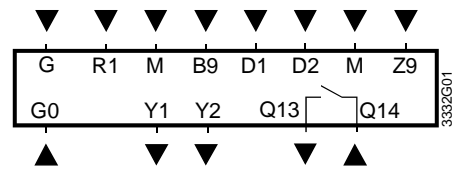

- B9 Outside sensor
- D1 Input for setpoint changeover
- D2 Input for heating/cooling changeover
- G Operating voltage AC 24 V, system potential SP
- G0 Operating voltage AC 24 V, system neutral SN
- M Ground
- R1 Input for remote setpoint adjuster
- Q13 Switching contact
- Q14 Switching contact
- Y1 Control output DC 0...10 V
- Y2 Control output DC 0...10 V
- Z9 Limitation input DC 0...10 V



Connection diagrams

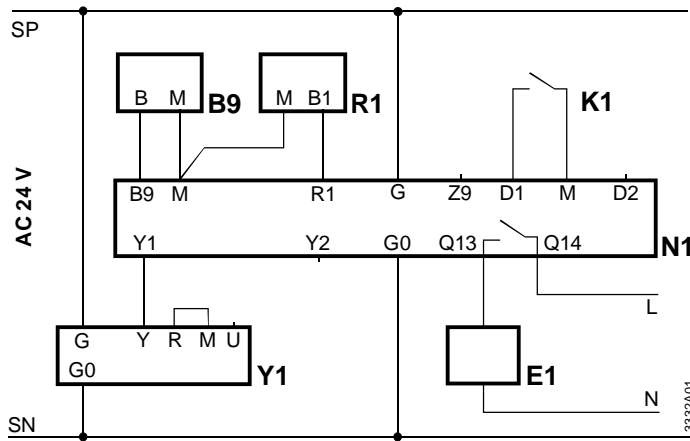

Supply air temperature control with outside temperature compensation, remote setpoint adjuster, setpoint changeover, and control of an auxiliary device

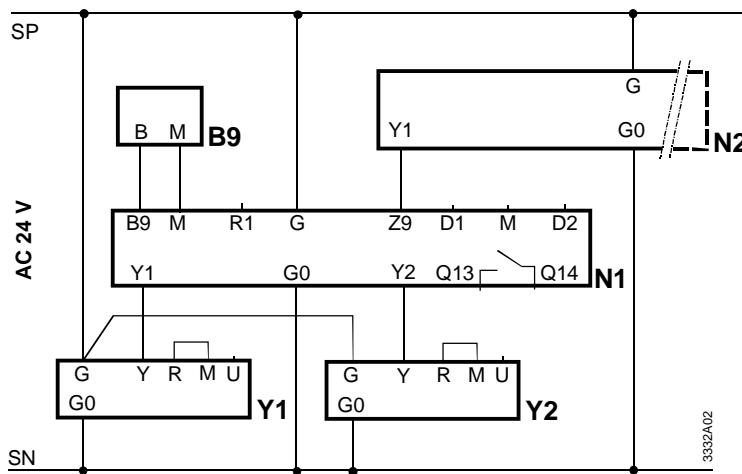

Extract air temperature control with heating and cooling, outside temperature compensation and minimum limitation of the supply air temperature

- B9 Outside sensor QAC22
- E1 Auxiliary device
- K1 External switch (e.g. time switch)
- N1 Air duct temperature controller RLM162 (as an extract air temperature controller)
- N2 Air duct temperature controller RLM162 (as a supply air temperature limiter)
- R1 Remote setpoint adjuster BSG21.1
- Y1 Actuator of heating valve
- Y2 Actuator of cooling valve

Application examples

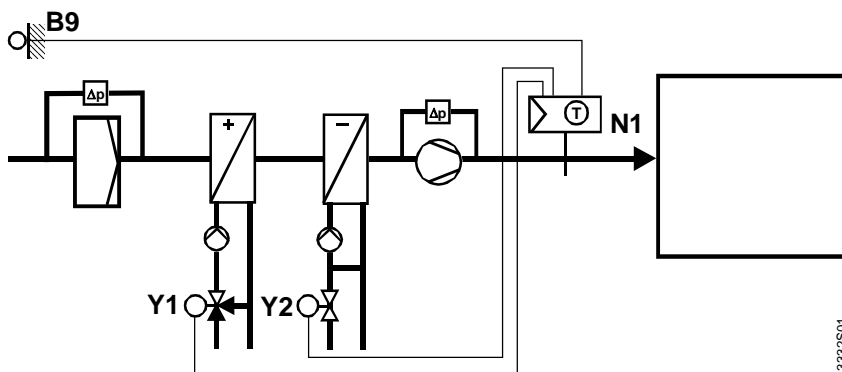

Supply air temperature control through control of the heating or cooling valve in sequence, with outside temperature compensation

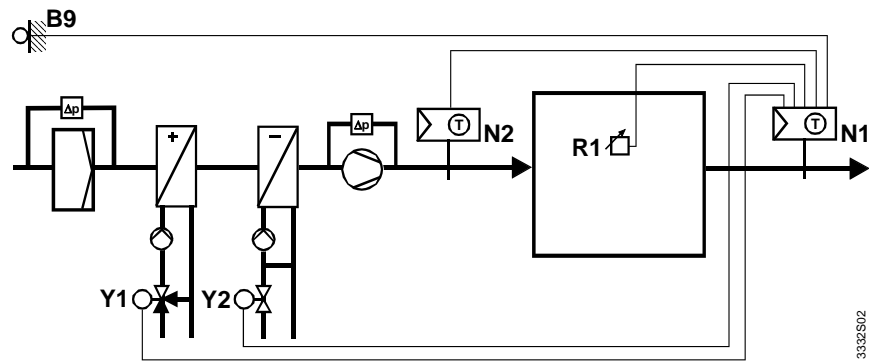

Extract air temperature control through control of the heating and cooling valve in sequence, with outside temperature compensation, remote setpoint adjuster, and limitation of the supply air temperature

- B9 Outside sensor QAC22
- N1 Extract air temperature controller RLM162 (as a controller)
- N2 Supply air temperature controller RLM162 (as a limiter)
- R1 Remote setpoint adjuster BSG21.1
- Y1 Heating valve
- Y2 Cooling valve

## Dimensions

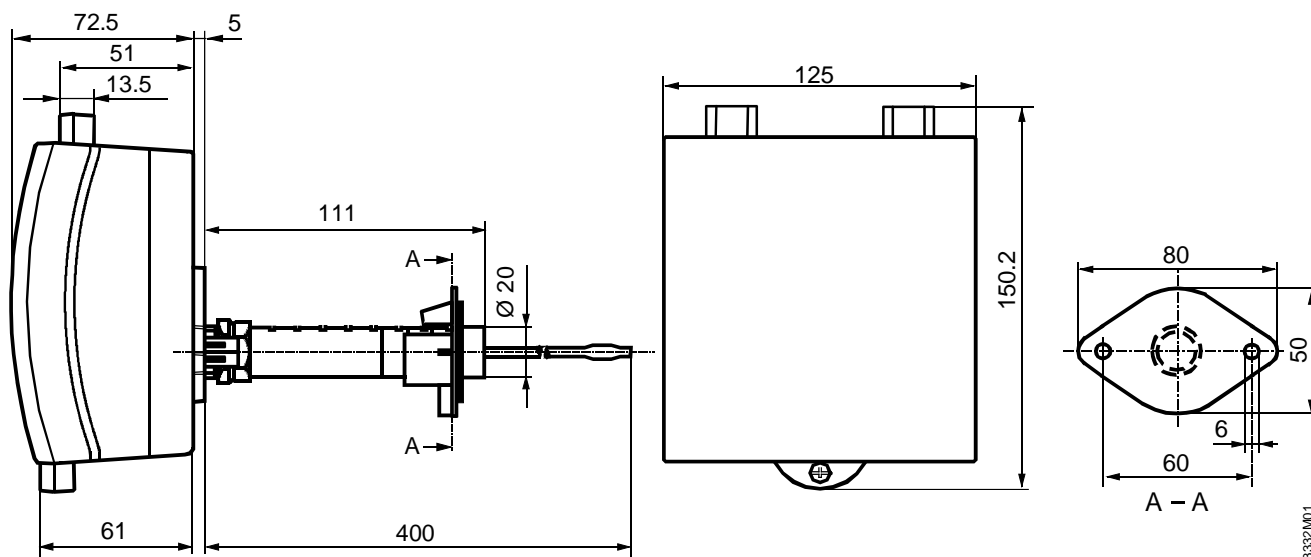

Dimensions in mm