



Product: Q563.2.11

Q563 - 24 hour quartz controlled with battery reserve, 4 pin base, changeover operation.

.2 - Up to two ON and two OFF changeover operations per day.

.11 - Standard Customisation.

The 24 hour programming cycle performs the same sequence of switching operations on each day and can be quickly and easily set using the small manual levers on the dial.

A "day omission" device allows you to select any number of days in the week on which the switching cycle will be disabled.

A general purpose changeover timeswitch suitable for applications where alternating between two circuits is necessary e.g. boilers, compressors.

Product Specification

Programming	24 hour programme with 2 ON and 2 OFF changeover operations per day
Display	24 hour dial
Mounting	Surface mounting
Current Rating	SPDT: 20amp resistive
Supply	230V, 50/60 Hz a.c.
Base Type	4 Pin
Reserve	100 hrs (providing battery has been charged for 300 hrs)
Day Omission	Yes (omits the "ON" operation)
Temp Override Facility (Manual Button)	Advance to "OFF", when program "ON" and will remain "OFF" unit next "ON" operation and vice versa
Cable Size	6.0mm ²
Timing Accuracy	5 mins/year
Power Consumption	0.6W at 230V
Ambient Temperature Range	Designed to operate over a temperature range of 0°C to 50°C continuous
Live Parts Protection	This timer is totally protected by its enclosure
Dirt Protection	Normal domestic dust deposits only
Moisture Protection	Ordinary: has no special protection against moisture
Shock Protection	Class 1 (Product must be earthed)
Dial Calibration	15 min divisions
Setting Accuracy	+/- 3 minutes
Period Between unlike Operations	15 minutes minimum
Period Between like Operations	1 3/4 hours minimum
BEAB Approval	Yes
Dimensions	Height (wall mounted) 136mm, width 105.7mm, projection 82mm, (Total height 146.5mm)

Product: Q563.2.11

Wiring Diagram

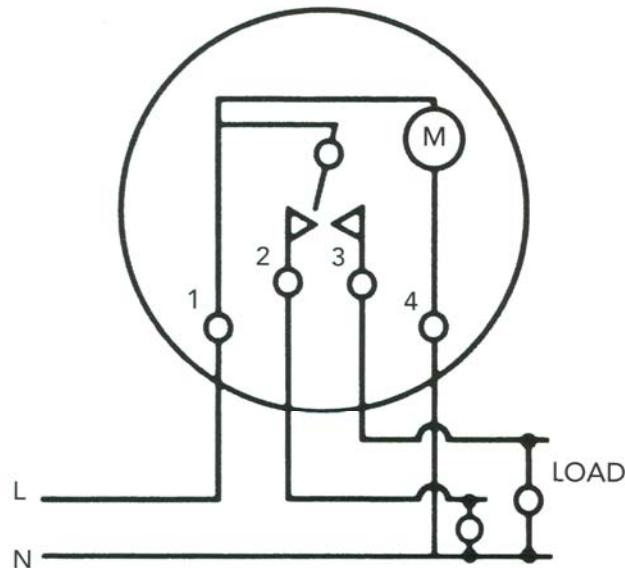

Dimensions

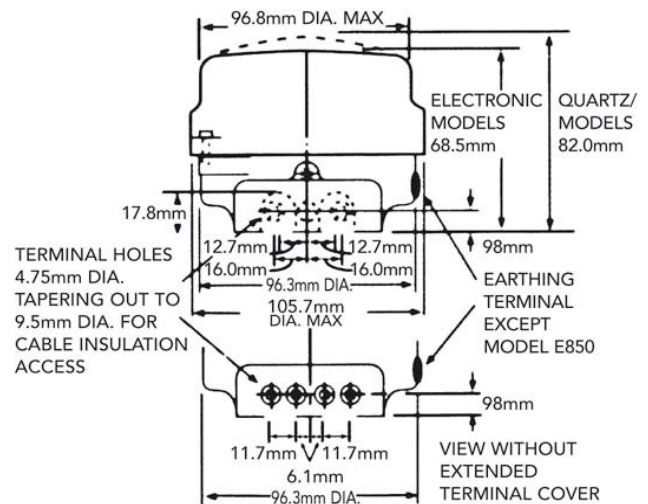
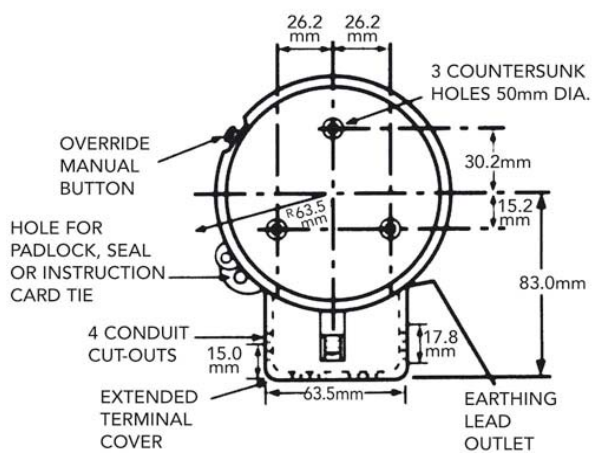

switched on solutions

SANGAMO

Sales Office Direct Line : 0845 006 6206 Fax: 01475 744567 Email: enquiries@sangamo.co.uk

DS/RPTS/0022/A