

Megalife HE

Cistern-fed hot water





Megalife HE

More and more people can see the benefit of replacing their traditional copper cylinder with a modern cistern-fed water heating system that delivers superior reliability and efficiency.

The Megalife HE uses only the best-quality and most advanced vented water heating technology available.

And where necessary for the rigorous levels of performance that our designers stipulate, we've developed pioneering new technologies of our own to bridge the gap.

These advances can come in many forms. An innovative 'coil-in-coil' heat exchanger, which recovers in less than half the time taken by regular heat exchangers; sophisticated Duplex stainless steel cylinder construction for maximum strength and corrosion resistance; high-performance polyurethane foam between the inner vessel and outer casing for the best possible heat insulation; and no sacrificial anodes – for reduced long-term maintenance requirements. Then, to prove our confidence in this advanced new technology, we provide every new system with a 25 year transferable cylinder guarantee including parts and labour with on-site service support.



The traditional cistern-fed or vented storage water heater has a proven track record of reliability and safety. The operating pressure is dictated by the vertical distance between the water level in the cistern tank and the bottom of the heater. The system is intrinsically safe because the open vent that discharges into the cistern tank automatically equalises any excess pressure or vacuum.

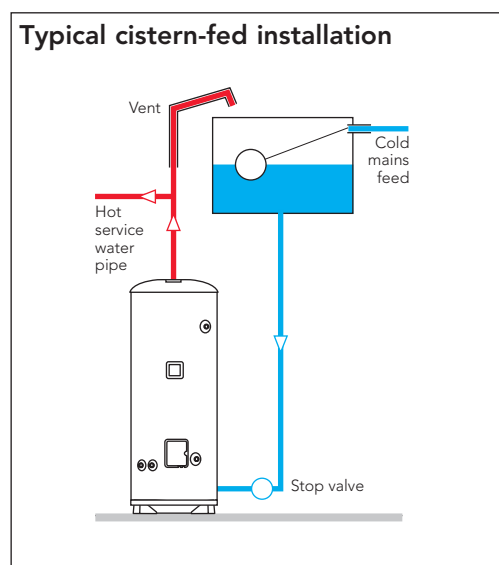

Megalife HE

Duplex stainless steel experience

Heatrae Sadia's expertise with Duplex stainless steel is now extended to vented products with the Megalife HE range. These cylinders can be installed with confidence in the most aggressive water conditions. Corrosion caused by aggressive water is a serious problem in many parts of the country, and can affect traditional cylinders in different ways. It occurs when a number of factors, such as the levels of nitrates, chlorine, manganese or organic matter combine together to increase the water's corrosive potential. All these can ultimately lead to perforation, often after quite short periods of use. Megalife HE resists this corrosion through the use of special grade Duplex stainless steel.

No sacrificial anodes

Sacrificial anodes are used with inferior grades of stainless steel, glass-lined steel and copper to achieve a degree of corrosion resistance. However they require regular replacement which, if not carried out can result in premature cylinder failure. Megalife HE overcomes any need for sacrificial anodes and associated maintenance by using top quality Duplex stainless steel.

Minimal heat loss

To minimise heat loss a 50mm thick void-free layer of high performance polyurethane foam fills the space between the inner vessel and outer casing for maximum insulation efficiency. Megalife HE's carefully moulded one-piece insulation cannot separate in transit to ensure that its effectiveness is maintained, unlike other designs, which rely on the butt jointing of sheet materials. The base is fully insulated and the unit stands on three moulded feet to minimise heat losses to the supporting floor. Immersion heaters and controls are fully integrated – no large external bosses to radiate heat.





All Megalife HE units are designed and manufactured to a very high quality using the latest manufacturing techniques. It boasts numerous innovative features designed to ensure high levels of operating efficiency.

- Transferable 25 year cylinder guarantee with on-site service support.
- Duplex stainless steel construction.
- No anode.
- Fast recovery coil.
- 40 metre (4 bar) maximum working head.
- Alloy sheathed immersion heaters.
- Immersion heater and safety cut-out designed to meet latest EU standards.
- Modern replacement for Cirrus & UDB cylinders.
- Ideal for use in aggressive water areas.

Transferable 25 year guarantee

Megalife HE is guaranteed a long operational life and with no anode to inspect or replace, maintenance costs are reduced. All Megalife HE units are backed by our transferable 25 year cylinder guarantee as part of Heatrae Sadia's 'fit and forget' product programme.

Extending our fit and forget philosophy

Heatrae Sadia has long been synonymous with water heating reliability. Megalife HE now sets a demanding standard for the operational life of vented water heaters – even in the most aggressive water conditions. Backed by nationwide, on-site service support, Megalife HE's transferable 25 year cylinder guarantee giving users absolute peace of mind.

Performance

Fast recovery coil

Every indirect Megalife HE cylinder features a high performance 'coil-in-coil' heat exchanger which will recover in less than half the time taken by a coil that meets the British Standard. This high performance coil provides greater energy efficiency and more baths per hour.

Coil performance		
Capacity	Recovery (mins)	Coil loading (kW)
100 litre	14	15.4
120 litre	14.5	18.3
150 litre	18.5	17.7
170 litre	20	18.7
210 litre	19	24.5

Recovery times are based on raising 70% capacity from 15°C to 60°C using a primary coil temperature of 80°C ±2°C. This data has been obtained using a simulated standard domestic water heating environment.

Which unit to use		
Type of property	Capacity (direct) (litres)	Capacity (indirect) (litres)
Bedsit	100	100
1 bed 1 bath + shower	120 [†] /150 [†]	120
2 bed 1 bath + shower	150 [†] /170 [†]	120
3 bed 1 bath + shower	210 [†]	150
4 bed 1 bath + shower	210 [†]	170
2/4 bed 2 bath + shower	210 [†]	210

Figures are for guidance only and are based on BS 6700 recommendations. [†]Supplied with two immersion heaters. The Heatrae Sadia Specification Advice Team should be contacted to discuss requirements and designs for specific sites. Actual usage requirements should be assessed in selecting the correct cylinder.

Alloy sheathed immersion heaters

Every Megalife HE is supplied with one or more tin-plated alloy 825 sheathed immersion heaters. Immersion heaters are guaranteed for a period of two years.

Immersion heater performance			
Capacity (direct)	Heat up time (mins)		
	Lower (3kW only)	Upper boost & Lower (6kW)	Upper boost (3kW only)
100 litre	97	n/a	n/a
120 litre	116	58	46
150 litre	148	74	65
170 litre	164	82	69
210 litre	203	102	77

Capacity (indirect)	Heat up time (mins)		
	Lower (3kW only)	Upper boost & Lower (6kW)	Upper boost (3kW only)
100 litre	97	n/a	n/a
120 litre	116	n/a	n/a
150 litre	148	n/a	n/a
170 litre	164	n/a	n/a
210 litre	203	102	77

Full specifications, dimensions and ordering

Specification

Capacities

100, 120, 150, 170 and 210 litre unit available in direct and indirect versions.

Rating

3kW, 6kW @ 240V and 2.8kW, 5.6kW @ 230V. Dependent on model.

Outer casing

White textured, plastic-coated corrosion-proofed steel.

Insulation

CFC/HCFC-free (ODP zero) fire-retardant, 50mm thick expanded polyurethane.

Water container

Duplex 2304 (1.4362 EN 10088) stainless steel. 40 metres (4 bar) maximum working head.

Heat unit

Tin-plated alloy 825 sheathed. Megalife HE direct 120, 150, 170 and 210 units have two immersion heaters.

Primary coil

22mm diameter stainless steel. 3.5 bar maximum working pressure.

Thermostat

Indirect models – factory-fitted with 10°C to 70°C adjustable cylinder thermostat.

Safety

Thermostats with manually-resettable thermal cut-out.

Anode

Not required.

Approvals

Kiwa approved. CE marked.

Manufactured in the UK in a BS EN ISO 9001:2008 and ISO 14001:2004 registered factory.

Installation

Fixing

Built-in feet for floor-standing.

Plumbing

Inlet/outlet: ¾" BSP male / 22mm compression fittings supplied.

Indirect coil: ¾" BSP male / 22mm compression fittings supplied.

Secondary circulation

½" BSP female (secondary circulation is not recommended for direct electric units being used on off-peak electricity tariffs).

The Megalife HE must be fitted with a vent pipe that rises continuously and is arranged to discharge into the cold water feed cistern. The primary flow from the boiler must be pumped. Gravity circulation will not work due to the special design of the primary heat exchanger.

Electrical

Each immersion heater must be permanently connected to the electrical supply through a double-pole linked switch with a minimum breaking capacity of 13 amp. The indirect thermal controls should be wired into a suitable indirect control system to ensure optimum control of the Megalife HE and boiler.

All electrical work must comply with the latest BS 7671 (IEE Wiring Regulations). Our Specification Advice Team is available to discuss requirements for specific projects, applications and product selection on Tel: 01603 420220.

Guarantee

On-site service support from date of purchase. Cylinder 25 years, immersion heater(s) and electric controls two years provided that:

- It has been correctly installed as per the instructions contained in the instruction manual and all relevant Codes of Practice and Regulations in force at the time of installation.
- It has not been modified in any way, other than by Heatrae Sadia Heating.
- It has not been frost damaged.
- It has only been used for the storage of potable water.
- It has not been tampered with or been subjected to misuse or neglect.
- Within 60 days of installation the user completes and returns the certificate supplied along with the proof of purchase to register the product.

The Megalife HE immersion heater and thermal controls are guaranteed for a period of two years from the date of purchase. Evidence of purchase and date of supply must be submitted. The unit is not guaranteed against damage due to frost. The guarantee is transferable. This guarantee does not affect your statutory rights.

Dimensions

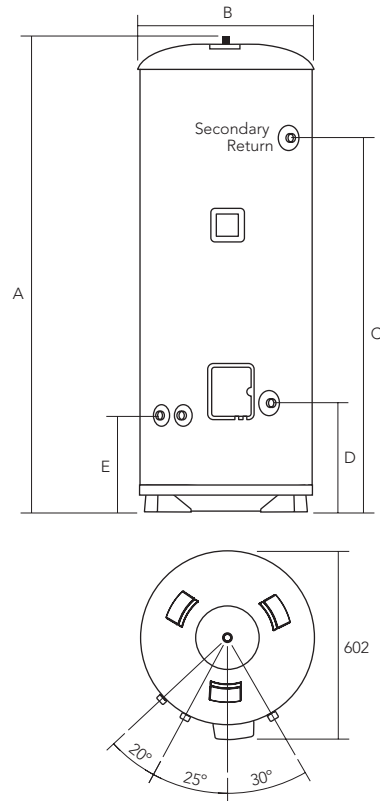

Model	A (mm)	B (mm)	C (mm)	D (mm)	E (mm)	Weight	
						empty (kg)	full (kg)
Megalife HE 100 indirect	813	550	493	354	314	25	125
Megalife HE 120 indirect	935	550	615	354	314	27	147
Megalife HE 150 indirect	1119	550	800	354	314	31	181
Megalife HE 170 indirect	1245	550	925	354	314	34	204
Megalife HE 210 indirect	1503	550	1184	354	314	47	257
Megalife HE 100 direct	813	550	493	306	*	25	124
Megalife HE 120 direct	935	550	615	306	*	26	146
Megalife HE 150 direct	1119	550	800	306	*	29	179
Megalife HE 170 direct	1245	550	925	306	*	31	201
Megalife HE 210 direct	1503	550	1184	306	*	42	252

* Coil not applicable to direct models

Ordering guide

Model	Product code
Megalife HE 100 indirect	95:030:710
Megalife HE 120 indirect	95:030:714
Megalife HE 150 indirect	95:030:711
Megalife HE 170 indirect	95:030:712
Megalife HE 210 indirect	95:030:713
Megalife HE 100 direct	95:030:700
Megalife HE 120 direct	95:030:704
Megalife HE 150 direct	95:030:701
Megalife HE 170 direct	95:030:702
Megalife HE 210 direct	95:030:703



Specification Advice Hotline: 01603 420220 Email: specifier@heatraesadia.com

Megalife Solar

Megalife Solar is a cistern-fed Duplex stainless steel solar thermal vented cylinder designed as a simple upgrade for systems which currently have a traditional copper cylinder.

Megalife Solar has been designed to provide a balance between the dedicated solar heating capacity and the immersion heater or boiler heated capacity. This ensures that the benefit is gained from solar energy and that there will be sufficient hot water on days where there is little solar gain, such as during winter months. This enables the home owner's everyday hot water needs to be met efficiently and gives specifiers the correct choice of products when specifying for Building Regulations* via SAP**.

*Part L (England & Wales), Section 6 (Scotland) and Part F (Northern Ireland)

**Standard Assessment Procedure for Energy Rating of Dwellings



Baxi Solarflo

Our Megalife Solar cylinder is the ideal companion for the Baxi Solarflo system.

- On-roof, in-roof and flat roof solar collector packages available.
- Evacuated tube packages now also available.
- Reduces CO₂ emissions and domestic fuel bills.
- National technical support and after sales service from a single source.
- Produces approximately 55% of a home's domestic hot water needs.





All Megalife Solar units are designed and manufactured to a very high quality using the latest manufacturing techniques. It boasts numerous innovative features designed to ensure high levels of operating efficiency.

- Specially-designed solar coil for maximum solar efficiency.
- Safety and hot water controls.
- Compatible with a wide range of UK solar systems.
- Lower running costs.
- Environmentally friendly – reduced carbon emissions.
- Equally suited for new build or refurbishment projects.
- Thermostat with manually-resettable thermal cut-out. Factory-fitted thermal cut-out for integration into solar circuit.

How does Megalife Solar work?

The solar cylinder is used in conjunction with solar panels (not supplied) which convert energy collected from the sun's rays to heat a water / glycol liquid in its pipe work. This liquid is circulated through a specially-designed solar coil in the base of the cylinder where the liquid transfers its heat to the water stored before being pumped back to the solar panel to be reheated. The design of this coil allows maximum solar gain to be achieved ensuring that the solar system is being used to its full potential.

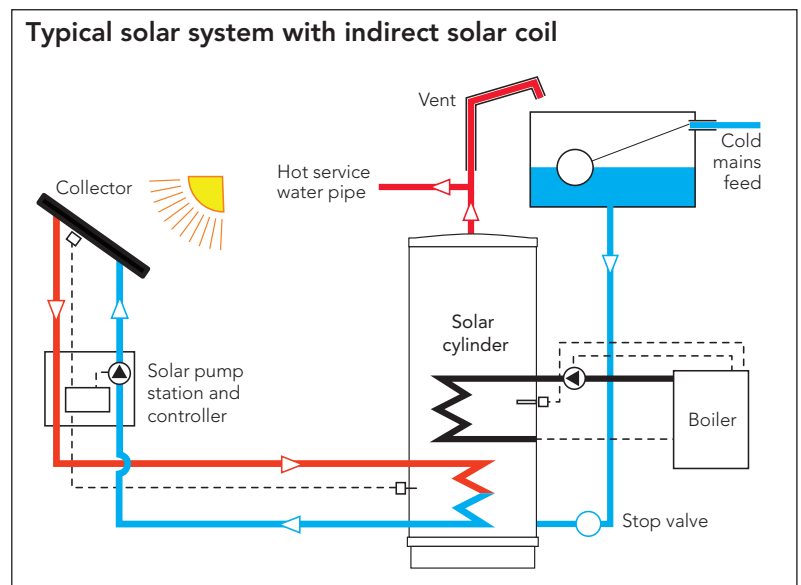

Performance

Which unit to use

The choice of capacity for traditional cylinders is based on the hot water requirements of the dwelling. With solar cylinders the usable hot water will vary due to a number of factors such as siting of solar panels, time of year and weather conditions. For this reason, when choosing a Megalife Solar cylinder you should ensure that sufficient usable hot water will be available during winter months where solar gain is at its lowest.

For example a non-solar dwelling of three inhabitants with a bath and a shower would normally require a 145 litre indirect cylinder.

A portion of the cylinder capacity must be dedicated to solar only, therefore the same dwelling with a solar system would require a 250 litre indirect solar cylinder which would provide 145 litres of hot water during periods where there is little or no solar gain. For guidance please refer to the table below. Some applications may require larger water quantities or higher recovery rates, therefore it is important to calculate the hot water requirement before selecting the cylinder capacity.

Cylinder capacity		
Application	Total solar heated capacity (litre)	Auxiliary top-up hot water capacity (litre)
Megalife Solar 190	70	120
Megalife Solar 210	90	120
Megalife Solar 250	105	145
Megalife Solar 300	125	175

Specification					
Model	Capacity (litre)	Auxiliary element @240V (kW)	Auxiliary coil rating (kW)	Auxiliary coil surface area (m ²)	Solar coil surface area (m ²)
Megalife Solar 190	190	1x 3kW	18	0.61	1.1
Megalife Solar 210	210	1x 3kW	18	0.68	1.1
Megalife Solar 250	250	1x 3kW	18.7	0.73	1.1
Megalife Solar 300	300	1x 3kW	24.5	0.79	1.1

Which unit to use

Indirect

No. of beds	No. of baths / showers	Max. occupancy	On-roof panels	In-roof panels	Tube	Cylinder volume (litre)	Dedicated solar (litre)	On-roof (l/m ²)	In-roof (l/m ²)	Tube (l/m ²)	Max. property size (m ²)	Auxiliary volume (litre)
1	1	2	1	1	20	190	70	38	31	35	60	120
2	1	2	1	1	20	210	90	49	39	45	95	120
3	1	3	2	1	20	250	105	29	46	53	123	145
3	2	4	2	2	20	250	105	29	23	53	123	145
4	1	5	2	2	30	300	125	34	27	42	164	175
4	2	5	3	2	30	300	125	23	27	42	164	175
4/5	2	5	3	2	30	300	125	23	27	42	164	175

On-roof absorber area – 1.84; in-roof absorber area – 2.28; tube absorber area – 1.00. All cylinders are SAP compliant provided the maximum property size is not exceeded. Figures are for guidance only and are based on BS 6700 recommendations.

Full specifications, dimensions and ordering

Specification

Capacities

190, 210, 250 and 300 litre (indirect).

Ratings

Immersion heater(s) 1x 3kW.

Outer casing

White textured, plastic-coated corrosion-protected steel.

Insulation

CFC/HCFC-free (ODP zero) flame-retardant expanded polyurethane (50mm thick). GWP 3.1 (Global Warming Potential).

Water container

Duplex 2304 (1.4362 EN 10088) stainless steel. 40 metres (4 bar) maximum working head.

Heat unit

Tin-plated long-life Superloy 825 alloy sheathed element(s), incorporated into an easily-removable heater plate, should replacement be necessary. Rated 3kW @ 240V.

Primary coil

For auxiliary boiler heating. 22mm diameter stainless steel. Coil-in-coil design for improved performance.

Solar coil

25mm diameter stainless steel. Coil-in-coil design and large surface area for improved performance.

Thermostat

Factory-fitted cylinder thermostat adjusted to 70°C.

Safety

Thermostats with manually-resettable thermal cut-out. Factory-fitted thermal cut-out for integration into a solar circuit.

Anode

Not required.

Approvals

Kiwa approved. CE marked.

Manufactured in the UK in a BS EN ISO 9001:2008 and ISO 14001:2004 registered factory.

Installation

Fixing

Built-in feet for floor mounting.

Plumbing

Inlet / outlet: ¾" BSP male parallel and 22mm compression fittings supplied.

Indirect primary coil: ¾" BSP male parallel and 22mm compression fittings supplied. Solar coil: ¾" BSP male parallel and 22mm compression fittings supplied.

Secondary circulation

½" BSP female connection provided (circulating pump not supplied). Secondary circulation is not recommended for units using off-peak electric elements for auxiliary heating.

Compatible boilers

Gas, electric or oil fired – sealed system or open vent type, fitted with integral control thermostat and thermal cut-out.

Electrical

Each immersion heater must be permanently connected to the electrical supply through a double-pole linked switch with a minimum breaking capacity of 13 amp. The indirect thermal controls should be wired into a suitable indirect control system to ensure optimum control of the Megalife Solar and auxiliary boiler. The solar coil must be connected to a fully pumped solar primary system that should be controlled by a suitable solar controller and hydraulic set.

The solar controller cylinder temperature sensor must be inserted in the pocket supplied on the heater. The solar thermal cut-out (factory-fitted) should be wired in series with the solar controls (not supplied).

All electrical work must comply with the latest BS 7671 (IEE Wiring Regulations).

Our Specification Advice Team is available to discuss requirements for specific projects, applications and product selection on Tel: 01603 420220.

Guarantee

Megalife Solar Duplex stainless steel vessels carry a 25-year transferable guarantee with on-site service support from date of purchase. Five years on expansion vessel. Two years on all other components. Refer to page 7 for more information.

Dimensions

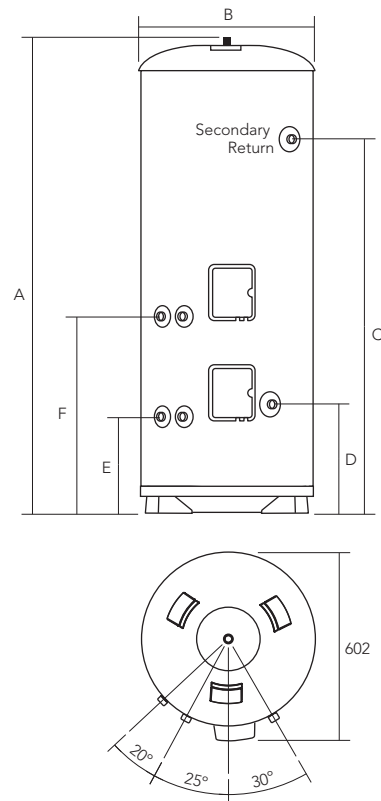

Model	A	B	C	D	E	F	Weight	
	(mm)	(mm)	(mm)	(mm)	(mm)	(mm)	empty (kg)	full (kg)
Megalife Solar 190	1401	550	1019	412	370	732	45.5	235.5
Megalife Solar 210	1502	550	1184	412	370	892	47.5	257.5
Megalife Solar 250	1760	550	1391	412	370	1140	56.5	306.5
Megalife Solar 300	2067	550	1715	412	370	1438	66.5	366.5

Ordering guide

Model	Product code
Megalife Solar 190	95:030:724
Megalife Solar 210	95:030:725
Megalife Solar 250	95:030:726
Megalife Solar 300	95:030:727



Contact

Specification Advice Hotline

T: 01603 420220 F: 01603 420229

E: specifier@heatraesadia.com

After Sales Service

T: 0844 871 1535 F: 0844 871 1528

E: heatraesadiaservice@heateam.co.uk

Web www.heatraesadia.com

heateam

heateam is Heatrae Sadia's very own service division. With us on your side, you can be sure that your customers are in the very best hands. Totally committed to quality and safety, heateam is open 7 days a week, for 363 days a year, and offers:

- **Dedicated Trade Advice Line** – our helpful and qualified specialists are always on hand to help you with even the most complex technical query.
- **Installer Priority Call-Outs** – our 280 strong team of specifically trained expert heating engineers covers the UK, no one is better qualified to look after Heatrae Sadia's products for the duration of the guarantee.
- **Fully Stocked Vans** – a nationwide fleet of vans, fully stocked with spare parts – meaning we can repair our appliances on the first visit in 95% of call-outs.
- **Exclusive Service Plans** – heateam also offer Heatrae Sadia's customers a range of exclusive annual service plans.

Opening Times: Monday-Friday 8am-6pm, weekends and Bank Holidays* 8.30am-2pm.

*excluding Christmas Day and New Year's Day.

Simply call **0844 8711535** or visit our website at www.heateam.co.uk



Heatrae Sadia Heating Hurricane Way Norwich Norfolk NR6 6EA

Heatrae Sadia Heating may introduce modifications to their products from time to time. Consequently, the details given in this brochure are subject to alteration without notice.

95 900 883 Issue 4 © Heatrae Sadia Heating 2011

PART OF BDR THERMEA

Brochures for all of our products are available free of charge. Please call our literature hotline on 01603 420127.

MEGAFLO ECO

Megaflo eco cylinder range

DOMESTIC HEATING AND HOT WATER

Aerheat
Amptec
Electric Solar
Electromax
Electromax Solar
Immersion Heaters
Megalife HE
Megalife Solar
Multipoint Instantaneous
Showers

COMMERCIAL HOT WATER

B3M / C3M
Express
FBM
Handy
Handy Dri / Hair Drier
Hotflo
Multipoint
Multipoint SS
Streamline
UTC 99

DRINKING WATER

SuperChill
Supreme

FSC LOGO



This product is printed on 50% recycled paper. This product is printed using vegetable based inks which are non toxic. Please recycle this product once you have finished with it.