

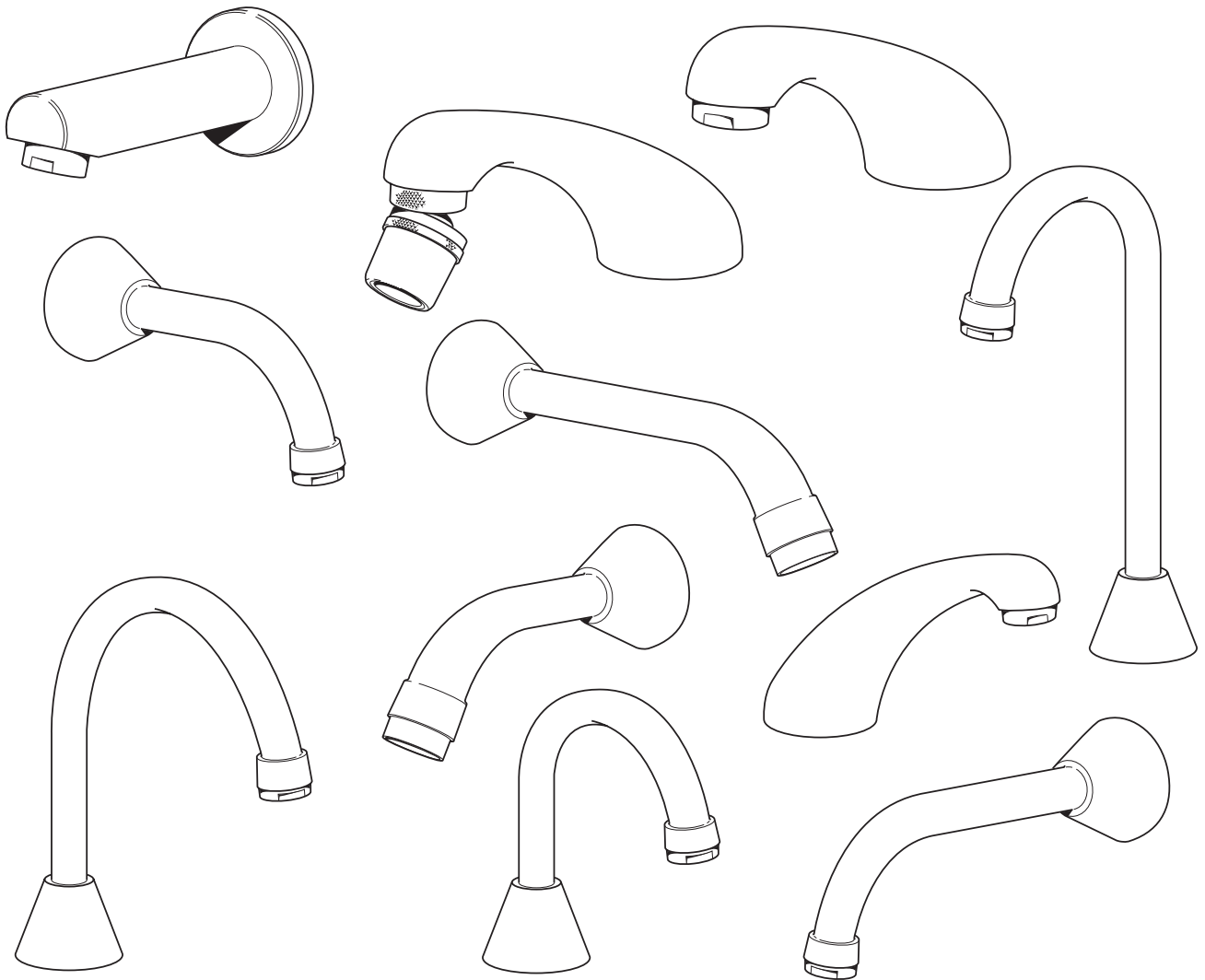

Sense Spout Kits



PRODUCT MANUAL

IMPORTANT

Installer: This Manual is the property of the customer and must be retained with the product for maintenance and operational purposes.

Contents

Description	3
Important Safety Information	3
Specifications	3
Dimensions and Checklist	4
Installation	6
Wall Mounted Bath/Washbasin Spouts	6
Deck Mounted Bath Spouts	6
Deck Mounted Washbasin/Bidet Spouts	7
Maintenance	7
Cleaning	7
Changing the Flow Straightner	7
Spares	7
Straighteners	7
Customer Care	8
Guarantee	8
After Sales Service - how we can help you	8
Spare Parts	8
Customer Care Policy	8
Contact	8

Description

A range of 1/2" washbasin spouts and 3/4" bath spouts for wall or deck mounting, also available a 1/2" bidet spout. Bidet and washbasin spouts are supplied fitted with 5 l/m regulating flow straightners with a optional unregulated flow straightner supplied. Bath spouts are only fitted with unregulated flow straightners.

Important Safety Information

Installation must be carried out in accordance with these instructions, and must be conducted by designated, qualified and competent personnel.

Specifications

Static Pressure - kPa (Bar)	Minimum	10 (0.1)
	Maximum	1000 (10)

Dimensions and Checklist

Tick the appropriate box to familiarise yourself with the spout and to confirm that all the parts illustrated are included.

Note! All dimensions are nominal and in millimetres.

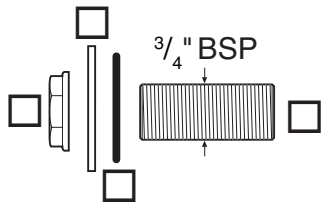
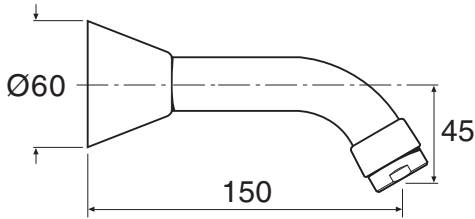

Wall Mounted Bath 150mm
SP T150, Part No. 1503.734

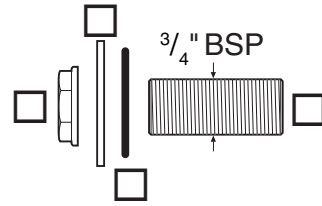
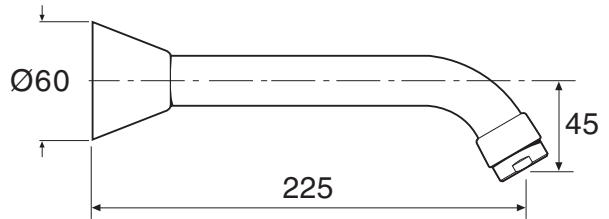

Wall Mounted Bath 225mm
SP T225, Part No. 1503.735

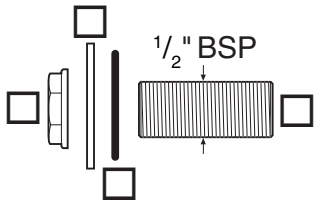
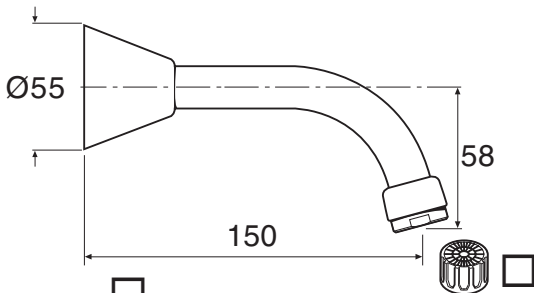

Wall Mounted Washbasin 150mm
SP W150, Part No. 1503.729

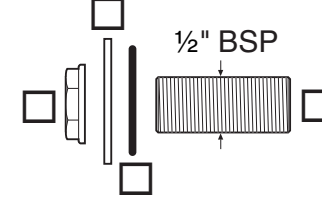
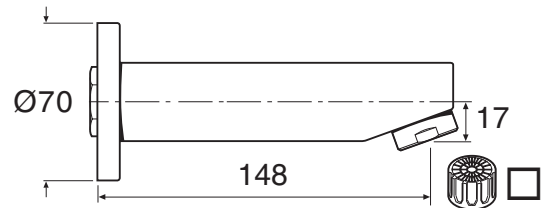

Wall Mounted Washbasin 150Xmm
SP W150X, Part No. 1503.731

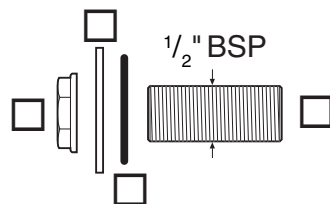
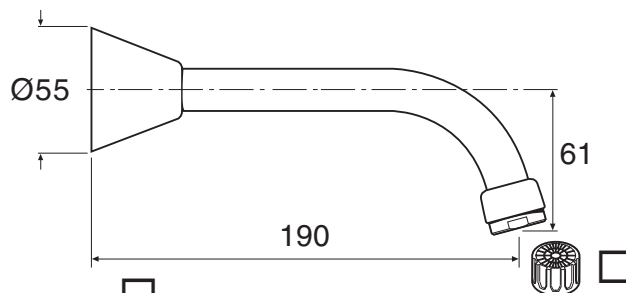

Wall Mounted Washbasin 190mm
SP W190, Part No. 1503.730

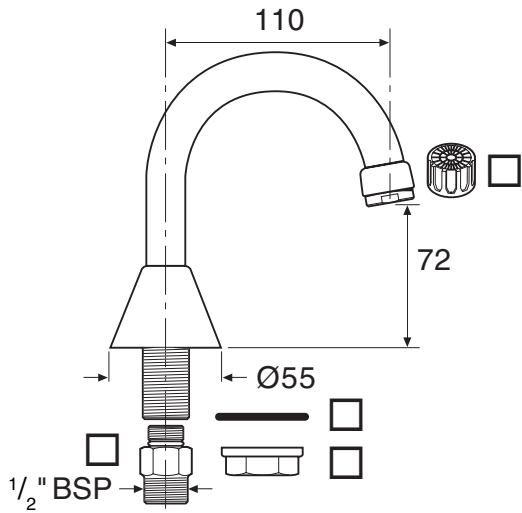

Washbasin Deck 110mm
 SP WD110, Part No. 1503.727

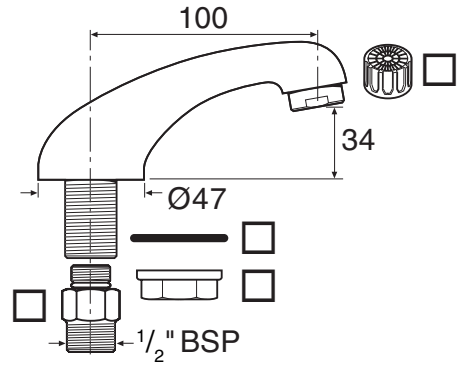

Washbasin Deck 100mm
 SP WD100, Part No. 1503.726

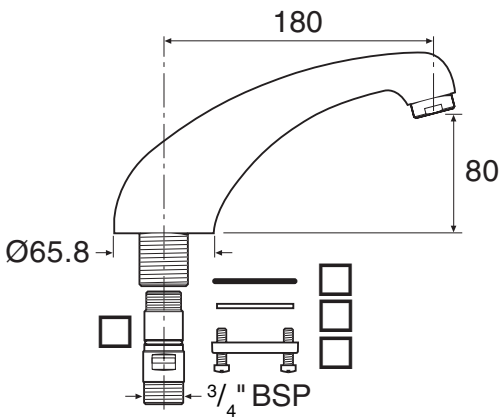

Bath Deck 180mm
 SP TD180, Part No. 1503.732

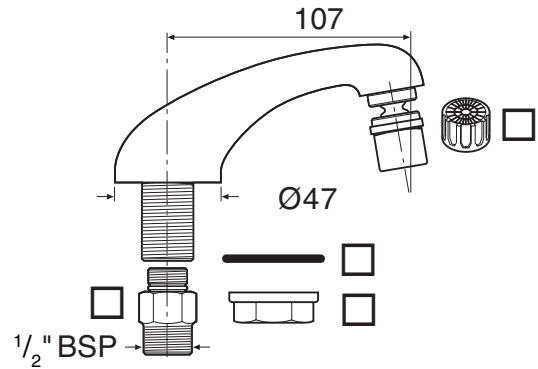

Spout Bidet
 SP Bidet, Part No. 1503.736

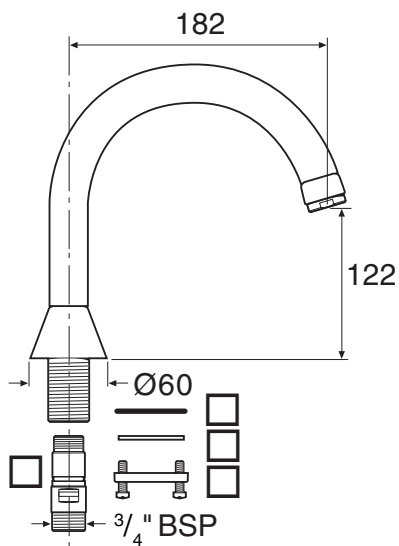

Bath High-neck Deck 200mm
 SP THD200, Part No. 1503.733

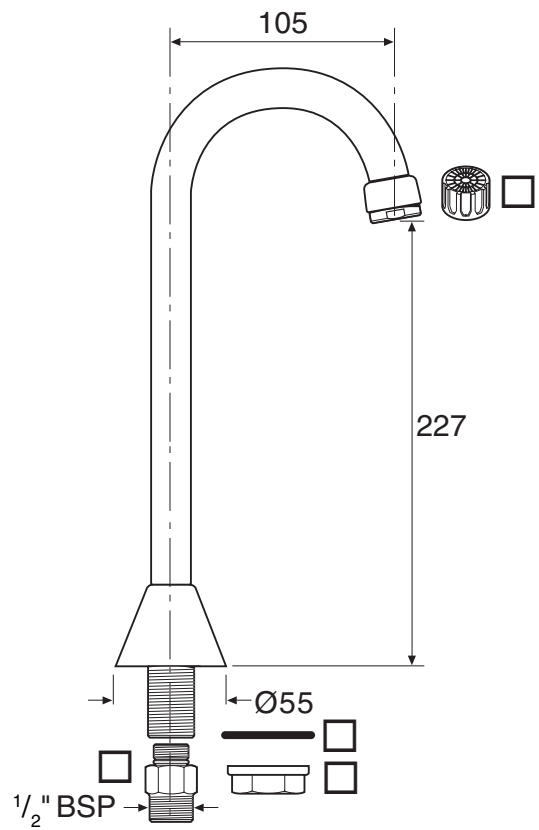

Washbasin High-neck Deck 110mm
 SP WHD110, Part No. 1503.728

Installation

Wall Mounted Bath/Washbasin Spouts

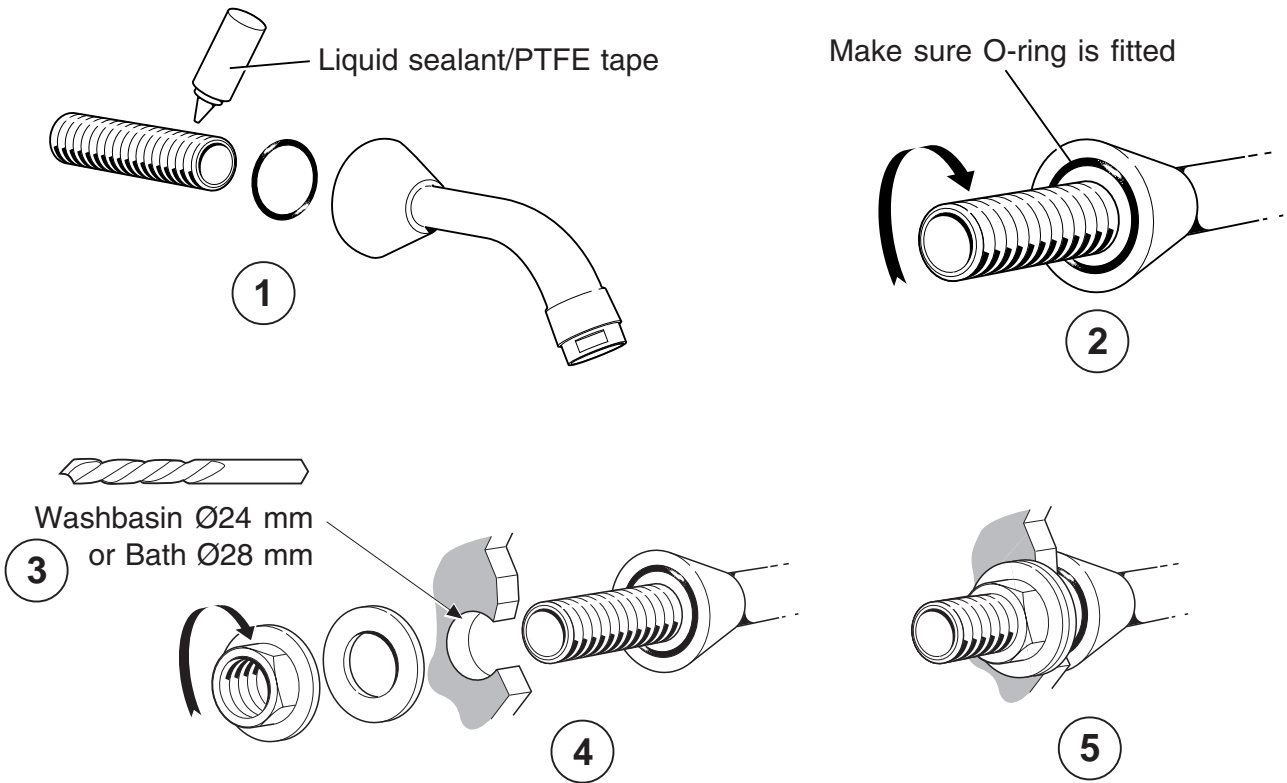

Deck Mounted Bath Spouts

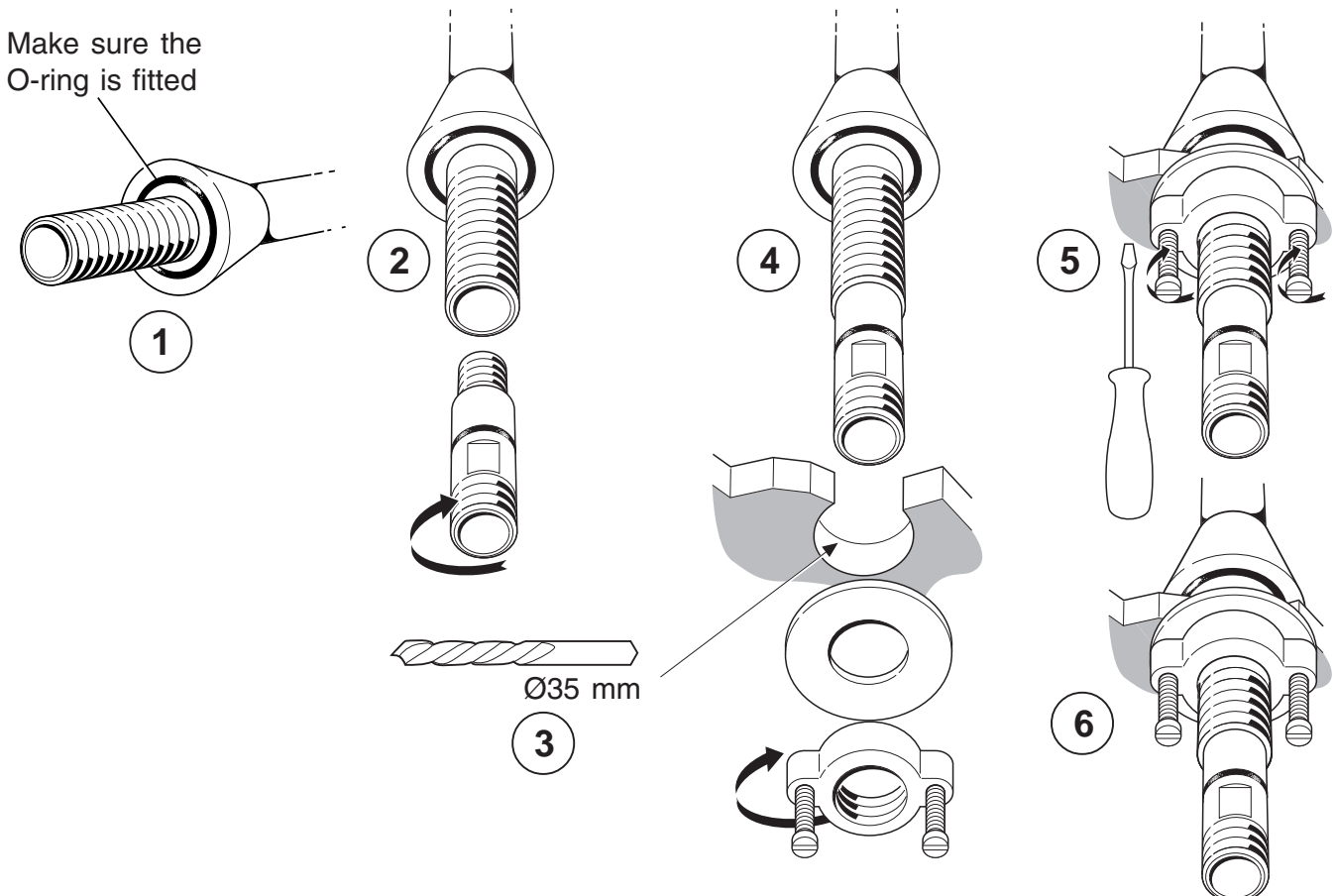

Deck Mounted Washbasin/Bidet Spouts

Make sure the O-ring is fitted

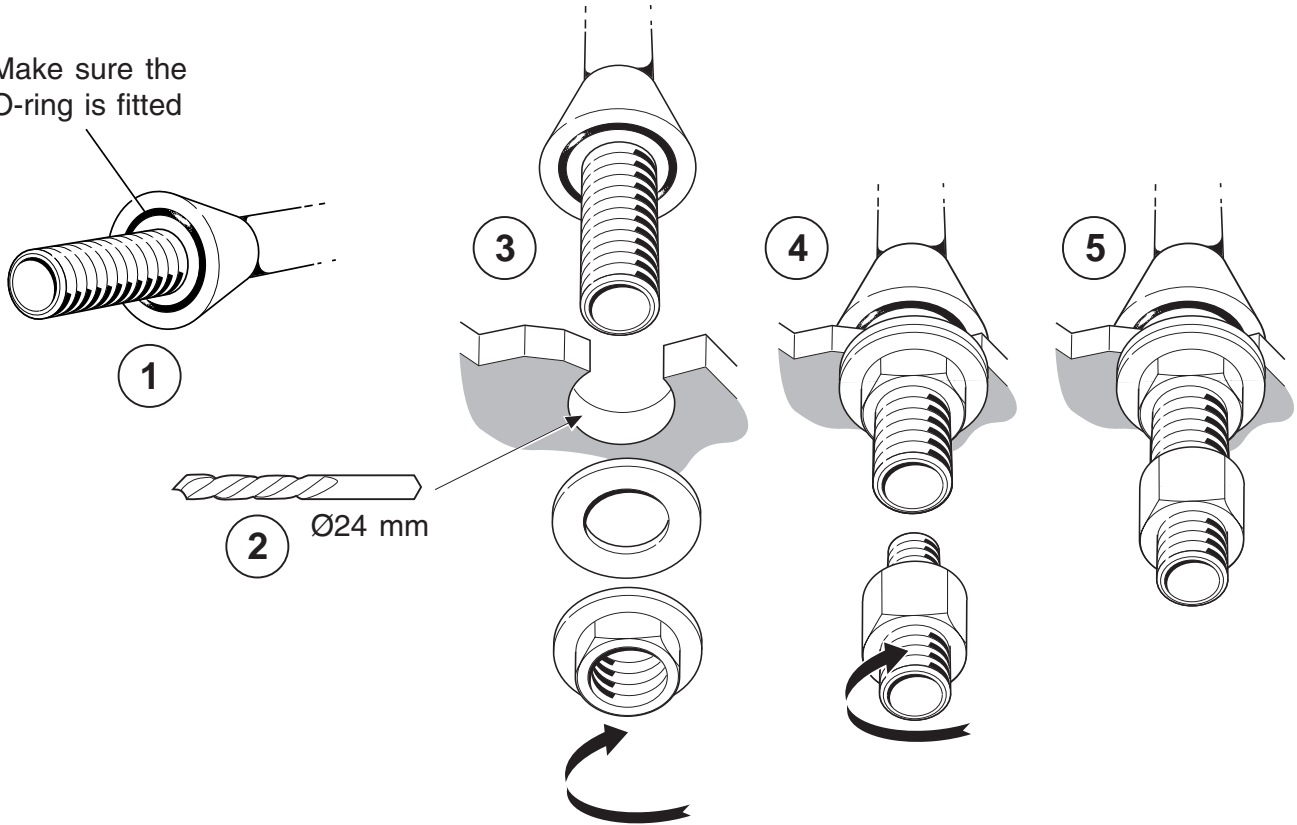

Maintenance

Cleaning

The spouts should **ONLY** be cleaned using a mild washing up detergent or soap solution and wiped dry with a soft cloth.

Changing the Flow Straightener

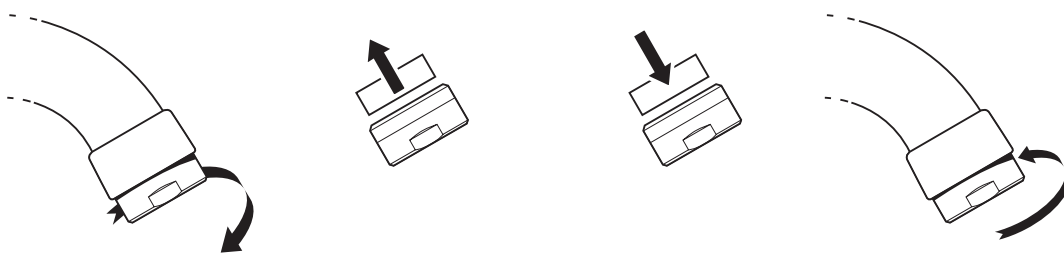

Spares

Straighteners

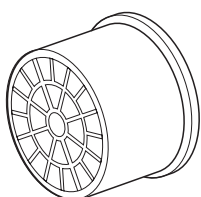

Bath Unregulated
Part No. 463.85

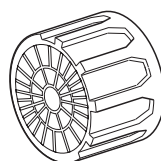

Washbasin Unregulated Washbasin 5l/m Regulating
Part No.463.86

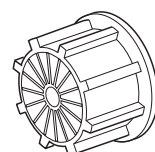

Customer Care

Guarantee

This product is guaranteed against any defect of materials or workmanship for one year from the date of purchase, provided that the product has been installed correctly and used in accordance with the instructions supplied.

Any part found to be defective during the guarantee period will be replaced or repaired - at our option - without charge, provided that the product has been properly used and maintained. Routine cleaning and maintenance should be carried out in accordance with the instructions supplied.

The product should not be modified or repaired except by a person authorised by Rada. Your statutory rights are in no way affected by this guarantee.

After Sales Service - how we can help you

We have a network of fully trained staff ready to provide assistance, should you experience any difficulty operating your Rada equipment.

Spare Parts

All functional parts of Rada products are kept for up to ten years from the date of final manufacture.

If during that period, our stock of a particular part is exhausted we will, as an alternative, provide an equivalent new product or part at a price equating to the cost of repair to the old, bearing in mind the age of the product.

Customer Care Policy

If within a short time of installation the product does not function correctly, first check with the operation and maintenance advice provided in this Manual to see if the difficulty can be overcome.

Failing this, contact your installer to ensure that the product has been installed and commissioned in full accord with our detailed installation instructions.

If this does not resolve the difficulty, please ring your nearest Rada contact who will give every assistance and, if appropriate, arrange for the local Service Engineer or Agent to call on a mutually agreeable date.

Contact

Rada Controls

Cromwell Road,
Cheltenham, England,
GL52 5EP, UK.

Tel.: + 44 (0)1242 221221

Fax.: + 44 (0)1242 221925

Rada is a registered trade mark of
Kohler Mira Limited.

The company reserves the right
to alter product specifications
without notice.

www.radacontrols.com



FM 14648