

Thermostatic

mira
vigour

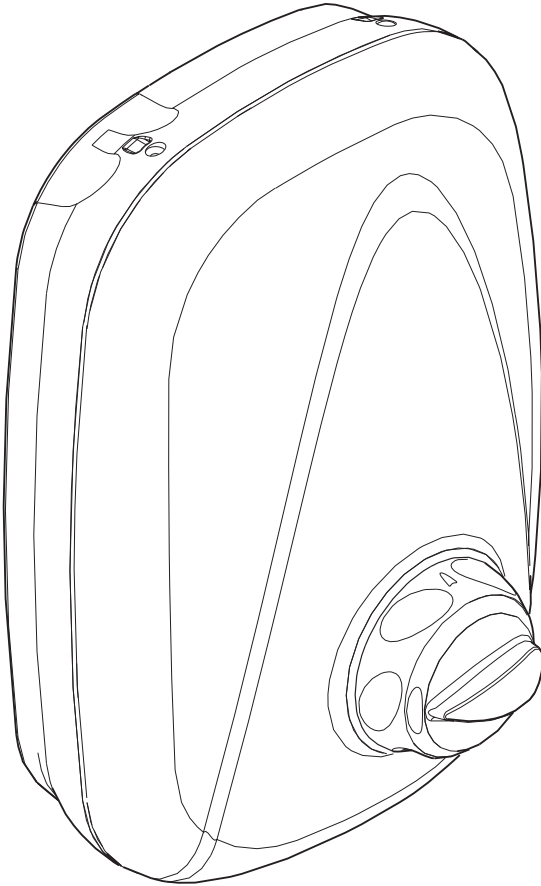

THERMOSTATIC

POWER SHOWER

Installation and User Guide

These instructions are to be left with the user

CONTENTS

Introduction	3
Patents	3
Important Safety Information	3
Warning!	3
Caution!	4
Pack Contents	5
Dimensions	6
Specifications	7
Installation Requirements	8
Installation	9
General.....	9
Electrical.....	9
Plumbing	10
Commissioning	17
Maximum Temperature Setting	18
Disabling the Temperature Override Button	20
Operation	21
Fault Diagnosis	22
Fault Diagnosis - User Maintenance	22
Fault Diagnosis - Installer Maintenance	23
Maintenance	25
Cleaning	25
Handset.....	25
Spare Parts	26
Customer Service	28

INTRODUCTION

The Mira Vigour Thermostatic Power Shower is an all-in-one power shower with an integral mains voltage pump and separate controls for flow and temperature. It features a 15 mm dual entry push-fit manifold which supports various inlet supply configurations. The manifold includes inlet filters and check valves. The thermostatic mixer incorporates a wax capsule sensing unit.

Designed to be surface mounted, the Thermostatic Power Shower comes complete with an adjustable spray handset with three settings, flexible hose, adjustable slider, sliding rail, soap tray and bracket.

Patents

Patents	GB: 2 340 210, 2 392 223, 2 392 224, 2 392 225 USA: 7 240 850
Patent Applications	Euro: 03254070.0

IMPORTANT SAFETY INFORMATION

Warning!

1. Products manufactured by us are safe and without risk provided they are installed, used and maintained in good working order in accordance with our instructions and recommendations.
2. **THIS APPLIANCE MUST BE EARTHED. MAKE SURE SUPPLEMENTARY BONDING COMPLIES WITH THE “REQUIREMENTS FOR ELECTRICAL INSTALLATIONS”.**
In accordance with the current edition of ‘The Plugs and Sockets etc. (Safety) Regulations in force at the time of installation, the Appliance is intended to be permanently connected to the fixed electrical wiring of the mains system.
3. **DO NOT CONNECT THE APPLIANCE TO A MAINS-FED WATER SUPPLY.** Such a connection will damage the Appliance, and is not covered under the manufacturer’s guarantee.
4. The Appliance must not be fitted where it may be exposed to freezing conditions. Make sure that any pipework that could become frozen is properly insulated.
5. **DO NOT** operate the Appliance if it is frozen. Allow the Appliance to thaw before using again.
6. **DO NOT** operate the Appliance if water leaks from the unit, maintenance will be required before the Appliance can be safely used.
7. **DO NOT** allow the Appliance to be run dry.
8. **DO NOT** fit any form of outlet flow control. Only shower fittings recommended by Mira Showers should be used.
9. There are no user serviceable components beneath the cover of the Appliance. Only a competent trades person should remove the cover.

10. Turn off the electrical and water supplies before removing the cover. The electricity must be turned off at the mains and, if applicable, the appropriate circuit fuse removed.
11. Mains connections are exposed when the cover is removed.
12. Moving parts are exposed when the cover is removed.
13. Isolate the electricity and water supplies and refer to “**To contact us**”, on the back page of this guide, if any of the following conditions occur:
 - The cover is not correctly fitted and water has entered the case
 - The case is damaged
 - The Appliance begins to make an odd noise, smell or smoke
 - The Appliance shows signs of a distinct change in performance, indicating a need for maintenance
 - The Appliance is frozen
14. Make sure all electrical connections are tight, to prevent overheating.

Caution!

1. **Read all of these instructions and retain this guide for later use.**
2. Pass on this guide in the event of change of ownership of the installation site.
3. Follow all warnings, cautions and instructions contained in this guide.
4. Follow all warnings, cautions and instructions contained on or inside the appliance.
5. The electrical installation must comply with the “Requirements for Electrical Installations” commonly referred to as the IEE Wiring Regulations, or any particular regulations and practices specified by the local electricity supply company, in force at the time of installation. The installation should be carried out by an electrician or contractor who is registered with, or is a member of an association such as:
 - National Inspection Council for Electrical Installation and Contracting (NICEIC), throughout the UK
 - The Electrical Contractors Association (ECA), England and Wales
 - The Electrical Contractors Association of Scotland (ECAS)
6. The plumbing installation must comply with Water Supply Regulations/Bye-laws (Scotland), Building Regulations or any particular regulations and practices, specified by the local water company or water undertakers. The installation should be carried out by a plumber or contractor who is registered with, or is a member of an association such as:
 - Institute of Plumbing (IOP), throughout the UK
 - National Association of Plumbing, Heating and Mechanical Services Contractors (NAPH & MSC), England and Wales
 - Scottish and Northern Ireland Plumbing Employers’ Federation (SNIPEF), Scotland and Northern Ireland
7. Anyone who may have difficulty understanding or operating the controls of any shower should be attended whilst showering. Particular consideration should be given to the young, the elderly, the infirm, or anyone inexperienced in the correct operation of the controls.
8. When the Appliance has reached the end of its serviceable life, it should be disposed of in a safe manner, in accordance with current local authority recycling, or waste disposal policy.

PACK CONTENTS

Tick the appropriate boxes to familiarise yourself with the part names and to confirm that the parts are included.

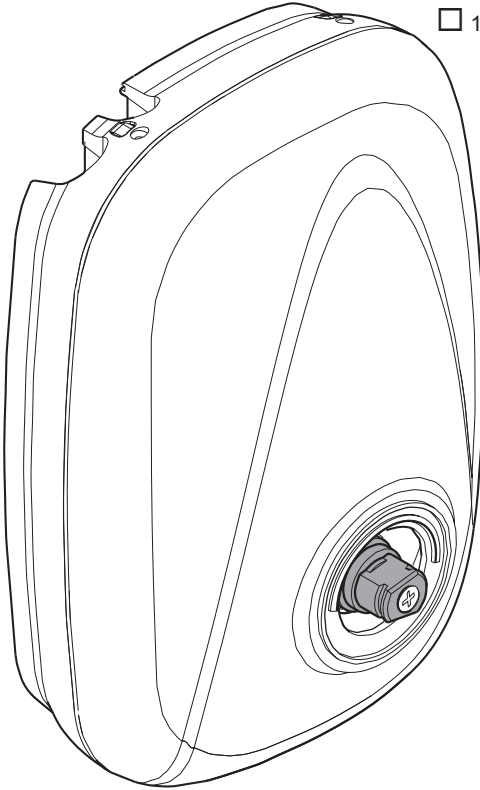

1 x Thermostatic Power Shower

4 x Case Inserts

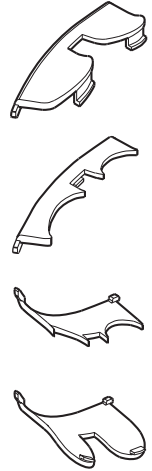

1 x Flow Control Knob

1 x Temperature Indicator Trim

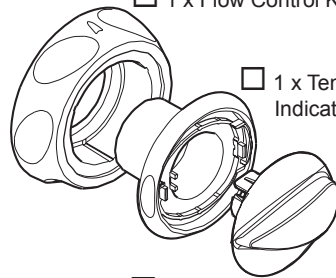

1 x Temperature Control Knob

1 x Installation and User Guide

1 x Guarantee Registration Document

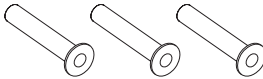

3 x Rubber Wall Plugs



3 x Fixing Screws



3 x Rubber Feet

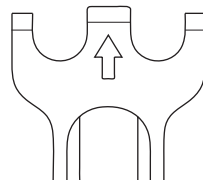

1 x Push-Fit Release Tool

DIMENSIONS

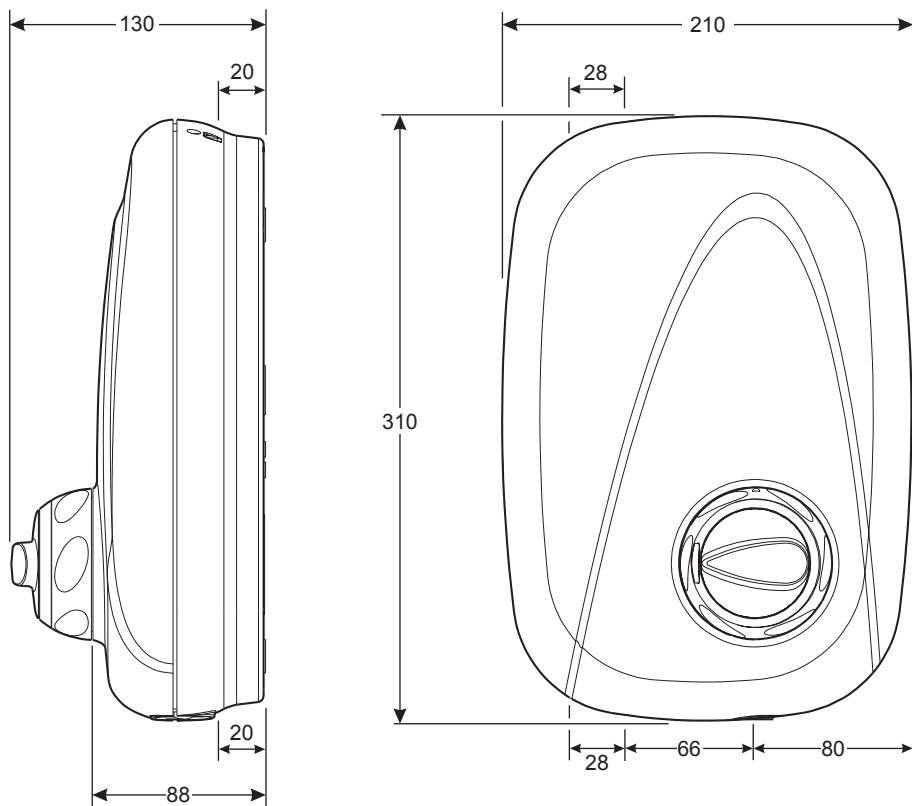

All dimensions are nominal and in millimetres.

SPECIFICATIONS

Electrical

Power supply - 230-240 V at 50 Hz, fused at 3 Amps, via a double pole fused switch (not supplied) with a minimum contact separation of 3 mm for each contact.

Electrical Connections - Terminal block will accept cable up to 2.5 mm². Minimum cable size (cross-sectional area) required under normal installation conditions is 1 mm².

Power Consumption - 150 W maximum.

Plumbing Connections

Inlet Connections - 2 x 15 mm Push-fit manifold.

Outlet Connection - 1/2" BSP male.

Operating Parameters

Cold water temperature - Maximum inlet temperature **30 °C**

Hot water temperature - Maximum inlet temperature **65 °C**

Warning! For safety reasons set the maximum temperature of the stored hot water to between 60 and 65 °C. Such temperatures are considered sufficient to meet all normal requirements and will minimise the deposition of scale in hard water areas.

Temperature Control - The maximum temperature stop is set to 41 °C. Depressing the override button overrides the maximum temperature and allows the showering temperature to be increased by 5 °C to approximately 46 °C.

The showering temperature will be maintained to within 1 °C of selected temperature with a 10 °C change in the hot or cold water supply.

If the cold supply fails the thermostatic mixer will shut down flow of water to seepage levels in approximately 2 seconds. The hot supply **must** be at least 12 °C above the blend temperature for shut down to seepage to occur.

The showering temperature will be maintained to within 1.5 °C of the selected showering temperature when the pressure between inlet and outlet is halved on either the hot or cold side.

Operating pressure

Minimum maintained pressure - **0.1 kPa (0.01 bar)** or **100 mm** head of water.

Maximum maintained pressure - **50 kPa (0.5 bar)**.

Maximum static pressure - **100 kPa (1 bar)** or **10 m** head of water.

Duty Cycle - The Mira Vigour Thermostatic Power Shower pump is now continuously rated. The motor is fitted with a self-resetting thermal trip, designed to operate if motor temperatures become too high due to abnormally high supply voltages.

Noise - The acoustic noise from the pump motor has been reduced with the use of anti-vibration rubber feet and rubber wall plugs. The type of wall the appliance is fixed to will also affect the perceived noise level; solid walls will provide a quieter operation.

Standards

The Mira Vigour Thermostatic Power Shower complies with all relevant directives for CE marking.

INSTALLATION REQUIREMENTS

Gravity Fed system - The shower **MUST** be fed from a cold water cistern and hot water cylinder providing nominally equal pressure.

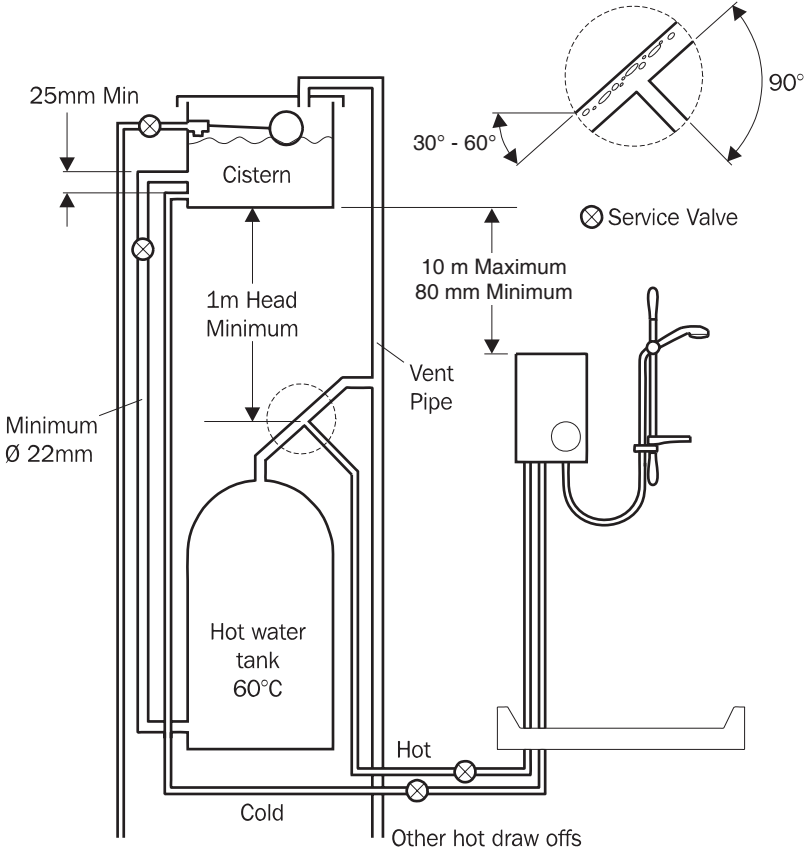

INSTALLATION

General

1. **Do not** take risks with plumbing or electrical equipment.
2. **Do not** install the shower unit in a position where it could become frozen.
3. Isolate electrical and water supplies before proceeding with the installation of the shower unit.
4. The shower unit **must** be fed from a cold water storage cistern and hot water cylinder with equal pressures. The shower unit **must not** be connected to a mains cold water supply, unvented high pressure systems or multipoint/combination gas water heaters.
5. The installation **must** be carried out by a competent installer.
6. Decide on a suitable position for the shower unit (minimum distance of 200 mm from the ceiling to allow for the fitting and removal of the cover). The position of the appliance and the shower fittings must provide a minimum gap of 25 mm between the spillover level of the shower tray/bath and the handset, to prevent back siphonage.
7. Avoid layouts where the hose will be sharply kinked. This may reduce the life of the hose.
8. The shower unit is designed for surface mounting only and **must not** be recessed into any wall or cavity, or tiled up to, as this prevents air circulating to the rear of the unit.

Electrical

1. The shower unit **must be earthed** by connecting the supply cable earth conductor to the earth terminal.
Supplementary bonding: Within the bathroom or shower room, all accessible conductive parts of electrical equipment and extraneous conductive parts that are likely to introduce earth potential, must be electrically bonded to earth using a minimum cable size of 4.0 mm² if the cable is not mechanically protected (2.5 mm² if mechanically protected).
2. Power supply cable **must** have a minimum cross sectional area of 1 mm².
3. Power supply **must** be 230-240 V at 50 Hz. The isolating switch **must** be double pole switched, fused at 3 Amps, with at least a 3 mm contact separation gap to each pole.
4. **Do not** turn the electrical supply on until all plumbing connections have been made and the shower unit has been commissioned as the unit **must not** be operated dry.
5. A 30 mA RCD (residual current device) **must** be fitted. This may be part of the consumer unit or a separate unit.
6. Fuses do not give personal protection against electric shock.

Plumbing

1. A **minimum** storage capacity of cold water of 230 litres (50 gallons) is required to provide adequate showering time. Insufficient storage may result in the pump being run dry.
2. Layout and sizing of pipework **must** be such that nominally equal inlet supply pressures are achieved and the effects on the shower performance of other draw-offs are minimised. Make sure the shower unit is the first draw-off from the water supply.
3. Avoid routing the high level hot feed pipe upward to the same level as the cold tank e.g. into loft space, as air locks may result.
4. **Do not** solder supply pipework connected to the shower unit as heat transfer may damage plastic components.
5. **Do not** use jointing compounds on the shower unit joints, they may cause damage to the mechanism inside.
6. **Do not** insert fingers into the push fit connections.
7. The supply pipe ends **must be free from burrs**, as these will damage the push fit seals.
8. **Do not** use stainless steel piping for inlet pipework.
9. If plated tubing is used for inlet pipework remove the plating from the last 25 mm of the tube to make sure of a good seal.
10. 15 mm polythene plastic pipe suitable for hot water may be used to supply the shower unit, but internal pipe supports **must be** used.
11. Supplies **must be** thoroughly flushed to remove any debris before connecting the shower unit.
12. Fit non-restrictive (free-flowing) isolating valves in the inlet pipework to the appliance. Make sure that you can access the isolating valves easily.

Warning! Do not fix the shower unit to the wall until plumbing and electrical installations have been completed.

1. Decide on a suitable location for the shower unit **avoiding buried cables and pipes**. The unit should be positioned at a height convenient for all the family (at least 200 mm below the ceiling to allow for the fitting and removal of the unit cover).

The handset should spray away from the shower unit, either down the centre line of the bath or across the shower cubicle opening. Make sure when the hose retaining ring is placed on the lowest position on the slide bar, the handset does not fall below the **minimum clearance gap**, between the bath or shower tray spillover level of 25 mm.

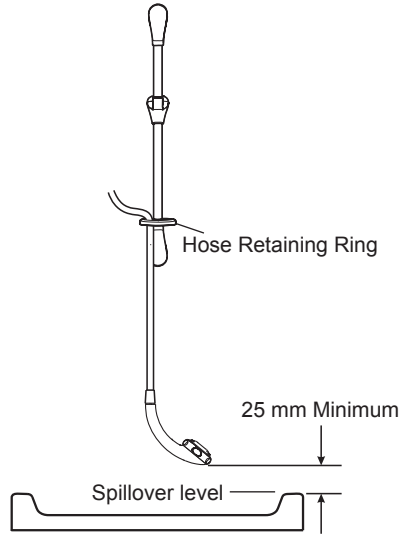

2. Hot and cold inlet supply connections are:

Hot – Left Cold – Right

Run the hot and cold water supply pipes at 28 mm centres, make sure that the pipe ends project 30 mm into the inlet manifold.

Warning! Supply connections **must not** be connected in reverse.

Caution! Do not use stainless steel piping for inlet pipework.

Caution! If the pipework is chrome plated remove all traces of chrome from the connecting surfaces. If the chrome is not removed then the inlet manifold collets will **not** grip the supply pipe.

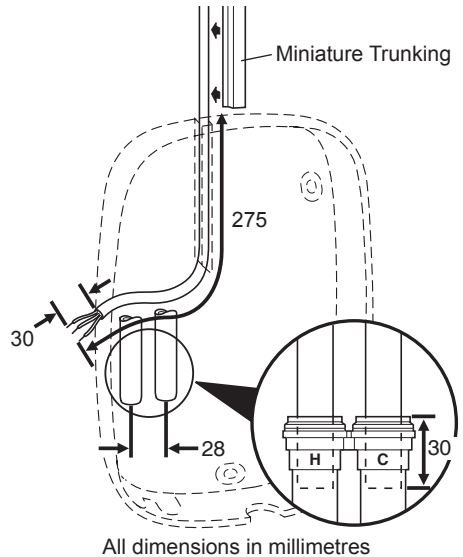

3. Make sure that the end of the supply pipework is cut squarely and is **free from burrs**, which will damage the inlet manifold seals.

Chamfer the end of the pipe to assist insertion into the fitting and prevent the 'O' seal tearing.

Warning! Do not insert fingers into the push-fit connectors as this can result in injury.

Caution! Thoroughly flush the incoming hot and cold water supply pipes to remove debris before connecting the shower unit.

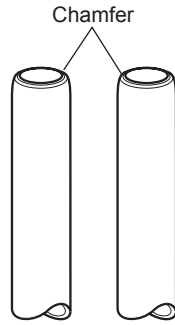

4. Run the electrical supply cable in surface mounted miniature trunking (not supplied). Allow sufficient cable to connect to the terminal block (approximately 275 mm). Strip back approximately 30 mm of outer cable insulation.

Trim the thinned section of the case covering the cable channel.

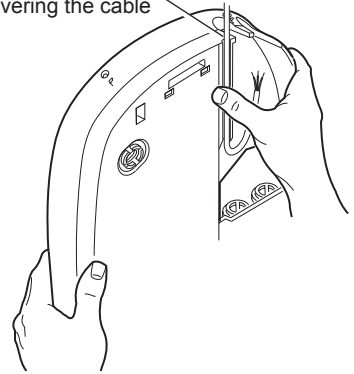

5. Loosen the three cover securing screws and remove the shower unit cover.

Note! The cover securing screws are captive and should **not** be unscrewed fully from the unit case.

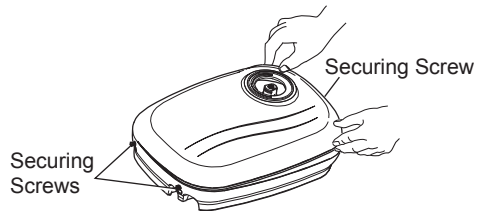

6. Insert the push-fit release tool between the flange of the blanking plug and the inlet manifold collet and lever the plugs outward. Whilst holding back on the collet, pull out the appropriate blanking plug by hand.

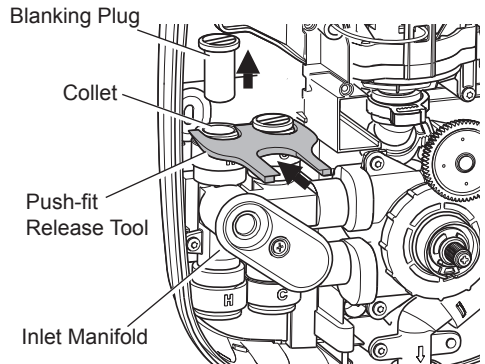

7. Temporarily locate the shower unit.

8. Position the shower unit on the wall and mark the three fixing points.

Note! Installers may wish to obtain alternative proprietary cavity fixings for dry lined, stud partition or dry partition wall structures.

9. Use the push-fit release tool to push the grey collars into the manifold to release the shower unit from the supply pipes.

Warning! Make sure there are no buried cables or pipes near the fixing points before drilling.

10. Drill 9.5 mm holes and fit the wall plugs supplied.

11. Cut away and trim the thinned section at the top or bottom of the case to allow the electrical supply cable to run down the rear of case.

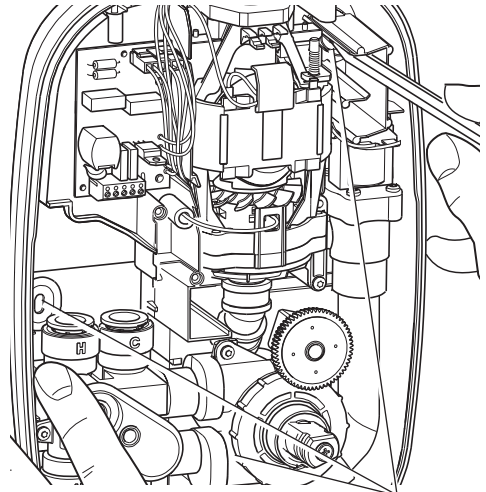

Fixing Points

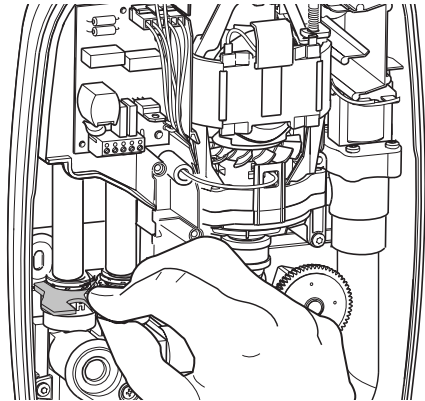

12. Fit the three rubber feet into the recesses in the rear of the case as shown. The feet will reduce the noise transmitted by the power shower through the wall.

Warning! Blanking plates should be fitted to stop water ingress into the inside of the unit.

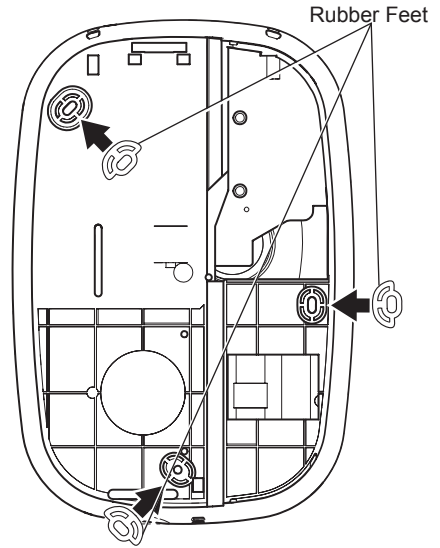

13. Fit the blanking plates to the unit case in the following manner.

For Top Inlet Pipework

Fit the half blanking plate to the top of the case.

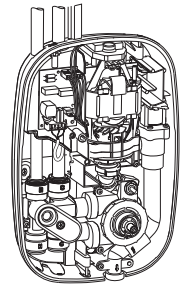

Fit the full blanking plate to the bottom of the case.



For Rear Inlet Pipework

Fit the full blanking plates to the top and bottom of the case.

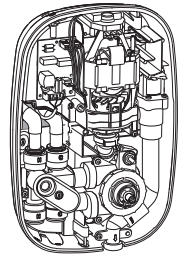

Fit the full blanking plate to the top of the case.



For Bottom Inlet Pipework

Fit the half blanking plate to the bottom of the case.

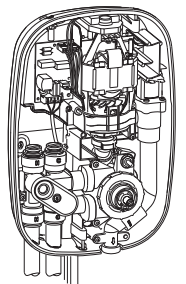

14. Locate the shower unit on the inlet supplies and push the inlet manifold onto the pipework until resistance is felt.

DO NOT FORCE!

Note! PTFE tape or liquid jointing compound must not be used and is **not** required to assist connection.

15. The inlet manifold collet and 'O' seals will seal automatically.

Warning! The shower unit **must** be fixed to the wall at all three fixing points. The fixing holes are elongated to assist in vertical and horizontal alignment.

16. Screw the shower unit to the wall using either the wall screws supplied or alternative fixings depending on the wall structure.

Do not over tighten!

Make sure that the electrical supply cable is correctly seated in the channel in the back of the case.

17. Connect the live, neutral and earth conductors of the electrical supply cable to the terminal block in the following manner.

L - Live terminal block

N - Neutral terminal block

⏏ - Earth terminal block

The earth supply cable must be sleeved and make sure that all the terminal connections are tight and that no insulation is pinched.

18. Make sure the flow control gear drive is set to the OFF position. Turn the gear wheel **anticlockwise** until the gear drive microswitch emits a click noise to indicate the gear drive is in the OFF position.

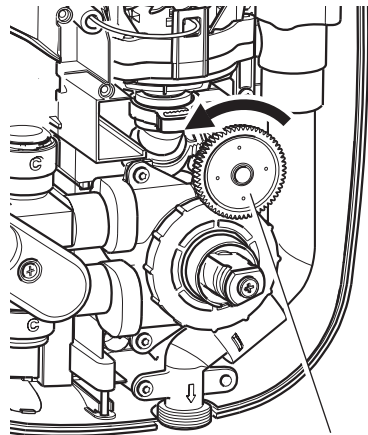
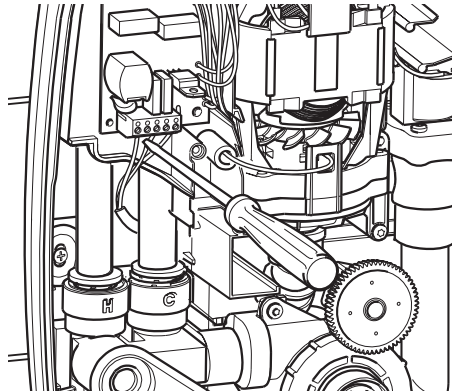
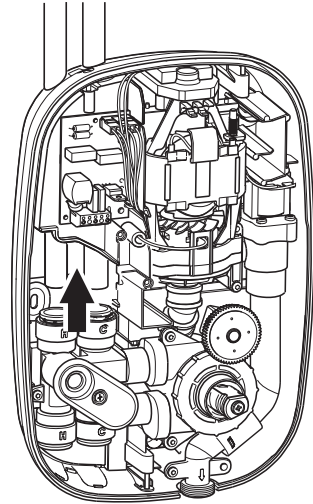

Gear Wheel

19. Refit the unit cover and secure with the three cover securing screws.

20. Insert the flow control knob in the OFF position.

21. Insert the temperature indicator trim and the inner temperature control knob.

22. The power thermostatic shower will now require commissioning, refer to **COMMISSIONING**.

23. Install the shower fittings, refer to the instruction manual supplied with the fittings.

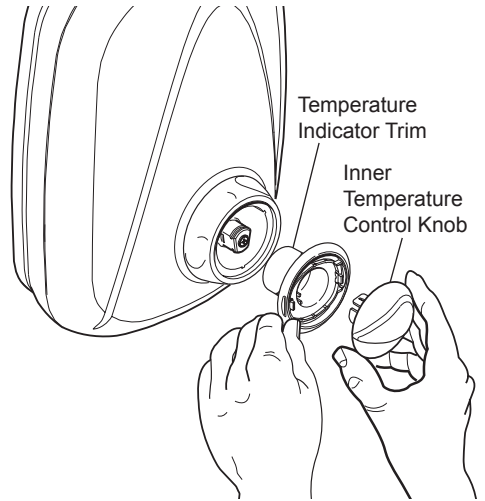
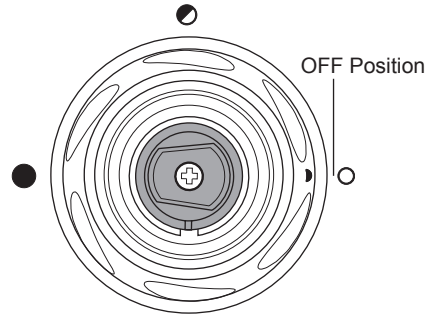

COMMISSIONING

The unit **must not** be run dry. Before proceeding any further with the installation the shower unit must be commissioned.

1. Connect the flexible hose to the outlet of the shower unit.

Caution! Do not over tighten.

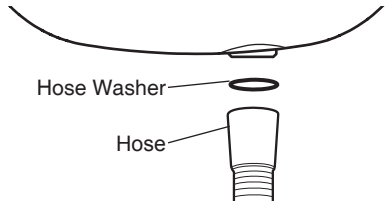

2. Turn on the water supplies and check for leaks.

3. Switch on the electrical supply.

4. Turn the outer flow control **anticlockwise** to full flow.

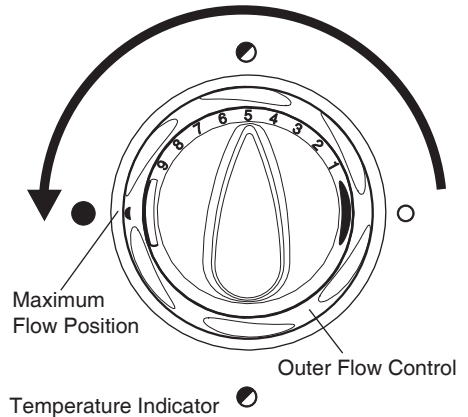

5. Rotate the inner temperature control anticlockwise to check the hot supply and clockwise to check the cold supply.

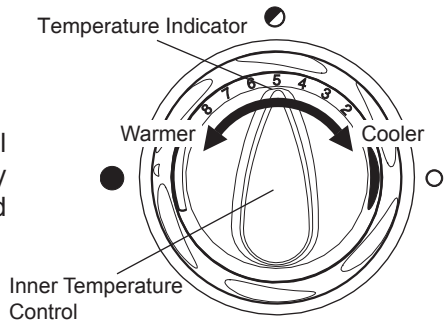

6. Turn the flow control **clockwise** to the **OFF** position.

7. The shower unit is now commissioned.

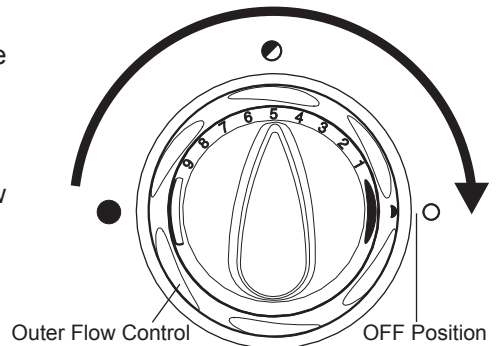

Maximum Temperature Setting

It may be necessary to adjust the maximum temperature for site conditions to make sure of safe showering from the unit. Make sure that the hot water temperature is at least 12 °C above the required temperature for correct operation of the thermostatic power shower.

To reset the maximum outlet temperature follow the sequence below :

1. Turn the outer flow control **anticlockwise** to maximum flow.

2. Turn the inner temperature control knob **anticlockwise** to the maximum temperature stop. **Do not depress the override button.**

3. Check the shower temperature.

4. If the maximum temperature requires adjustment then remove the outer flow control and the inner temperature control knobs. Slide the end of the push-fit release tool under the outer flow control, lever the outer flow control and the inner temperature control knobs off together from the shower unit.

5. Remove the small label covering the retaining screw on the temperature hub. Unscrew the retaining screw and remove the temperature hub.

Note! This will void the factory setting.

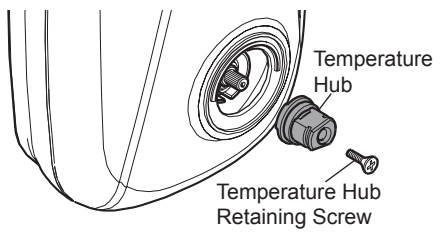
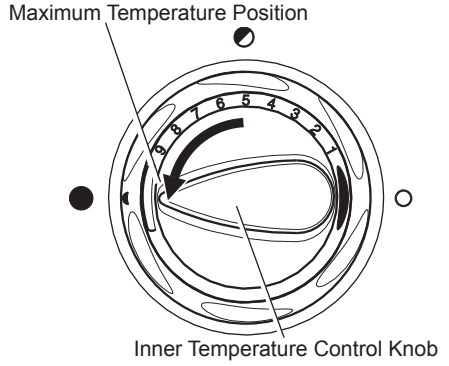
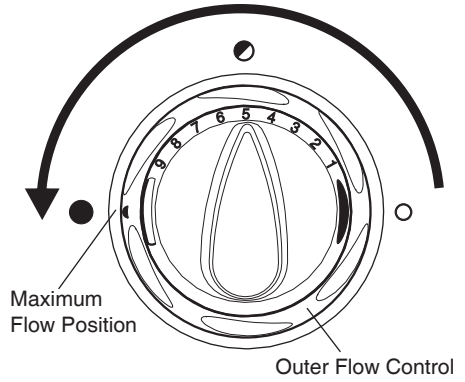

Caution! When resistance is felt **DO NOT USE FORCE** to turn the spindle any further as this is the **maximum shower temperature obtainable** with the available hot water storage temperature. **FORCE** will **DAMAGE** the internal components.

- Turn the temperature spindle until the maximum water temperature required is obtained.

Warmer - Turn spindle anticlockwise

Cooler - Turn spindle clockwise

- Insert the temperature hub with the pip on the temperature hub aligned with the slot on the thermostatic cartridge. Secure the temperature hub with the retaining screw.

- Insert the outer flow control knob in the maximum flow position.

- Insert the temperature indicator trim and the inner temperature control knob.

Caution! If resistance is felt when turning the inner temperature control knob, **DO NOT USE FORCE** to turn the knob any further as this will **DAMAGE** internal components.

- Make sure the inner temperature control knob can be fully turned in both directions.

- Check the maximum temperature setting. If necessary repeat the temperature adjustment until the required temperature is achieved.

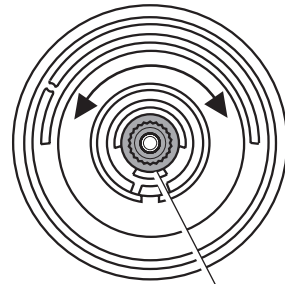

Temperature Spindle

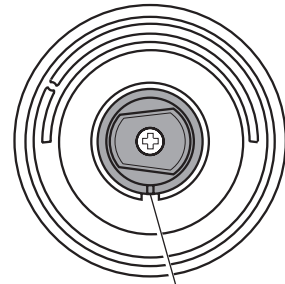

Align the pip on the temperature hub with the slot in the thermostatic cartridge.

Temperature Indicator Trim

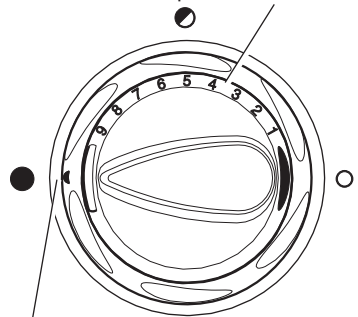

Maximum Flow Position

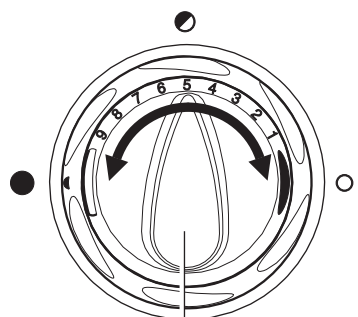

Inner Temperature Control Knob

Disabling the Temperature Override Button

The temperature override button allows the user to override the preset maximum temperature. The temperature override button should be disabled if the power shower is to be used by the young, the elderly, the infirm, or anyone inexperienced in the correct operation of the controls.

Follow the instructions below to disable the temperature override button:

1. Turn the outer flow control knob **clockwise** to the off position and the inner temperature control knob **clockwise** to full cold.
2. Slide the end of the push-fit release tool under the outer flow control knob and lever the control knob assembly off the shower unit.
3. Unclip the concealed end of the override button from the temperature indicator trim and carefully remove the override button.
4. Rotate the override button through half a turn (180°) and refit. Make sure the override button is flush with the temperature indicator trim.
5. Insert the outer flow control knob in the off position.
6. Insert the temperature indicator trim and the inner temperature control knob. Make sure the inner temperature control knob is pushed fully onto the temperature hub.
7. The temperature override button is now disabled.

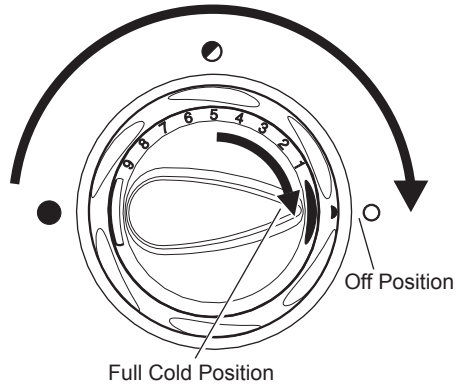

Full Cold Position

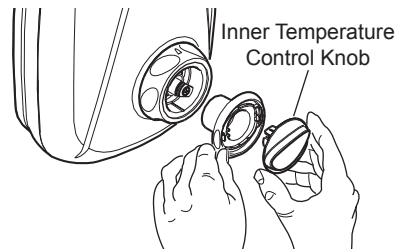
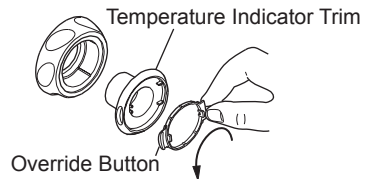
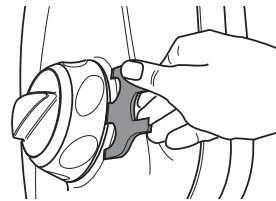

OPERATION

For safety reasons this appliance is fitted with an adjustable maximum temperature setting. This must be checked and adjusted as necessary to suit both site conditions and user's comfort.

1. Turn the outer flow control knob until the desired flow of water is obtained. The flow of water will increase the further the control is turned **anticlockwise**.

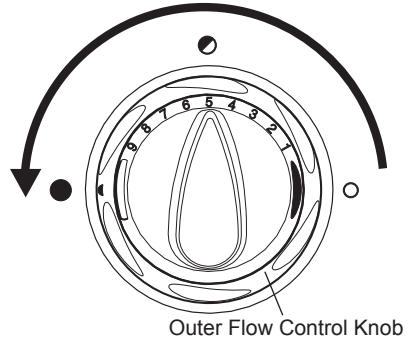

2. Turn the inner temperature control knob anticlockwise for warmer water and clockwise for cooler water, the numbers indicate the relative temperature:

1 = cold, 4 = tepid, 7 = Hot

Warning! Operation of the override button will allow a shower temperature above the preset maximum.

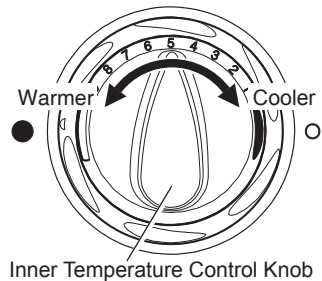

3. To override the preset maximum temperature press the override button and turn the inner temperature control knob anticlockwise.

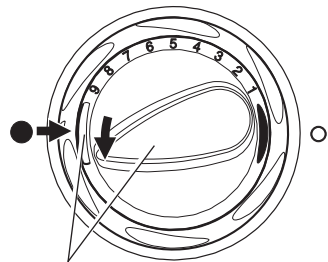

4. Turn the outer flow control knob fully **clockwise** to stop the flow of water.

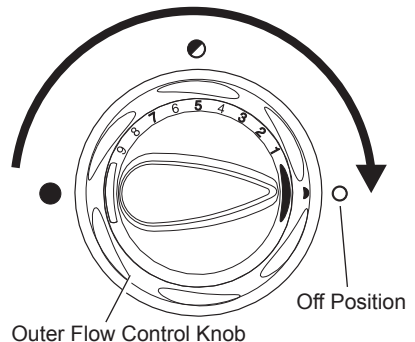

FAULT DIAGNOSIS

Fault Diagnosis - User Maintenance

The appliance is fully performance tested after assembly. Providing it has been correctly installed and is operated as advised, difficulties should not arise. In the unlikely event that you experience problems with your appliance then the following procedure will enable you to undertake basic fault finding before contacting the person responsible for installing your shower.

Malfunction	Cause	Remedy
Maximum showering temperature too hot.	Maximum temperature incorrectly set.	Reset maximum temperature, refer to COMMISSIONING .
Shower temperature too cold.	Hot water cylinder temperature less than 12 °C above shower temperature. Maximum temperature incorrectly set.	Adjust cylinder temperature. Note! It is recommended stored water temperatures do not exceed 65 °C . Reset maximum temperature, refer to COMMISSIONING .
Blend temperature unstable.	Spray plate blocked. Inlet filters blocked. Isolating valve partially closed. Plumbing system fault.	Clean spray plate, refer to the instruction manual supplied with the shower fittings . Contact your installer. Open valve. Contact your installer.
Pump does not operate.	Electrical supply failure. PCB or Potentiometer failure. Motor overheated, thermal switch operated.	Contact your installer. Contact your installer. If the thermal switch operates repeatedly contact customer support for further advice.
Low or no water flow.	Isolating valves closed. Inlet filters blocked. Check valve fitted incorrectly. Appliance sited above cold water storage cistern. Plumbing system fault (airlock).	Open the isolating valves. Contact your installer. Contact your installer. The appliance is not suitable for negative head installations, refer to INSTALLATION REQUIREMENTS . Contact your installer.

Fault Diagnosis - Installer Maintenance

The Thermostatic Power Shower is one part of an entire plumbing system. The fitting of a pump places additional requirements on the plumbing system. Some systems may require plumbing modifications to allow them to cope with higher flow rates.

Providing the Thermostatic Power Shower has been correctly installed and is operated as advised, difficulties should not arise. Fault diagnosis and maintenance must be carried out by a competent person for whom the fault diagnosis table is provided.

In the event of any of the following tests failing, re-check as appropriate before contacting the Mira Showers Customer Support Department, refer to the **rear page**.

Malfunction	Cause	Remedy
Shower runs for a short time (30-60 seconds) then flow reduces, splutters or stops. Aggravated when other hot taps are in use. Less evident on full cold.	Air is being sucked down the vent pipe, as the hot take off to the shower is too high up the pipe.	Refer to the plumbing system diagram in the INSTALLATION REQUIREMENTS for the correct connection method. Note the 1 metre hot takeoff dimension. Consider increasing the cold feed pipe to the cylinder to 28 mm diameter.
Shower runs cool after a short time (1-2 minutes) then flow splutters.	Air entering the hot pipework.	Refer to the plumbing system diagram in the INSTALLATION REQUIREMENTS for the correct connection method.
Flow of water virtually stops and surges on/off, after a few minutes.	Insufficient storage of cold water in cistern (230 litres recommended).	Increase storage size of the cold water cistern.
Shower runs cold after 5-10 minutes.	Insufficient storage of hot water in cylinder.	Increase the storage size of the hot water cylinder.
Shower temperature affected by use of adjacent hot/cold tap.	Insufficiently sized pipework for both systems to be used together.	Increase the pipe sizes or separately feed the shower. Refer to the plumbing system diagram in the INSTALLATION REQUIREMENTS .
Maximum shower temperature too hot.	Maximum temperature incorrectly set.	Reset maximum temperature, refer to COMMISSIONING .

Malfunction	Cause	Remedy
The maximum shower temperature is too cold.	<p>Hot water cylinder temperature less than 12 °C above the showering temperature.</p> <p>Maximum temperature incorrectly set.</p>	<p>Adjust the cylinder temperature. Note! It is recommended that the stored water temperature does not exceed 65 °C.</p> <p>Reset the maximum temperature, refer to COMMISSIONING.</p>
The blend temperature is unstable.	<p>Spray plate blocked.</p> <p>Inlet filters blocked.</p> <p>Isolating valve partially closed.</p>	<p>Clean the spray plate, refer to the instruction manual supplied with the shower fittings.</p> <p>Clean the inlet filters.</p> <p>Open the isolating valve.</p>
Drip from the shower head.	Solenoid valve failure.	Renew the solenoid valve assembly.
The pump does not operate.	<p>Electrical supply failure.</p> <p>PCB failure.</p> <p>Potentiometer failure.</p> <p>Motor overheated, thermal switch operated.</p>	<p>Check the power supply.</p> <p>Renew the PCB.</p> <p>Renew the harness assembly.</p> <p>If the thermal switch operates repeatedly contact customer support for further advice.</p>
The pump does not stop or change speed when the flow knob is turned.	<p>Potentiometer failure.</p> <p>PCB failure.</p>	<p>Renew the harness assembly.</p> <p>Renew the PCB.</p>
Low or no water flow.	<p>Isolating valves closed.</p> <p>Inlet filters blocked.</p> <p>Appliance sited above cold water storage cistern.</p> <p>Plumbing system fault (airlock).</p> <p>Blocked spray plate.</p>	<p>Open the isolating valves.</p> <p>Clean the inlet filters.</p> <p>The appliance is not suitable for negative head installations, refer to the INSTALLATION REQUIREMENTS.</p> <p>Re-route the pipework to avoid airlock.</p> <p>Clean the spray plate, refer to the instruction manual supplied with the shower fittings.</p>

MAINTENANCE

Warning! There are no user serviceable components beneath the cover of the appliance. Only a competent tradesperson should remove the cover.

Before removing the cover, the electricity supply **must** be turned off at the mains and if applicable, the appropriate circuit fuse removed. Mains electrical connections are exposed when the cover is removed.

Before replacing any parts make sure that the underlying cause of the malfunction has been resolved.

Cleaning

Many household cleaners contain abrasives and chemical substances, and should not be used for cleaning plated or plastic fittings. These finishes should be cleaned with a mild washing up detergent or soap solution, and then wiped dry using a soft cloth.

Handset

Poor shower performance can be avoided by regular cleaning of the handset. Use your thumb or soft cloth to wipe the rubber nozzles. The handset must also be descaled regularly.

SPARE PARTS

147.67	Check Valve Pack
453.01	Cartridge - Thermostatic
453.03	Motor Pump Assembly - components identified 'A'
453.07	Inlet Manifold Assembly - components identified 'B'
453.08	PCB Assembly - Power
453.12	Harness Assembly - Concentric - components identified 'C'
453.13	Solenoid Valve Assembly - components identified 'D'
453.14	Filter/Cap Assembly
453.15	Seal Pack - components identified 'E'
453.22	Stud Wall Fixing Kit (Push-fit Release Tool, 3 x Fixing Screws, 3 x Rubber Wall Plugs) - components identified 'H'
453.23	Mixer Valve Body - components identified 'F'
453.24	Inserts/Rubber Feet Pack - Power - components identified 'G'
453.28	Outlet Elbow Assembly
1532.332	Control Knob Assembly
1532.365	Cover

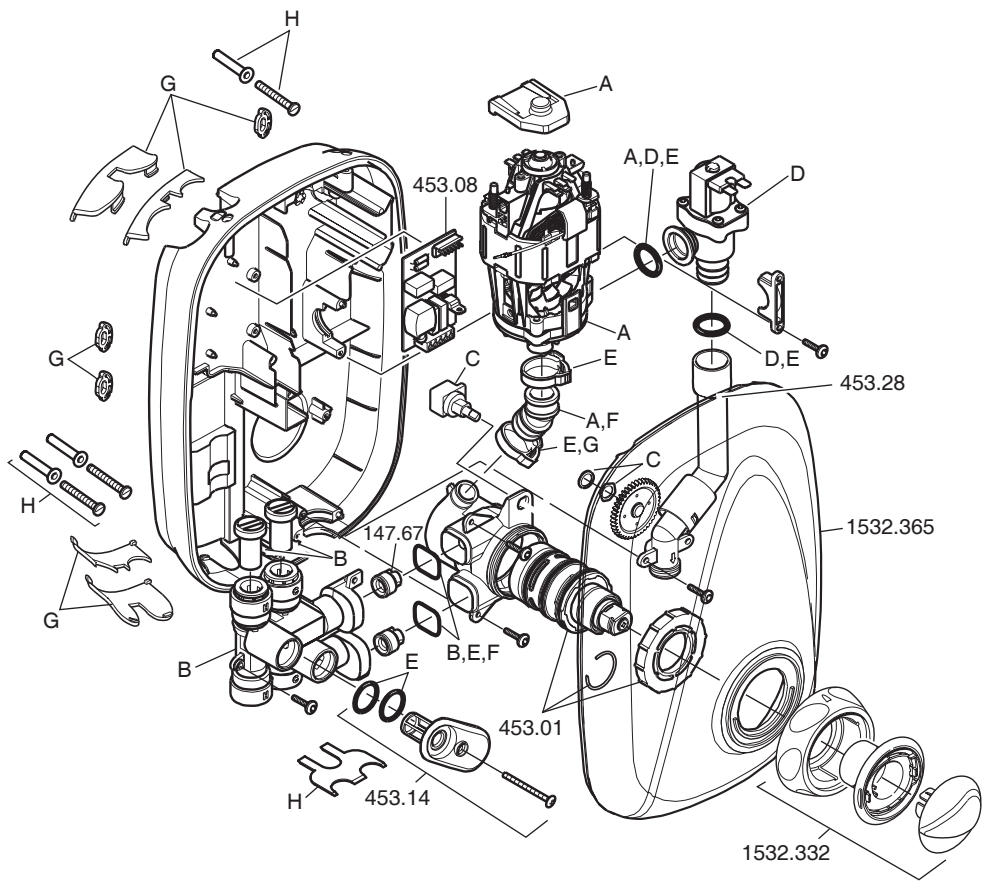

CUSTOMER SERVICE

Guarantee of Quality

Mira Showers guarantee your product against any defect in materials or workmanship for the period shown in the Guarantee Registration Document included with your shower.

Alternatively, to confirm the applicable guarantee period please contact Customer Services.

To validate the guarantee, please return your completed registration card.

Within the guarantee period we will resolve defects, free of charge, by repairing or replacing parts or modules as we may choose.

To be free of charge, service work must only be undertaken by Mira Showers or our approved agents.

Service under this guarantee does not affect the expiry date.

The guarantee on any exchanged parts or product ends when the normal product guarantee period expires.

Not covered by this guarantee:

Damage or defects arising from incorrect installation, improper use or lack of maintenance, including build-up of limescale.

Damage or defects if the product is taken apart, repaired or modified by any persons not authorised by Mira Showers or our approved agents.

This guarantee is in addition to your statutory and other legal rights.

What to do if something goes wrong

If when you first use your shower, it doesn't function correctly, first contact your installer to check that installation and commissioning are satisfactory and in accordance with the instructions in this manual. We are on hand to offer you or your installer any advice you may need.

Should this not resolve the difficulty, simply contact our Customer Services Team who will give every assistance and, if necessary, arrange for our service engineer to visit. If the performance of your shower declines, consult this manual to see whether simple home maintenance is required. Please call our Customer Services Team to talk the difficulty through, request a service under guarantee if applicable, or take advantage of our comprehensive After-Sales service.

As part of our quality and training programme calls may be recorded or monitored.

Our Customer Services Team is comprehensively trained to provide every assistance you may need: help and advice, spare parts or a service visit.

Spare Parts

We maintain an extensive stock of spares and aim to provide support throughout the product's expected life.

Spares can be purchased from approved stockists or merchants (locations on request) or direct from Customer Services.

Spares direct will normally be despatched within two working days. Payment can be made by Visa or MasterCard at the time of ordering. Should payment by cheque be preferred, a pro-forma invoice will be sent.

All spares are guaranteed for 12 months from date of purchase. Spares that have been supplied directly from us can be returned within one month from date of purchase, providing that they are in good order and the packaging is unopened.

Note! Returned spares will be subject to a 15% restocking charge and authorisation must be obtained before return. Please contact our Customer Services Team.

Note! In the interests of safety, spares requiring exposure to mains voltages can only be sent to competent persons.

Service

Our Service Force is available to provide a quality service at a reasonable cost. You will have the assurance of a Mira trained engineer/agent, genuine Mira spare parts and a 12 month guarantee on the repair.

Payment should be made directly to the engineer/agent using Visa, MasterCard or a cheque supported by a banker's card.

To Contact Us

England, Scotland, Wales and Northern Ireland

Mira Showers Customer Services

Telephone: 0870 241 0888, Mon to Fri 8:00 am - 5:30 pm
Sat 8:30 am - 3:30 pm

E-mail: technical@mirashowers.com
Fax: 01242 282595
By Post: Cromwell Road, Cheltenham,
Gloucestershire, GL52 5EP

Eire

Modern Plant Ltd (Dublin)

Telephone: 01 459 1344, Mon to Fri 9:00 am - 5:00 pm
E-mail: sales@modernplant.ie
Fax: Dublin 01 459 2329
Post: Otter House, Naas Road,
Clondalkin, Dublin 22

Modern Plant (Cork)

Telephone: 021 496 8755, Mon to Fri 9:00 am - 5:00 pm
E-mail: cork@modernplant.ie
Fax: 021 496 8607
Post: Tramore Road, Cork

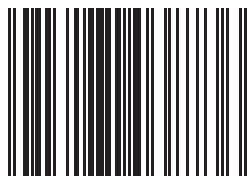

5 013181 038736 >

Mira is a registered trade mark of
Kohler Mira Limited.

The company reserves the right to alter
product specifications without notice.

www.mirashowers.com

mira
SHOWERS



FM 14648