

MGN 190 / 320 Gas Burner



MGN 190/320 Gas Burner features:

- Energy saving and compatible with environmental requirements
- Quiet in operation and designed for easy maintenance
- Designed and approved in accordance with the European Standard EN 676
- Plug-in contact facilitates the installation
- Hinged flange
- Designed for one stage, two stage, or modulating operation
- Available for natural gas, LPG, town gas, biogas
- All kW ratings are nett CV



For more information on all Nu-way products
please visit www.nu-way.co.uk



| Type | | MGN 190 | MGN 320 |
|---------------------|--------------------|--------------------------------|----------------------|
| Capacity | kW | 60-190 | 60-318 |
| Motor | V/Hz W/A (Fuse) | 230 / 50 180 / 10 | 230 / 50 250 / 10 |
| Start / Run Current | Amps | 5 / 2.3 | 8.7 / 2.2 |
| Control box | | Landis & Staefa | Landis & Staefa |
| Flame monitoring | | Ionisation | Ionisation |
| Air damper motor | | • | • |
| Operation mode | | 1 stage, 2 stage or Modulating | |
| Gross weight | kg | 27 | 29 |
| Volume | m ³ | 0.13 | 0.15 |

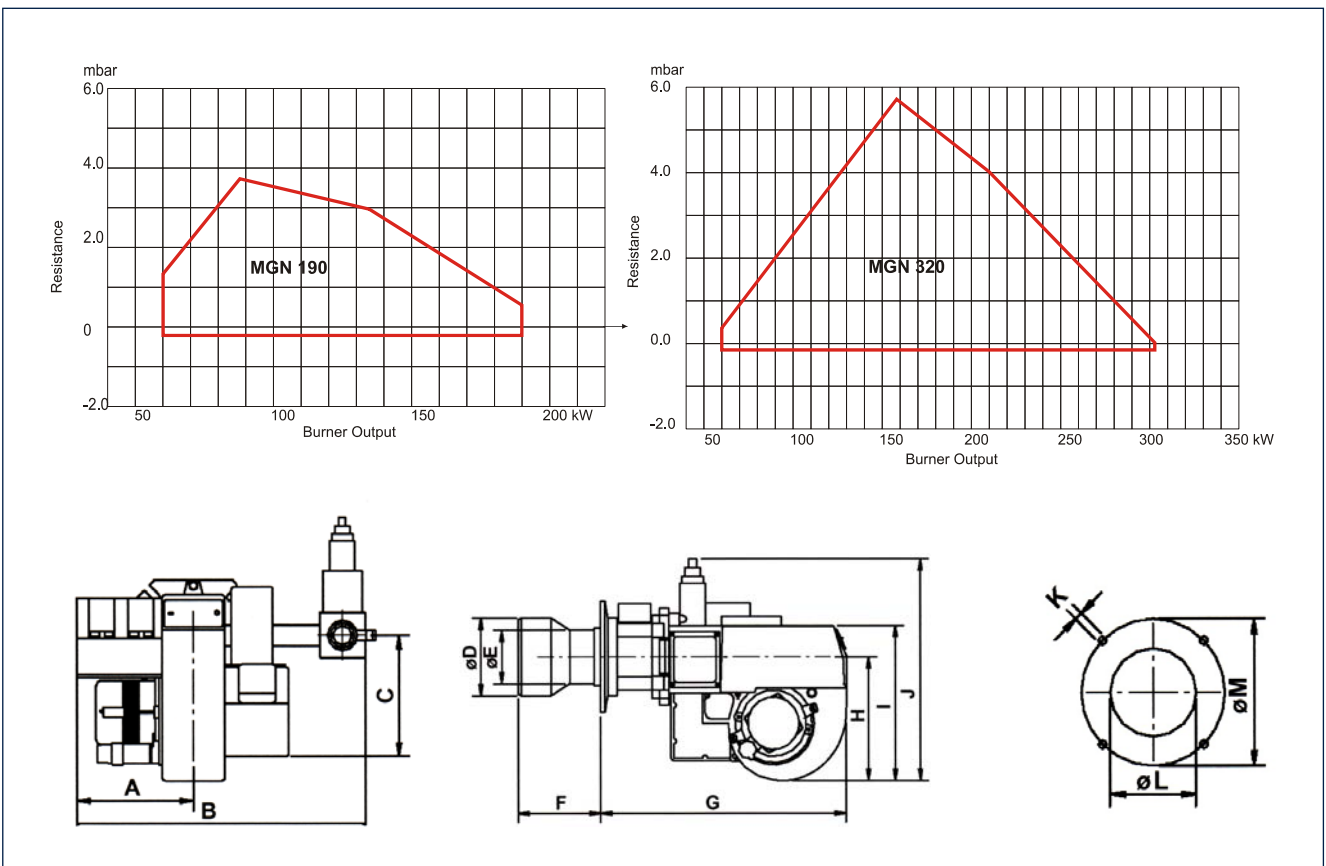

| Burner | A | B | C | øD | øE | F* | G | H | I | J | K | øL | øM |
|-------------|-----|-----|-----|-----|-----|-----|-----|-----|-----|-----|-----|-----|---------|
| MGN 190 S1L | 175 | 460 | 115 | 120 | 89 | 125 | 472 | 220 | 275 | 380 | M10 | 120 | 175-240 |
| MGN 190 T1L | 182 | 470 | 115 | 120 | 89 | 125 | 472 | 220 | 275 | 475 | M10 | 120 | 175-240 |
| MGN 320 S1L | 195 | 506 | 222 | 140 | 100 | 155 | 510 | 250 | 304 | 410 | M10 | 140 | 175-240 |
| MGN 320 T1L | 195 | 506 | 222 | 140 | 100 | 155 | 510 | 250 | 304 | 505 | M10 | 140 | 175-240 |

* Extended Lengths Available

Enertech Limited, P O Box 1, Vines Lane
Droitwich, Worcestershire, WR9 8NA

tel: +44 (0) 1905 794331 • fax: +44 (0) 1905 794017
email: info@nu-way.co.uk • web: www.nu-way.co.uk



Issue 1 6/10