

Installation, Operating, Maintenance  
and After Sales Manual.

HI-LINE RC & HI-LINE RC Heater/Cooler  
Models: 7-4, 10-6, 15-10, 20-14

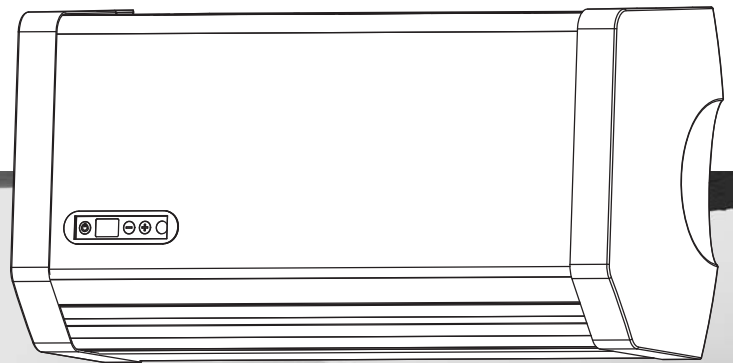

**heating**through**innovation.**

Product Serial Number:

--	--	--	--	--	--

Please leave this manual with the end user.

Part Number: 1370056

Issue 5

For latest prices and delivery to your door visit MyTub Ltd - [www.mytub.co.uk](http://www.mytub.co.uk) - [info@mytub.co.uk](mailto:info@mytub.co.uk) 0844 556 1818



## Contents

<b>1.0</b>	General Information	03
<b>2.0</b>	Heating System Design	03
<b>3.0</b>	Unit Selection/Sizing	03
<b>4.0</b>	Location	03
<b>5.0</b>	Preparation	04
<b>6.0</b>	Fixing	04
<b>7.0</b>	Water Connections	05
<b>8.0</b>	Electrical Connection	06
<b>9.0</b>	Commissioning Procedure	06
<b>10.0</b>	Technical Data	08
<b>11.0</b>	Operating Instructions	09
<b>12.0</b>	Troubleshooting	10
<b>13.0</b>	Maintenance	11

## 1.0 General Information

- This MYSON HI-LINE RC fan convector is designed for wall-mounted installation with a maximum installation height of 2.13m to the underside of the unit.
- The minimum installation height is 1.8m to the underside of the unit.
- The minimum clearance between the top of the unit and the ceiling should be 50mm.
- The minimum side clearance is 100mm.
- The HI-LINE RC should only be used on closed circulation, two pipe, pump assisted central heating systems (HI-LINE) or heating and cooling systems (HI-LINE Heater/Cooler).
- Before proceeding with the installation, the heating system design must be considered and the unit correctly sized to meet the heat loss requirements of the room at normal fan speed.
- This unit is supplied with an infra red remote control system and has 3 operating modes -

Automatic – the desired room temperature is programmed in to the unit and the fan speed is automatically adjusted until the desired room temperature is achieved.

Fan only – allows user selection of any of the 3 available fan speeds irrespective of room temperature or water temperature in the coil.

Fan only with water temperature control – allows the user to select any of the available fan speeds, which will operate only if the water temperature in the coil is above 32C. This enables control of the unit via an externally mounted room thermostat if desired.

- The appliance is not intended for use by persons (including children) with reduced physical, sensory or mental capabilities, or lack of experience and knowledge, unless they have been given supervision or instruction concerning use of the appliance by a person responsible for their safety.

Children should be supervised to ensure that they do not play with the appliance.

1.0

2.0

3.0

4.0

This unit **MUST NOT** be installed in a bathroom or other similar high humidity area.

## 2.0 Heating System Design

This fan convector must be fitted on a two pipe, pumped circulation heating system.

For optimum fan convector heating performance the system must be capable of providing sufficient hot water through the heat exchanger. This means that:

1. The minimum pipe size from boiler to fan convector must be 15mm.
2. **This unit is not suitable for use on microbore pipework.**
3. Where the unit is fitted on to a system with other emitters a separate circuit for the fan convector should be considered to provide adequate water flow.

4. The system water must be above 32°C for heating mode.
5. For heat pump applications - see Commissioning Procedure.
6. **This unit is NOT suitable for one-pipe systems.**
7. **Optimum performance will require effective balancing of the whole system.**
8. This unit should NOT be used to replace a radiator in an existing system unless an adequate flow of water can be guaranteed.

## 3.0 Unit Selection/Sizing

Heat output performance is given in the Technical Data section of this manual. Outputs are shown for the 3 fan speeds, however, it is important to size the unit to match the calculated heat loss requirements of the room with the unit operating on the low fan speed. The higher fan speeds are used in automatic mode when the room temperature is significantly lower than the

preset temperature.

When establishing the temperature difference, ie mean water to room temperature, allowance should be made for temperature drop in the system. It is the water temperature at the unit which dictates the output.

## 4.0 Location

- This HI-LINE RC unit may be fitted to any convenient wall at a height from floor level that suits the application, providing an unimpeded flow of warm air into the area to be heated.
- The maximum distance from the underside of the unit to floor level is 2.13m.
- The minimum distance to the underside of the unit is 1.8m.

- This unit should not be installed in locations with ceiling heights greater than 3m.
- The unit should be mounted on a flat wall, and stud or partition walls should be avoided to minimise the possibility of noise transmission.
- For cooling applications, the need for disposal of condensate may influence the position of the unit.

## 5.0 Preparation

Before proceeding with the installation, unpack the carton contents and check against the checklist below:

1. HI-LINE RC fan convector.
2. 15mm isolating valves (1 pair).
3. Instruction manual.
4. Warranty card.
5. Fixing kit (rubber mounts and cable gland).
6. Remote control handset.

## 6.0 Fixing

- Using the fixing dimensions below (see fig. 1), mark the fixing hole positions on the wall.
- Drill and plug the wall for No. 8 x 40mm round head wood screws ensuring that the wall plugs are suitable for the wall type.
- Remove the backing from two of the self-adhesive washers and place on two of the screws with adhesive side towards the point.
- Tighten the screws into the top two fixing holes leaving about 9mm projecting.
- Press adhesive washers to the wall.
- Remove the backing from the last self-adhesive washer and place centrally over the bottom fixing hole on the left hand side.

Remove the outer casing as follows:

- Remove the 2 screws at each end of the outlet grille (see fig. 2).
- Lift off the outer case.
- Fit chassis on to the top two mounting screws and tighten.
- Secure the bottom fixing point with the remaining screw.

**Note:** Before proceeding with pipe-work connections check that the unit is level. If the right hand end is lower than the left then the ability to vent the unit may be restricted.

When water connections and electrical connections have been completed and the unit has been vented, fit the outer cover and secure with fixing screws.

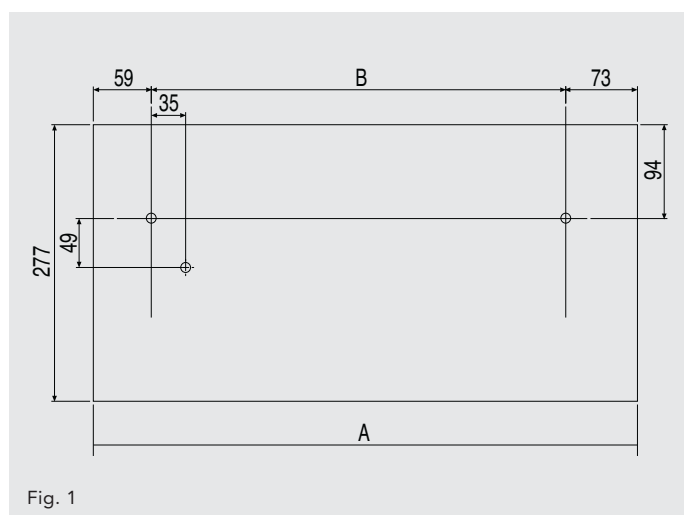

Fig. 1

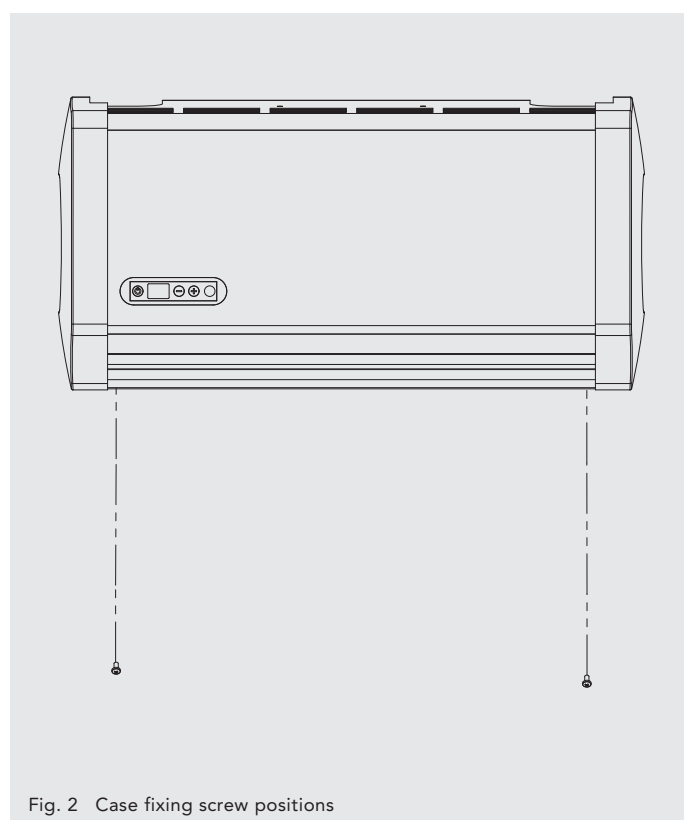

Fig. 2 Case fixing screw positions

Unit	Dimensions (mm)	
	A	B
20-14	1171	1039
15-10	887	754
10-6	682	550
7-4	554	422

**7.0 Water Connections**

- Connect unit to system flow and return pipes using the two 15mm isolating valves (see fig. 3).
- Ensure system is flushed in accordance with recognised best practice and a suitable inhibitor is added to the system as necessary.
- Open valves fully, check pipe connections for leaks and vent the heat exchanger - see Commissioning Procedure.

**Note:** External pipe-work carrying chilled water must be insulated. Use a suitable sealant as necessary to ensure that condensate does not spill or leak.

HI-LINE Heater/Cooler installations with chilled water will require provision for condensate disposal in accordance with any local regulations.

A drain tray is fitted for condensate collection within the unit. This should be connected to a 15mm drain pipe.

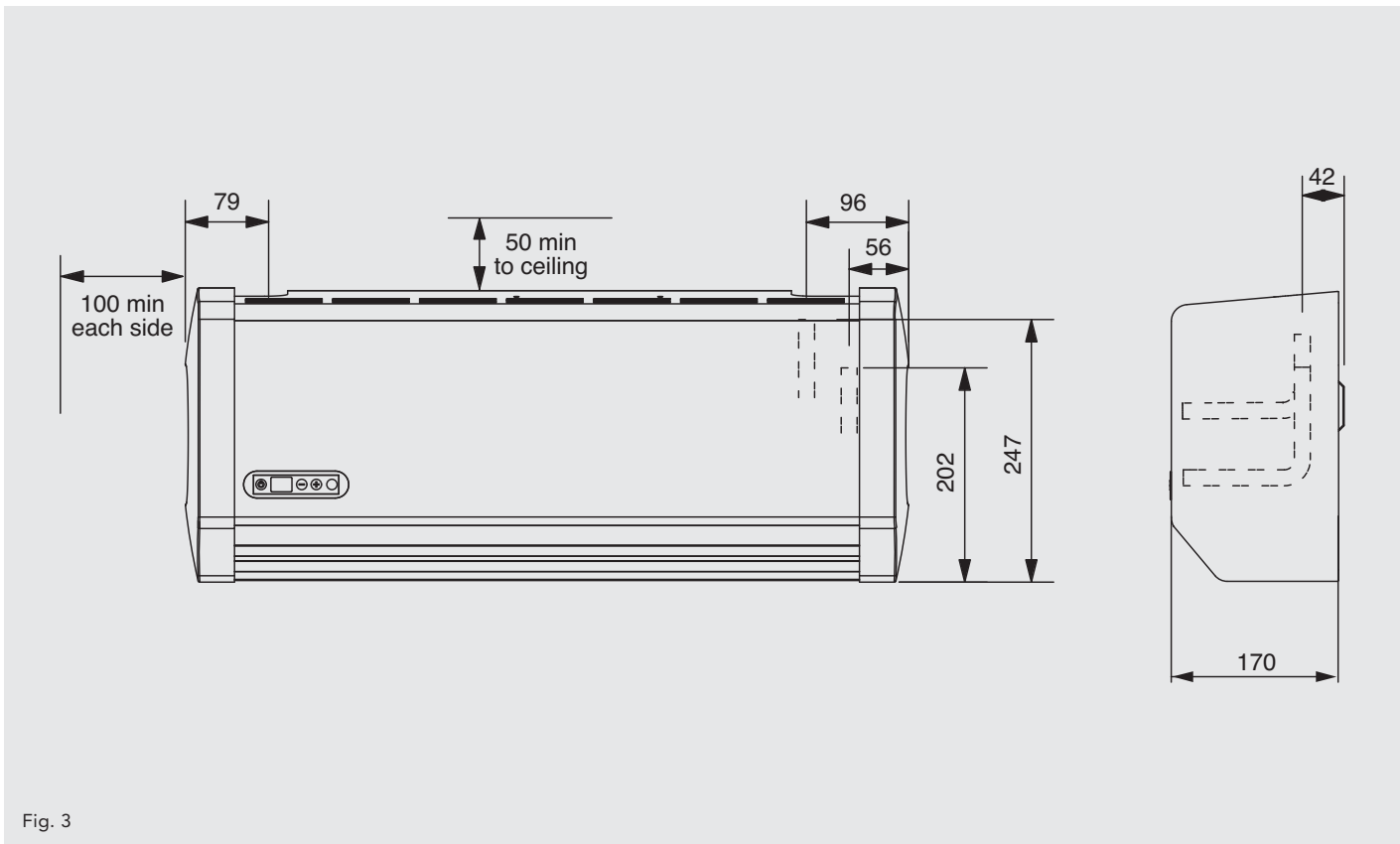

5.0  
6.0  
7.0

## 8.0 Electrical Connection

**WARNING:** This appliance must be earthed. The electrical installation must comply with local or national wiring regulations.

- This unit is supplied with factory fitted test leads. Remove these and discard.
- A fused electrical spur with a maximum 3A fuse and a switch, having 3mm separation on all poles, must be provided in an easily accessible position adjacent to the unit.
- Electrical cable entry to the unit should be made through the hole provided at the top left hand side of the unit, using the cable gland provided.
- Connect live and neutral wires to the power board terminal connections, and the earth wire to the chassis earth terminal.

Wiring diagram

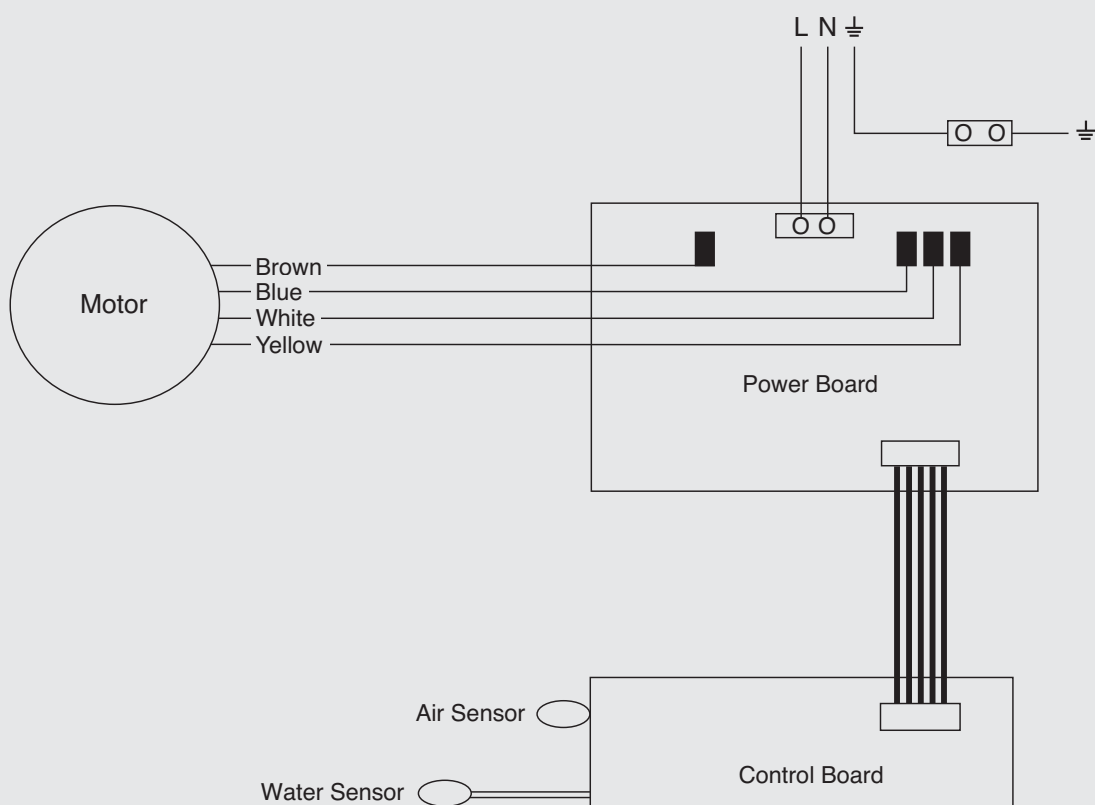

## 9.0 Commissioning Procedure

- Fill and vent the system.
- Open both valves fully and check for leaks at pipe connections.
- Refit the outer case and secure using the 2 fixing screws.
- Switch on electrical supply.
- Check the operation of the unit by following the operating instructions.
- When installation and commissioning are complete, hand over instruction manual to end-user.

**9.0 Commissioning Procedure (continued...)**

**Heat Pump and Low Water Temperature Systems**

In heating mode, the control system brings the fan on when the water in the coil reaches 32°C. For low water temperature systems, eg heat pump systems, it is possible to switch off the boost speed option in automatic mode so that the unit runs in medium or normal fan speeds depending on demand. This means low outlet air temperatures from the unit are avoided when the room temperature is low in relation to the set temperature.

This facility can be switched on or off by following the instruction below

- Isolate electrical supply.
- Remove outer cover.
- Change switch 1 position according to requirements (see fig. 4).
- Refit outer cover.
- Switch on electrical supply.

**Displayed Temperature Calibration**

Depending on the location of the unit there may be a difference between the temperature at the unit and the temperature in the middle of the room being treated.

The displayed temperature calibration function enables calibration in heating mode of the displayed temperature to the actual room temperature using the following procedure:

- Press the On/Off key and + key simultaneously for 5 seconds. The display will flash, alternating between 'ro' and the calibration temperature.
- Calibrate the displayed temperature by using the + and – keys with the fan running.
- Press the On/Off key to finish.

**Fan Pulse**

Fan pulse mode causes room air to be drawn over the air temperature sensor periodically to maintain room temperatures more effectively. In certain circumstances, for example when units are over-sized in relation to the heat loss of the room, it may be necessary to turn off this function. Use dipswitch 3 according to requirements.

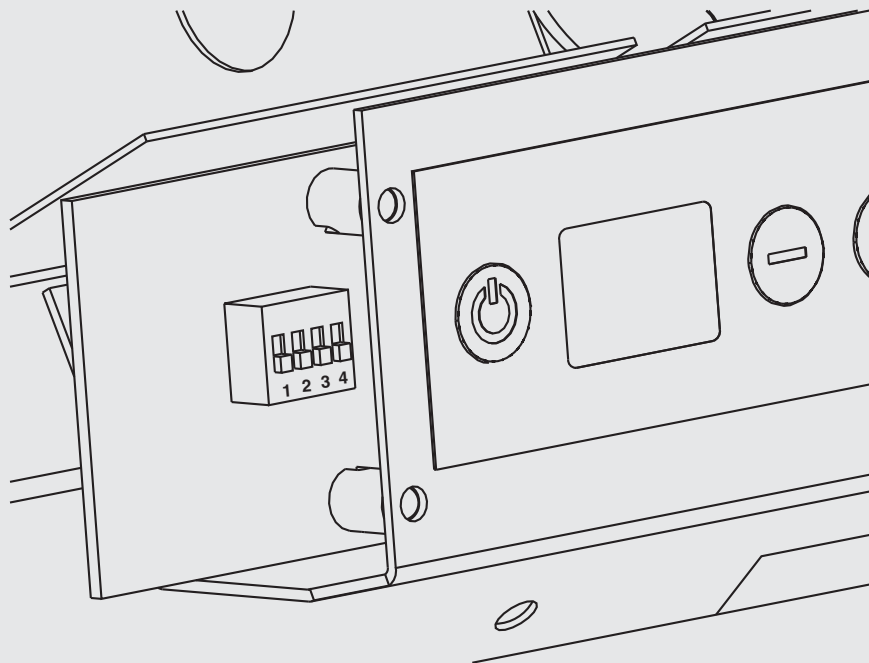

Fig. 4

Switch		Switch Down	Switch Up
1	Auto Fan Speed Selection	2 Speed	3 Speed
2	Heating / Cooling	Heating	Heating & Cooling
3	Fan Pulse	Off	On
4	Temperature Display	°F	°C

8.0  
9.0

**10.0 Technical Data**

**Heating Performance Data**

Model	Fan Speed	Heat Output (watts)						Heat Output (Btu/h)					
		Temperature Difference (°C)						Temperature Difference (°F)					
		40°	45°	50°	55°	60°	65°	72°	81°	90°	99°	108°	117°
20-14	Normal	2737	3101	3468	3836	4207	4579	9339	10581	11831	13089	14354	15625
	Medium	3457	3917	4380	4845	5314	5784	11796	13365	14944	16533	18130	19735
	Boost	3917	4436	4959	5485	6014	6545	13363	15136	16920	18715	20518	22331
15-10	Normal	1941	2199	2459	2721	2983	3248	6625	7504	8391	9282	10179	11081
	Medium	2197	2489	2783	3079	3376	3675	7495	8492	9495	10504	11519	12539
	Boost	2913	3300	3690	4082	4477	4873	9939	11260	12591	13929	15275	16628
10-6	Normal	1271	1440	1610	1781	1953	2126	4336	4912	5493	6076	6664	7254
	Medium	1546	1752	1959	2167	2376	2587	5276	5977	6684	7394	8109	8827
	Boost	1990	2255	2521	2789	3059	3330	6971	7694	8603	9517	10437	11361
7-4	Normal	734	831	930	1029	1128	1228	2504	2837	3172	3509	3848	4189
	Medium	1020	1156	1292	1430	1568	1707	3481	3944	4410	4879	5350	5824
	Boost	1344	1522	1702	1883	2065	2248	4584	5194	5807	6424	7045	7669

Heat outputs tested in accordance with BS 4856 Part 1.

Flow rate 340 ltr/h (75 gal/h).

Flow Rate Correction Factors:

455 ltr/h (100 gal/h) multiply by 1.06.

227 ltr/h (50 gal/h) multiply by 0.96.

113 ltr/h (25 gal/h) multiply by 0.85.

**Approximate Hydraulic Resistance through Fan Convectors**

Litres/h	mm wg				kPa			
	7-4	10-6	15-10	20-14	7-4	10-6	15-10	20-14
455	1084	1240	1500	1774	9.4	12.12	14.7	17.42
340	798	657	905	1140	7.7	6.42	8.9	11.2
227	350	327	450	565	3.5	3.25	4.37	5.5
113	134	105	157	221	1.4	1.1	1.57	2.1

**Cooling Performance Data**

Model	Fan Speed	Cooling Performance (watts)						Cooling Performance (Btu/h)					
		Air-Mean Water Temperature Difference (°C)						Air-Mean Water Temperature Difference (°F)					
		15°		20°		25°		27°		36°		45°	
		Tot.	Sens.	Tot.	Sens.	Tot.	Sens.	Tot.	Sens.	Tot.	Sens.	Tot.	Sens.
20-14	Normal	1256	1034	1922	1291	2676	1421	4284	3530	6557	4405	9131	4849
	Medium	1510	1241	2312	1597	3220	1759	5153	4234	7887	5449	10985	6002
	Boost	1601	1363	2449	1770	3408	1879	5462	4650	8354	6039	11628	6412
15-10	Normal	886	761	1355	1002	1886	1091	3022	2598	4624	3420	6435	3721
	Medium	958	815	1466	1058	2041	1123	3268	2781	5001	3609	6965	3833
	Boost	1276	1093	1953	1434	2719	1549	4354	3730	6664	4892	9276	5284
10-6	Normal	578	490	884	635	1230	668	1971	1671	3016	2166	4195	2279
	Medium	646	545	988	704	1375	736	2202	1861	3370	2404	4690	2512
	Boost	780	638	1194	867	1662	1098	2662	2178	4074	2957	5671	3748
7-4	Normal	318	274	487	362	678	396	1085	936	1663	1237	2313	1352
	Medium	473	405	725	531	1009	574	1614	1383	2473	1813	3443	1959
	Boost	574	459	878	623	1222	790	1957	1567	2995	2126	4170	2695

Cooling performance tested in accordance with BS 4856 Part 2. Flow rate 340 ltr/h. Relative humidity 50%.

**Noise Levels**

Model	Sound Pressures at 2.5m (dBA)		
	Normal	Medium	Boost
20-14	33.3	38.7	45.4
15-10	28.8	35.4	45.6
10-6	23.5	30.8	37.2
7-4	23.4	32.5	43.3

Noise levels tested in accordance with EN 23741.

**Weight, Water Content and Motor Power**

Model	Motor Power (W)	Water Content (l)	Unpacked Weight (kg)
20-14	80	0.30	7.4
15-10	62	0.32	8.9
10-6	35	0.56	11.3
7-4	35	0.77	14.7

Test Pressure 20bar (2 MPa) Maximum working pressure 10bar (1MPa)  
Water connections 15mm Electrical supply 230V - 50Hz



**11.0 Operating Instructions**

**Description**

This HI-LINE unit is fitted with a control system that provides 3 different operating modes. In automatic mode the desired temperature set point is selected and the unit will adjust the fan speed according to the difference between the actual room temperature and the set point. When the room temperature reaches the set point the fan will switch off and thereafter will continue to cycle on and off to maintain the room temperature. The temperature set point range is 15 - 35°C.

In manual mode the automatic temperature control is overridden and any of the three fan speeds can be operated irrespective of the water temperature in the unit. This means that air circulation can be provided in summer for example, or that heating performance can be controlled manually.

In manual mode, with water temperature control, any of the 3 fan speeds can be selected and the fan will operate when the water temperature in the coil is greater than 32°C. This means that heating performance can be controlled manually, and the unit could be controlled via an external room thermostat.

The unit can be controlled using the infra red remote control handset supplied with the unit (see fig. 5) and also using the control panel on the unit (see fig. 6). If necessary, however, the control panel can be locked electronically to prevent tampering once the controls have been set (see over).



Fig. 5

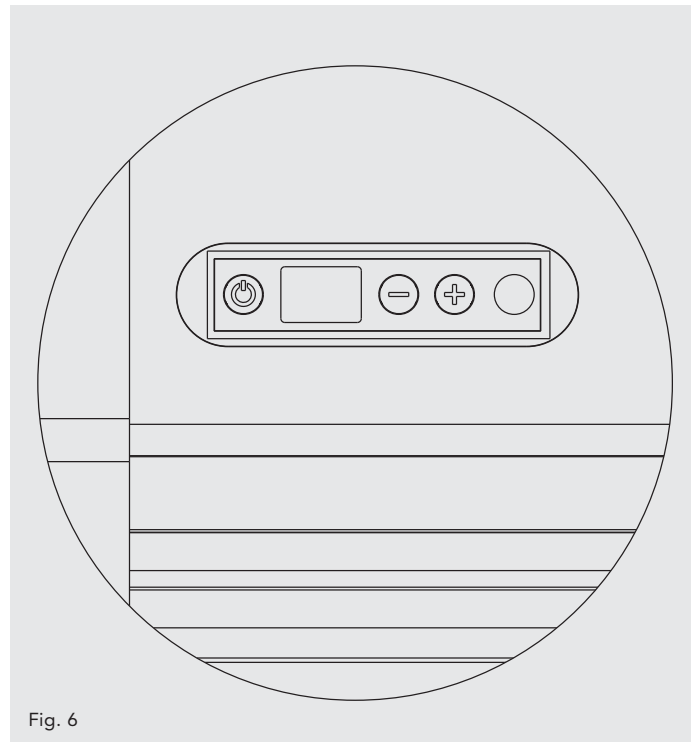

Fig. 6

The remote control hand set takes 2 AAA batteries (not supplied).

**Controls**

Power button  
'+/-' button







**Display**

Switches unit on & off  
Adjust temperature set point from 15 - 35°C  
Scrolls into F1, F2 or F3 manual mode

**Heating**

The unit will only operate in heating mode when the central heating boiler is on, the pump is running and the system water temperature is greater than 32°C. Ensure the boiler is on, and set timer, boiler controls and room thermostats as necessary.

**11.0 Operating Instructions (continued...)**

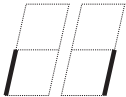
Operation	Display
Power off	No Display
Switch on supply to unit (unit off)	 for 30 seconds
Switch on unit	 Supply on / unit off
	 Set point flashes for approx 5 secs, then
Use '+/-' to adjust set point	 Ambient temperature displayed
	 Set point flashes for approx 5 secs, then
	 Ambient temperature
Water temp <32°C	 Shows both power & unit on

\*32°C in heating and above 20°C in cooling.

**Manual**

Manual mode can be used for air circulation without heat or for manual control of the heating function.

Use '+' to scroll beyond 35°C  
Or use '-' to scroll below 15°C

Selected fan speed displayed



Scrolling back out of manual using the '+' or '-' button will revert the unit back to last temperature set point.

**Cooling Mode**

- Close the heating system and isolate any other heat emitters.
- Open the cooling water system.
- Ensure cooling is on, and set cooling unit timer and controls as necessary.

Cooling operation works in exactly the same way as heating. Follow the procedure above to set the unit controls.

**Locking Unit Controls**

The control panel on the main unit can be locked electronically to prevent interference once the controls have been set. After setting the unit to the desired temperature setting and with the unit in running mode, press the On/Off button on the main unit for about 6 seconds until the two middle horizontal bars appear on the display. The horizontal bars will disappear after about 6 seconds and the unit is in key lock mode.

If any of the unit controls are pressed the horizontal bars will reappear to show the key lock mode is activated, however, during this mode the handset controls remain functional.

To unlock the system press the On/Off button for about 6 seconds until the horizontal bars disappear.

**12.0 Troubleshooting**

Once installed this fan convactor becomes part of a complete heating system that generally will include boiler, pump, other emitters such as radiators and fan convectors, and a number of heating controls, dependent on system complexity. An apparent problem with this unit may be the result of system controls being incorrectly set and can be solved easily without calling out your installer or MYSON Service. Before calling your installer or MYSON Service, please carry out the checks listed opposite.

**Note:** If you call out MYSON Service to a fault detailed opposite, or to repair a fault caused by incorrect use, a call out charge will be made.

**12.0 Troubleshooting (continued...)**

Problem	Possible Causes	Remedy
Heating Mode - No Fan	Unit switched off	Turn on
	Temperature set point reached	Increase temperature set point
	Unit not switched on at fused spur	Switch on at spur
	Fuse blown at fused spur	Replace fuse
	Unit isolating valves shut	Open valves
	Water temperature reaching fan convector below 32°C (Heater model only)	Check boiler - Programmer ON  Boiler ON and set to high with central heating pump running  <b>Note:</b> Operation of fan convector can be checked by switching to manual fan setting
Heating Mode (Heater model only) poor heating performance and/or unit cycles on water sensor	Low water temperature to unit	Turn up boiler thermostat
	Poor water flow	Vent air from heating system <b>Note:</b> Operation of the fan convector can be checked by switching to manual for setting.

If the fan convector is still faulty after checking the above, call your installer or MYSON Service.

**Common Installation Faults**

For optimum performance, this unit must be correctly sized to match the heat loss requirements of the space it is required to

heat, and the heating system must be correctly designed to provide adequate flow of hot water to the unit (see Section 2). If the recommendations in Section 2 are not followed, problems may arise as detailed below.

Problem	Possible Causes
Poor heating performance (Heater model only)	Unit incorrectly sized for heat loss of room
Heating Mode (Heater model only) poor heating performance and/or unit cycles on water sensor	Boiler thermostat set too low
	Lack of flow to fan convector -
	Pump set on low setting
	Isolating valves not fully open
	System incorrectly balanced with unit starved of hot water flow
	Pipe sizing to unit too small

**13.0 Maintenance**

Before undertaking any maintenance activity isolate the electrical supply.

with warm water and mild detergent taking care to avoid water entering the grille areas.

Maintenance should be restricted to occasional removal of dust and lint around the unit. The outer surface may be wiped over



**Serial Number Location:**

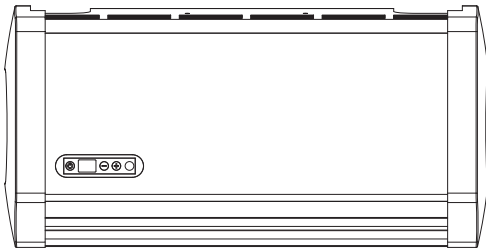

Lower/inner chassis position facing wall



**heating**through**innovation.**

**After Sales Service:**

MYSON Service, Somerden Road, Hull, East Yorkshire HU9 5PE  
T: 01482 713927, F: 01482 789056, service.convectors@myson.co.uk

Spare parts and technical help on all Convector products are available from MYSON Service.