

## Data sheet

# Lockshield valves with Pressfit connection Type RLV with isolation and regulation

### Application

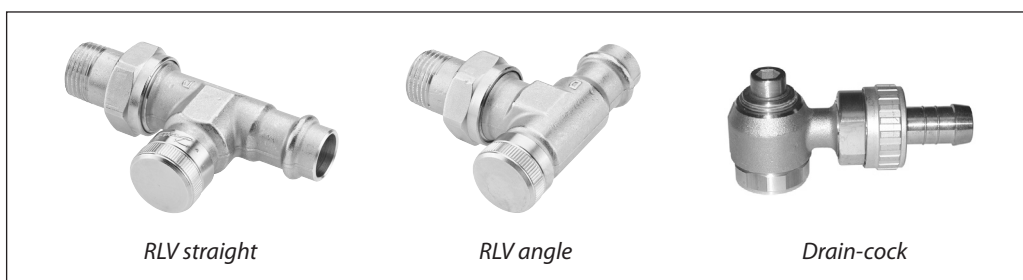

RLV straight

RLV angle

Drain-cock

The valve bodies with pressfit connection are used for heating systems with stainless steel or copper pipes.

Fitting require a commercial compression tool. List of available tools is found on page 2.

The valve bodies are physically and technically identical to RLV, DN15 standard valves.

RLV commercial lockshield valves combine the functions of isolation and regulation into a single valve body. An integrated drain-cock connection can be used together with a drain-cock accessory, which is purchased separately.

The RLV lockshield valves can be preset to limit the max. water flow. Factory setting is fully open valve,  $k_{vs} = 2.5 \text{ m}^3/\text{h}$ .

Dimensions correspond to EN (DIN) 3842-1.

Adjustment of the lockshield valve is by means of a 6 mm Allen key.

In order to avoid deposition and corrosion the composition of the hot water must be in accordance with the VDI 2035 guideline (Verein Deutscher Ingenieure).

### Ordering and data

Type	Code no.	Design	Connection		$k_v$ -values (m <sup>3</sup> /h) shown for number of turns										
			Radiator	System	0.25	0.5	0.75	1	1.5	2	2.5	3	3.5	4	$k_{vs}$
RLV DN 15	<b>003L0225</b>	Angle	R $\frac{1}{2}$	Pressfit	0.2	0.4	0.5	0.65	1.0	1.3	1.7	1.9	2.1	2.3	2.5
RLV DN 15	<b>003L0224</b>	Straight			0.2	0.4	0.5	0.65	1.0	1.3	1.7	1.9	2.1	2.3	2.5

**Technical data:** Max. operating pressure: 10 bar, Test pressure: 10 bar, max. water temperature: 90 °C

### Accessories

Produkt	Bestell-Nr.
Fill and drain tap.	<b>003L0152</b>
Manual hand wheel.	<b>013G3300</b>

### Approvals

Danfoss Pressfit valves are tested and approved according to EN 215 (CEN). Pipes compatible with Danfoss pressfit valves are according to EN 10312 (welded stainless steel pipes), EN 1057 (seamless copper pipes) with a minimal wall thickness of 1 mm.

The O-rings used in the Danfoss pressfit valves bodies are according to EN 681.

**Press system**

**Pipes**

Copper and stainless steel pipes which complies to EN 1057 or EN 10312.

**Steel pipes**

Outer diameter and pipe weight according to EN 10312, Table 2 for serie 2 steelpipes. Danfoss recommends a pipe weight of min. 1 mm.

**Carbon steel pipes**

Tubes in unalloyed steel E195(W.nr.1.0034) and E235(W.nr.1.0308) according to EN10305-2 or EN 10305-3 in condition +A or +N.

**Copper pipes**

Outer diameter and wall thickness according to EN 1057, Table 3. Danfoss recommends a minimal wall thickness of 1 mm.

Pipe hardness min. R 290, meaning that only copper pipes in bars are compatible. No internal reinforcement is required.

**Compatibility**

The pressable area of Danfoss Pressfit valves are designed to match a range of commercial press tools and jaws as described in the table. For tools not mentined please check the with the manufacturer.

**Compatible press tools**

Press tools and jaws must be used and serviced as described by their manufacturer, and the actual press operation must be inspected. Danfoss require a minimal press force of 30 kN.

The actual pressing must not be interrupted and the tool should be locked for removal until the pressing has been completed correctly.

The testing of the press points is done according to the manufactures specs.

**Compatible press tools**

- Geberit Mapress: PWH 75, EFP2, ECO1/ACO1, EFP3, AFP3, ACO 3
- REMS: Power-Press E, Power-Press 2000, Power-Press (ACC), Akku-Press (ACC)
- Rothenberger: ROMAX Pressliner, ROMAX Pressliner ECO, ROMAX AC ECO
- SANHA: ECO201, ACO201, ACO3, ECO301
- Viega: PT3-EH, PT3-AH, Picco, Typ 2
- Novopress: AFP 101
- RIDGID: CT-400, 320-E
- Klauke: UAP2, UNP2, UP2EL-14

**Compatible press jaws**

- Mapress Geberit: Press jaws15 mm (90532)
- REMS: V15 (570115), M15 (570110), SA15 (570935)
- Rothenberger: SV 15 mm (1.5212X), M 15 mm (1.5102X)
- SANHA: Standard, 15 mm (1692015, 1695815)
- Viega: PT2 15mm (Modell 2299.9, Typ 461 898)
- Novopress: M 15
- RIDGID: ProPress 15 mm (16958)
- Klauke: KSP3 M15 mm, KSP4 V15 mm

***With system under pressure all pressfit connections should be inspected. Even if no leakage is seen the connection should be checked.***

Fitting

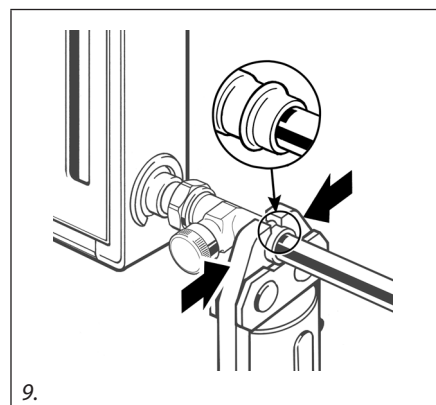
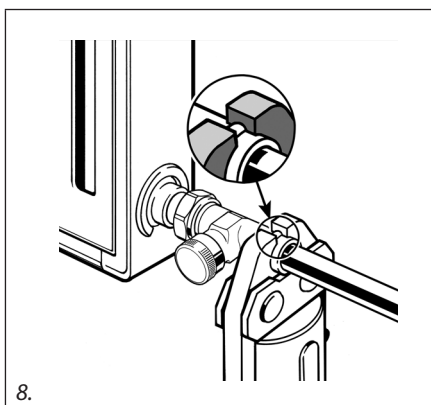
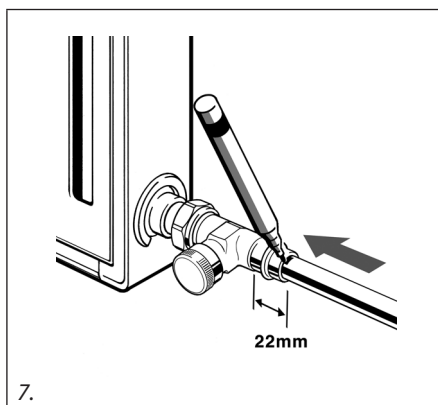
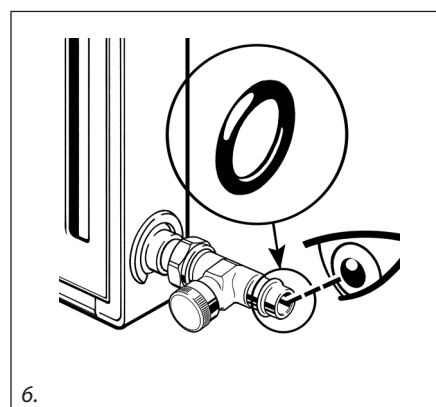
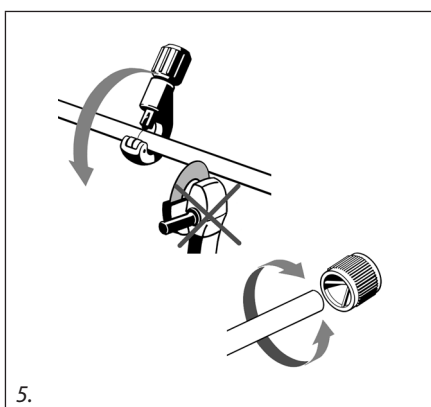
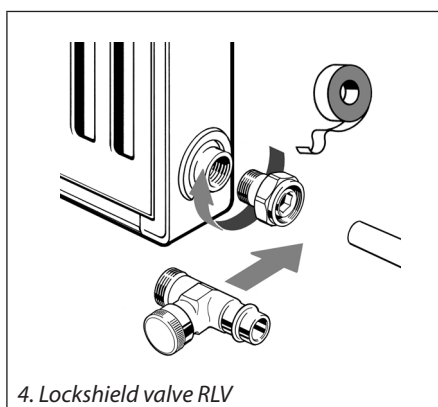
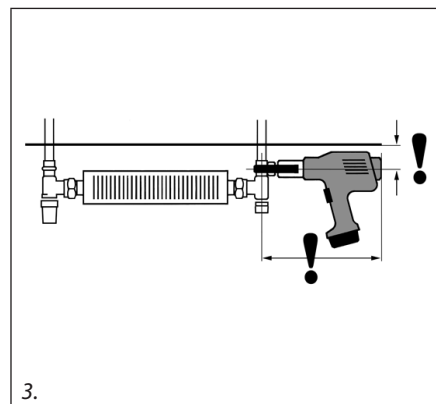
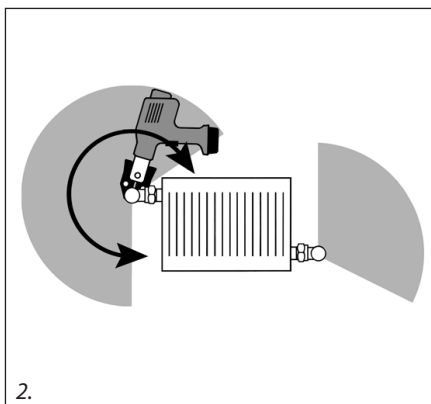
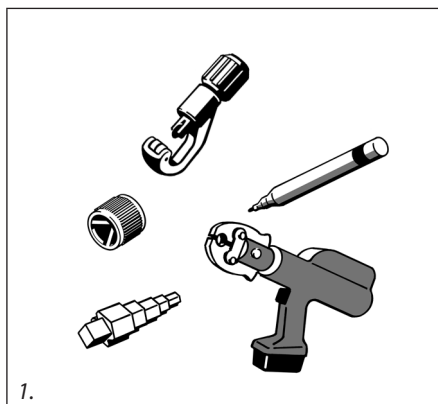

**Draining and filling the radiator**

RLV is intended for mounting on the outlet of the radiator. To enable subsequent draining of the radiator water, the lockshield valve should be mounted with its cover pointing out from the wall.

Fitting the drain tap:

1. Shut off the radiator inlet valve. As a safety precaution the thermostatic operator should be replaced by a Danfoss manual shut off handle, code no. 013G3300.
2. Remove the cover and shut off the valve.
3. Mount the drain tap and align the drain branch, which can revolve in any direction.
4. Open valve for draining by means of a spanner (KW9)

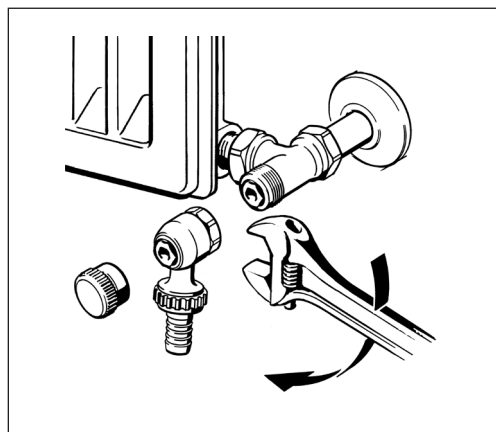

**Valve settings**

Factory setting is fully open valve.  
Max. water flow may be reduced:

- A Close the valve by means of a 6 mm Allen key.
- B Regulate the water flow by opening the valve. The capacity diagramme below shows the water flow at 1/4 - 4 turns and for fully open valve ( $k_{vs}$ ).

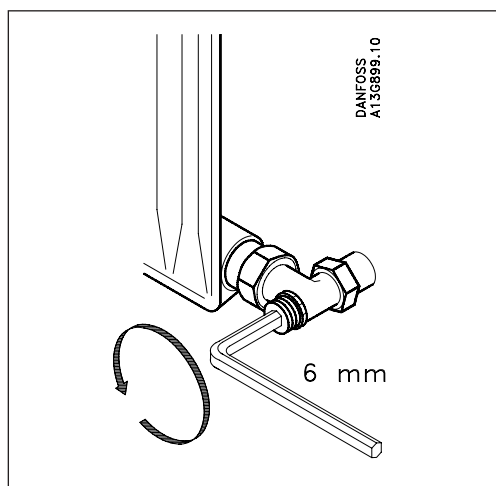

**Capacity**

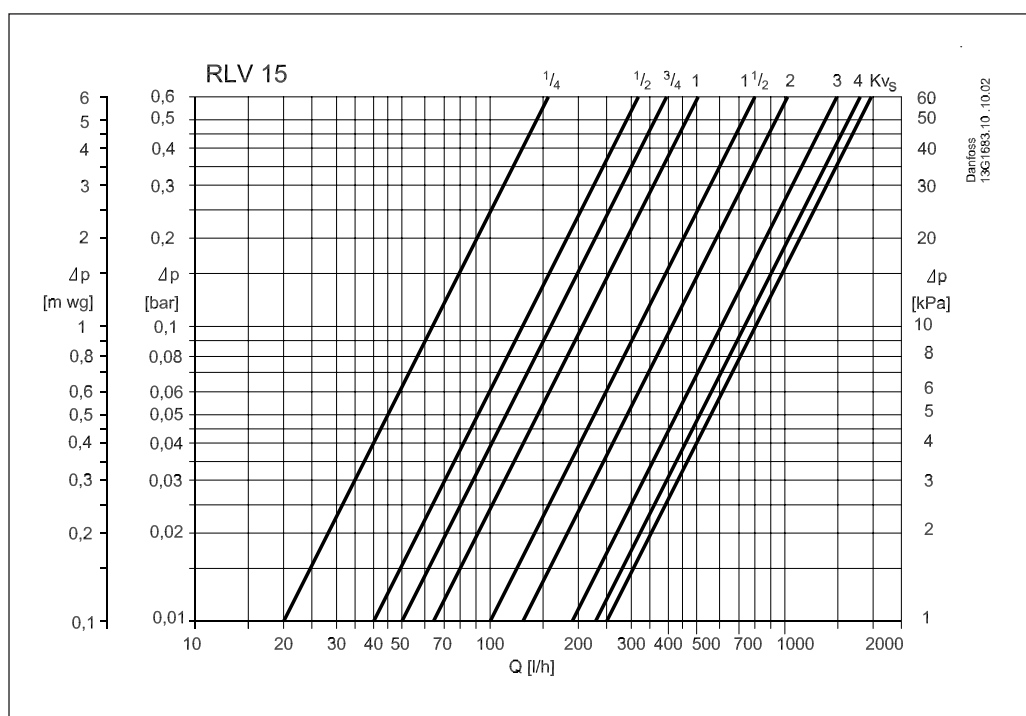

Design

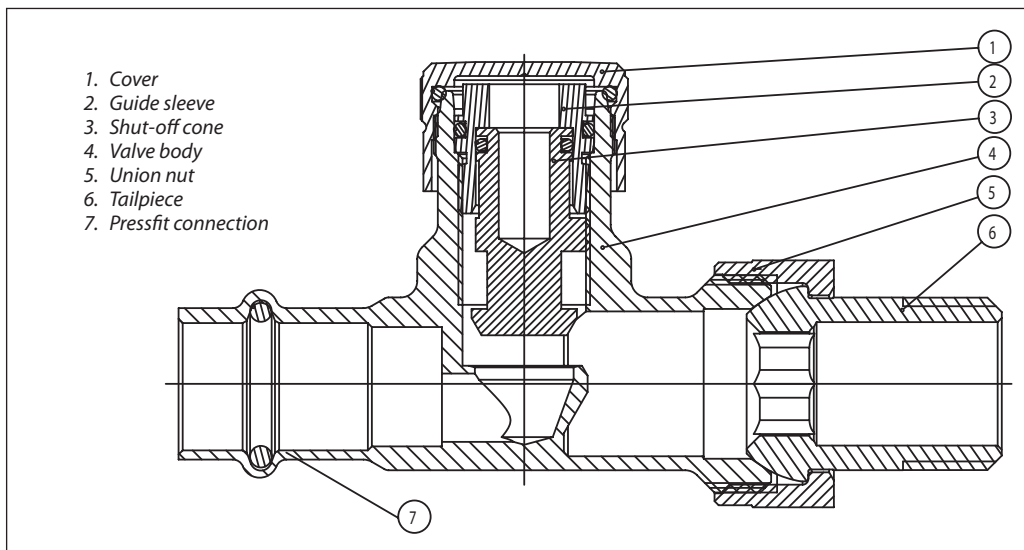

Materials in contact with water

Valve body	Ms 58
O-ring	EPDM
Other metal parts	Ms 58

Dimensions

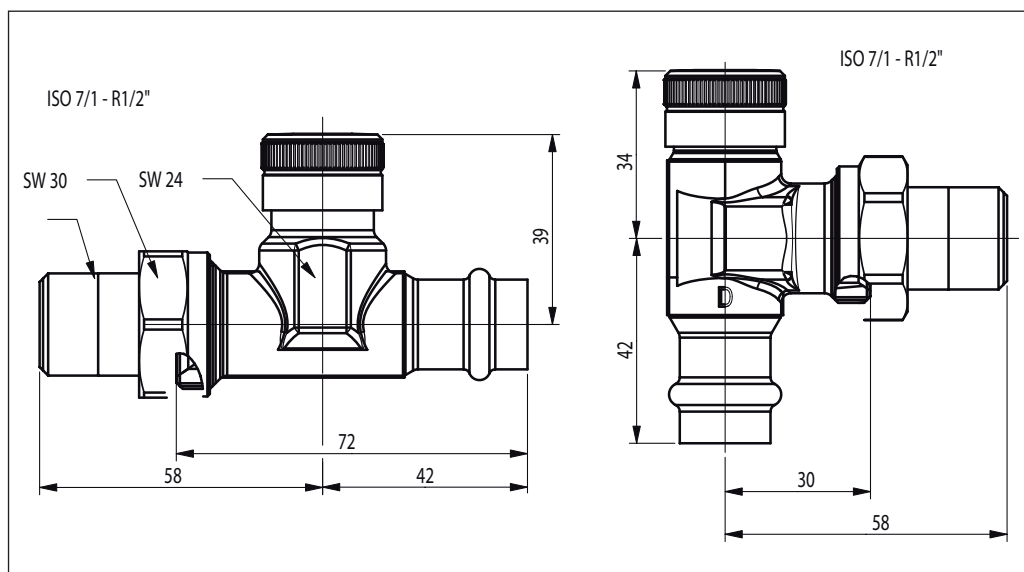

---

Danfoss can accept no responsibility for possible errors in catalogues, brochures and other printed material. Danfoss reserves the right to alter its products without notice. This also applies to products already on order provided that such alterations can be made without subsequential changes being necessary in specifications already agreed. All trademarks in this material are property of the respective companies. Danfoss and the Danfoss logotype are trademarks of Danfoss A/S. All rights reserved.

---

