

Data sheet

Manual presetting valve MSV-F2, PN 16/25, DN 15 - 400

Description

MSV-F2 DN 15-150



MSV-F2 DN 200-400



MSV-F2 valves are manual presetting valves. They are used for balancing the flow in heating and cooling installations.

The valves have position indicator and stroke limiter as standard. Hood of spindle is integrated with stroke limiter.

Setting can be locked. Valve characteristics are set up in measuring device PFM 5000.

Valves are free of asbestos.

Shut-off function.

Main data:

- DN 15 - 400
- PN 16:
 - Flow temperature: -10 °C...130 °C
- PN 25:
 - Flow temperature: -10 °C...150 °C
- Valves are mounted on flow or return pipe.

Application

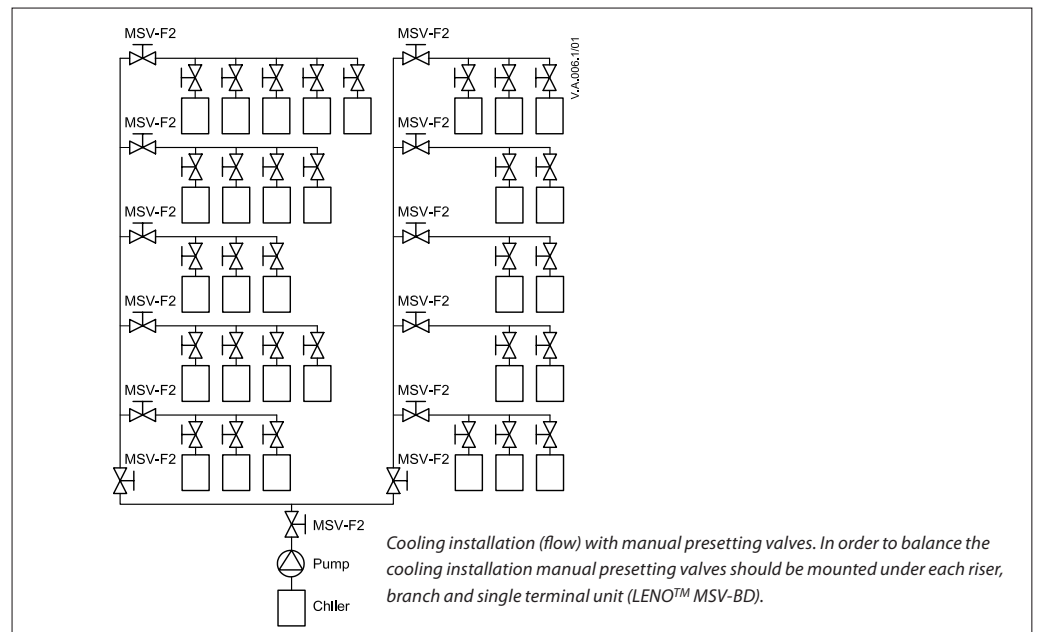

In constant flow installations MSV valves keeps constant pressure drop. Its value may be set on several levels depending on presetting.

Ordering

MSV-F2 valves - PN 16

Picture	DN ¹⁾ (mm)	k _{vs} (m ³ /h)	T _{max.} (°C)	PN (bar)	Code No. (with needle measuring nipples)
	15	3.1	130	16	003Z1085
	20	6.3			003Z1086
	25	9.0			003Z1087
	32	15.5			003Z1088
	40	32.3			003Z1089
	50	53.8			003Z1061
	65	93.4			003Z1062
	80	122.3			003Z1063
	100	200.0			003Z1064
	125	304.4			003Z1065
	150	400.8			003Z1066
	200	685.6			003Z1067
	250	952.3			003Z1068
	300	1380.2			003Z1069
	350	2046.1			003Z1090
	400	2584.6			003Z1091

MSV-F2 valves - PN 25

Picture	DN ¹⁾ (mm)	k _{vs} (m ³ /h)	T _{max.} (°C)	PN (bar)	Code No. (with needle measuring nipples)
	15	3.1	150	25	003Z1092
	20	6.3			003Z1093
	25	9.0			003Z1094
	32	15.5			003Z1095
	40	32.3			003Z1096
	50	53.8			003Z1070
	65	93.4			003Z1071
	80	122.3			003Z1072
	100	200.0			003Z1073
	125	304.4			003Z1074
	150	400.8			003Z1075
	200	685.6			003Z1076
	250	952.3			003Z1077
	300	1380.2			003Z1078
	350	2046.1			003Z1097
	400	2584.6			003Z1098

¹⁾ Flange valves dimension DN 15-40, 350 and 400 available on request.

Accessories

Type	Code No.
Rectus test plugs, 2 pcs.	003Z0108
Standard test plugs with O-ring, 2 pcs.	003Z0104
Extension piece for test plugs 45 mm, 2 pcs.	003Z0103
Extended test plugs mounted under pressure, 2 pcs.	003Z3946
PFM 5000 measuring device	003L8334

Type	Code No.	
Hand-wheel	DN 15 - 50	003Z0179
	DN 65 - 150	003Z0180
	DN 200	003Z0181
	DN 250 - 300	003Z0182
	DN 350 - 400	003Z0183

Technical data
MSV-F2 valves - PN 16

Nominal diameter	DN	15	20	25	32	40	50	65	80	100	125	150	200	250	300	350	400
k_{vs}	(m ³ /h)	3.1	6.3	9.0	15.5	32.3	53.8	93.4	122.3	200.0	304.4	400.8	685.6	952.3	1380.2	2046.1	2584.6
Nominal pressure	(bar)	16															
Max. pressure drop	(bar)	1.5															
Leakage rate		Grade A; According to ISO5208, Table 5 (No visible leakage)															
Flow medium		Water and water mixtures with secondary coolants (like glycols)* for closed heating and cooling systems															
Max. flow temperature	(°C)	130															
Connections		Flanges according to EN 1092-2															
Weight	(kg)	2.3	2.9	3.8	5.6	7.2	9.4	17	21	32	43	56	231	354	497	747	890
Material of body		Cast iron EN-GJL 250 (GG 25)															
Seat sealing		EPDM															
Material of cone		CW602N						CuSn5Zn5Pb5						Casted stainless steel			

* Please verify compability between materials and secondary coolants with supplier.

MSV-F2 valves - PN 25

Nominal diameter	DN	15	20	25	32	40	50	65	80	100	125	150	200	250	300	350	400
k_{vs}	(m ³ /h)	3.1	6.3	9.0	15.5	32.3	53.8	93.4	122.3	200.0	304.4	400.8	685.6	952.3	1380.2	2046.1	2584.6
Nominal pressure	(bar)	25															
Max. pressure drop	(bar)	2.0															
Leakage rate		Grade A; According to ISO5208, Table 5 (No visible leakage)															
Flow medium		Water and water mixtures with secondary coolants (like glycols)* for closed heating and cooling systems															
Max. flow temperature	(°C)	150															
Connections		Flanges according to EN 1092-2															
Weight	(kg)	2.3	3.0	3.8	5.8	7.2	9.4	17	21	33	43	56	228	345	488	748	900
Material of body		Ductile iron EN-GJS 400-15 (GGG-40)															
Seat sealing		EPDM															
Material of cone		CW602N						CuSn5Zn5Pb5						Casted stainless steel			

* Please verify compability between materials and secondary coolants with supplier.

Pressure-temperature classification (flanges according to EN 1092-2)

Material	PN	Temperature			
		-10 °C	120 °C	130 °C	150 °C
EN-GJL 250 (MSV-F2 DN 15-150)	16	16 bar	16 bar	15.5 bar	-
EN-GJL 250 (MSV-F2 DN 200-400)	16	16 bar	16 bar	15.5 bar	-
EN-GJS 400-15 (MSV-F2 DN 15-150)	25	25 bar	25 bar	-	24.3 bar
EN-GJS 400-15 (MSV-F2 DN 200-400)	25	25 bar	25 bar	-	24.3 bar

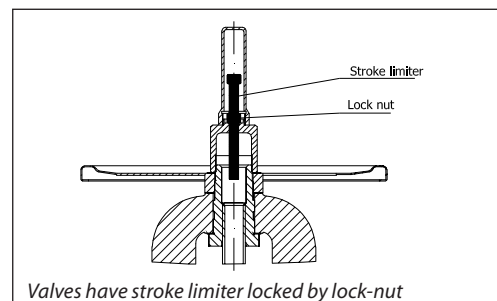
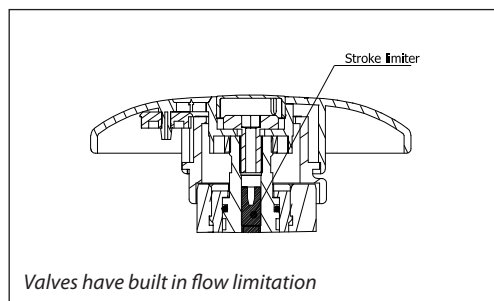

Design

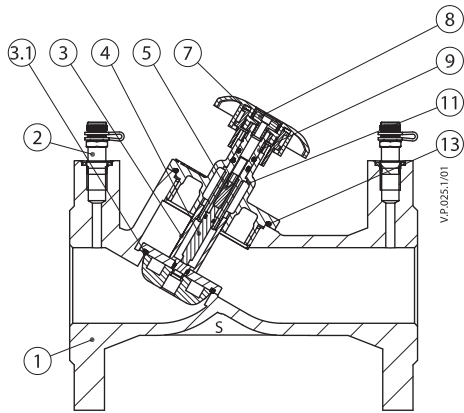

MSV-F2 DN 15 - 50

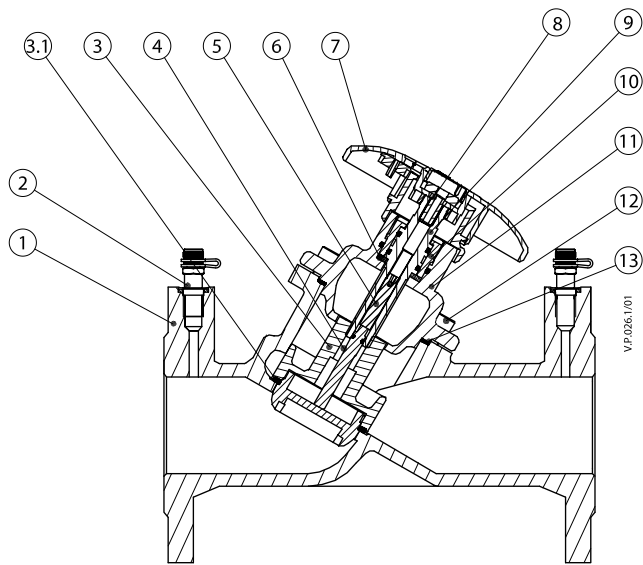

MSV-F2 DN 65

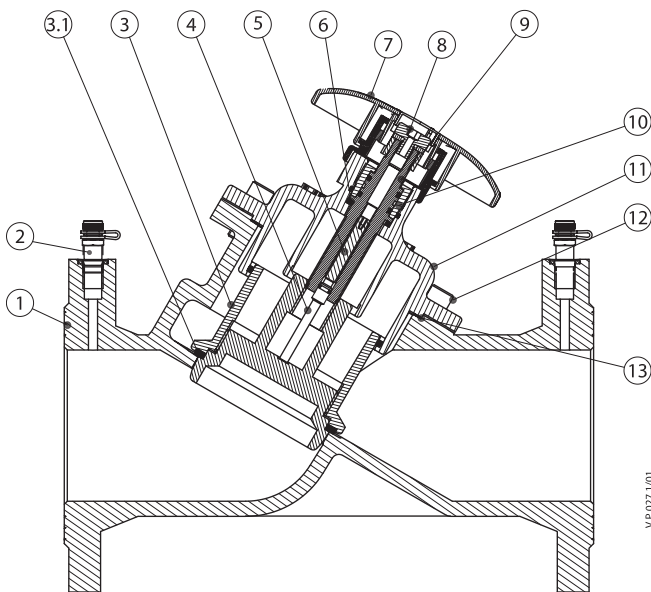

MSV-F2 DN 80 - 150

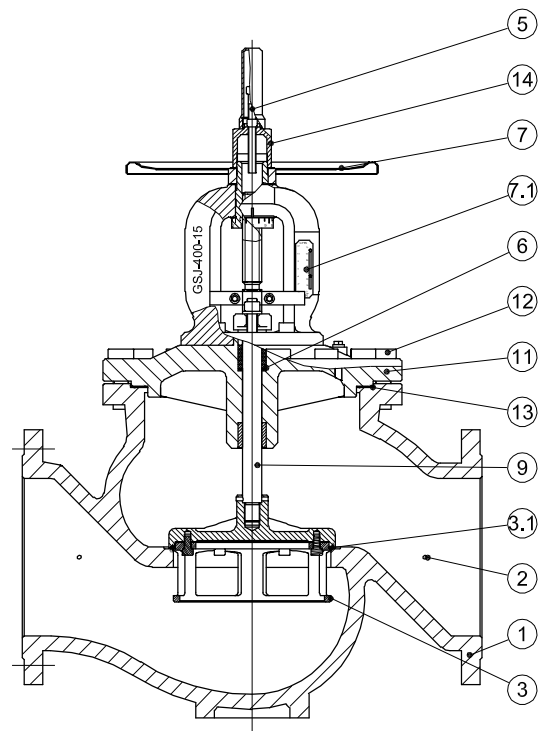

MSV-F2 DN 200 - 400

- 1 Body EN-GJL250
- 2 Nipple
- 3 Valve cone
- 3.1 Seat soft sealing
- 4 Rod
- 5 Stroke limiter/Allen screw
- 6 Gasket
- 7 Handwheel with digital display
 - DN 15 - 150 plastic
 - DN 200 - 400 metal

- 7.1 Display
- 8 Fixed screw
- 9 Spindle
- 10 Stuffing box
- 11 Bonnet
- 12 Allen screw /Hexagon screw
- 13 Flat gasket
- 14 Hood with stroke

Setting

Ethylenglycol correction factor

Formula: $C_2H_6O_2$
 Density at 20 °C: $\rho_{water} = 1 \text{ kg/dm}^3$
 $\rho_{glycol} = 1.338 \text{ kg/dm}^3$

$$Q_{corr.} = \frac{Q_{water}}{\sqrt{\text{Share of water} \times \rho_{water} + \text{Share of glycol} \times \rho_{glycol}}}$$

Ethylenglycol part xg (%)	0	10	20	30	40	50	60	70	80	90	100
Correction factor	1.0	0.983	0.968	0.953	0.939	0.925	0.912	0.899	0.887	0.876	0.864

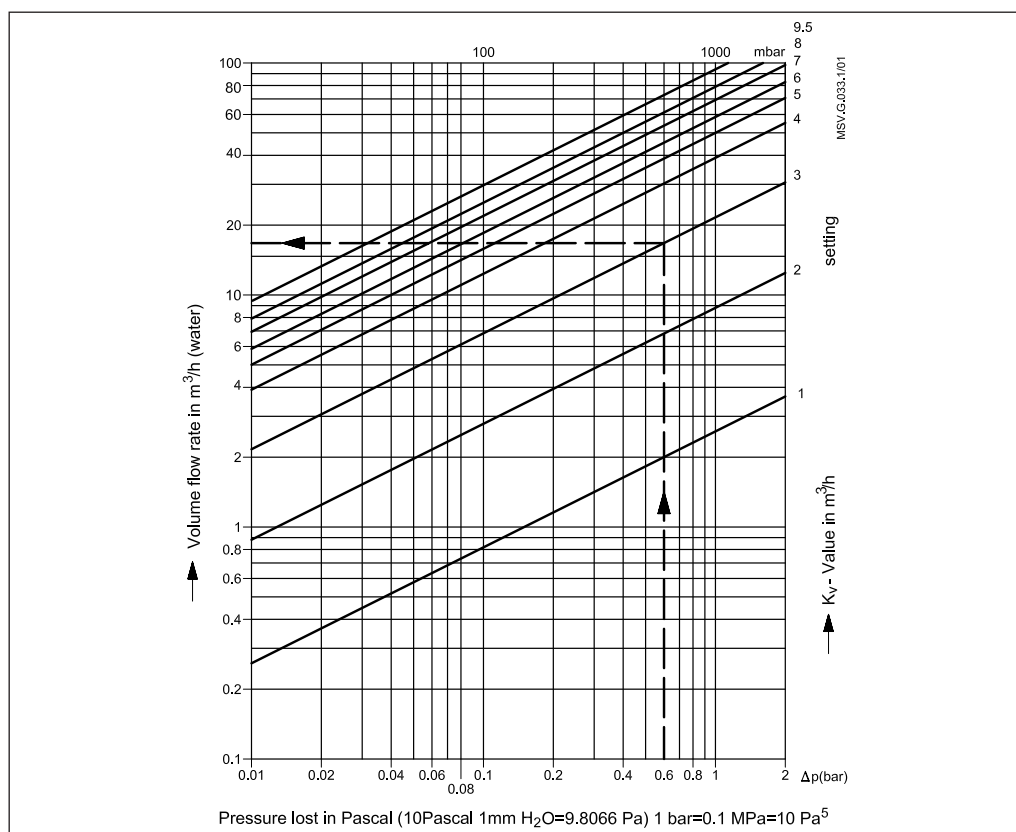

MSV-F2 DN 65
 $\Delta p = 0.6 \text{ bar}$
 Hand wheel setting: 3.0
 Flow: $16.8 \text{ m}^3/\text{h}$
 30% glycol
 $Q_{corr.} = 16.8 \text{ m}^3/\text{h} \times 0.953 = 16.0 \text{ m}^3/\text{h}$
 It refers to all types of valves.

Installation

Always install the valve with the arrow on the body in the same direction as the flow. In order to avoid turbulence, which will affect the measuring accuracy, it is recommended to have a straight length of pipe up and down stream from the valve as shown (D - diameter of pipe).

The influence of turbulence, if our recommendations are not adhered to, can influence the flow up to 20%.

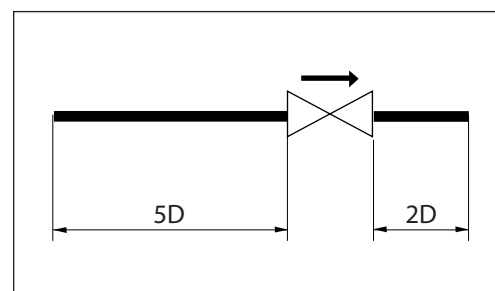

Sizing

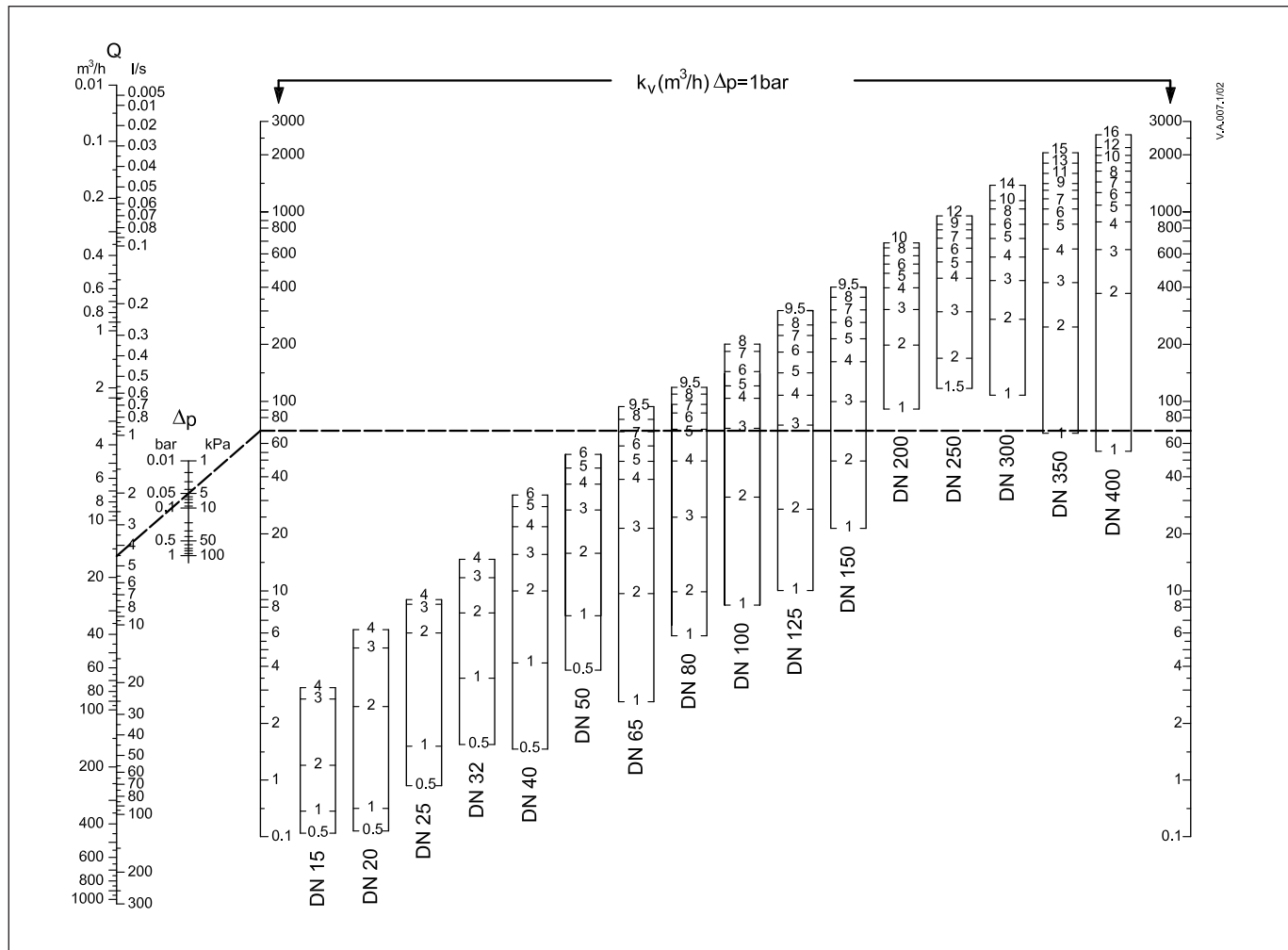

Example:
 MSV-F2 DN 65
 Q = 16 m³/h
 Δp = 5 kPa

Calculation of setting for valve:
 In the diagram a straight line connecting the bars for flow 16 m³/h, differential pressure 5 kPa and k_v value shows the relationship between these three variables.

A horizontal line from intersection with the k_v bar shows the presetting value for each valve size.

Result:
 presetting 7.0

Flow diagrams

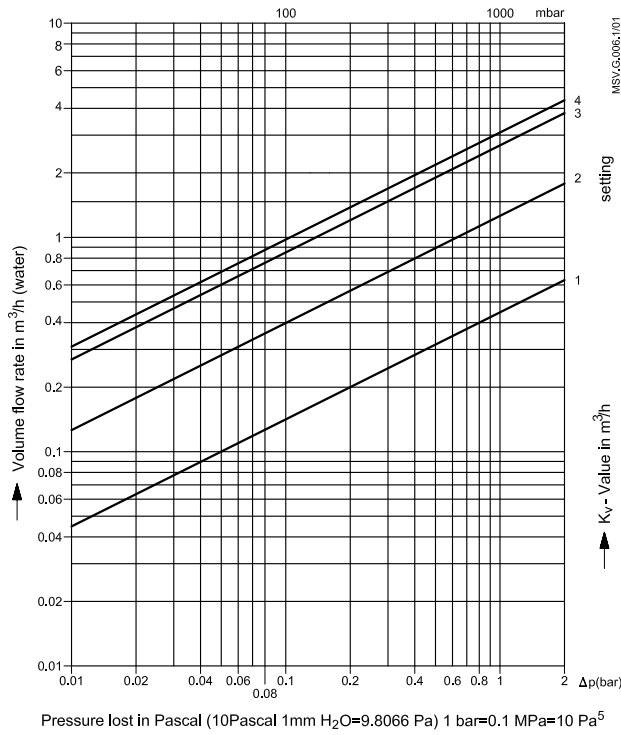

DN 15 / PN 16 / PN 25

Setting	k _v -value
1	0.45
2	1.26
3	2.73
4	3.09

Max. permissible differential pressure in throttling function 1.5/2.0 bar.
 Max. permissible flow speed: ≤ 4 m/s
 Condition:
 • The flow must be free of cavitation.

Flow characteristic

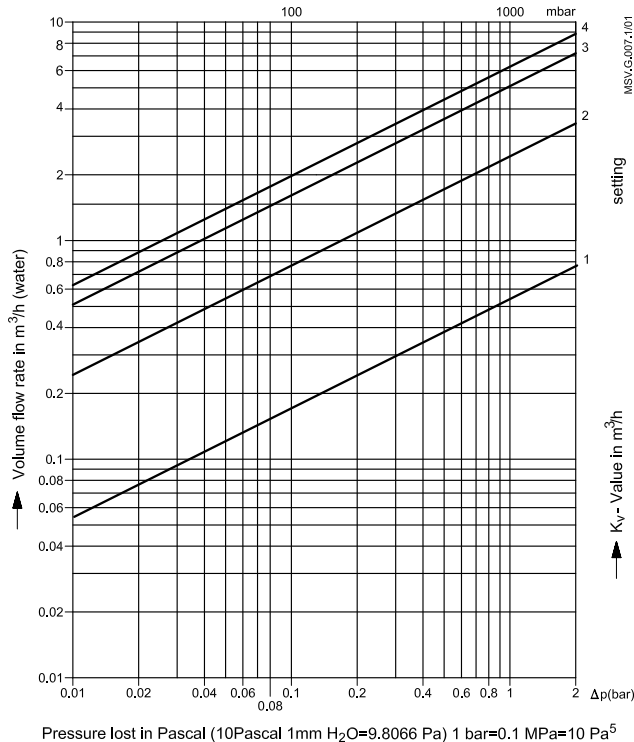
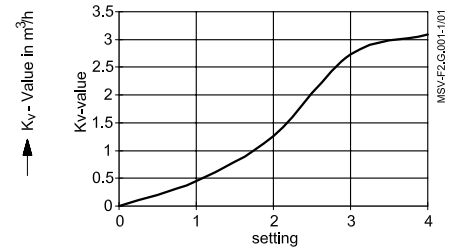

DN 20 / PN 16 / PN 25

Setting	k _v -value
1	0.54
2	2.48
3	5.11
4	6.26

Max. permissible differential pressure in throttling function 1.5/2.0 bar.
 Max. permissible flow speed: ≤ 4 m/s
 Condition:
 • The flow must be free of cavitation.

Flow characteristic

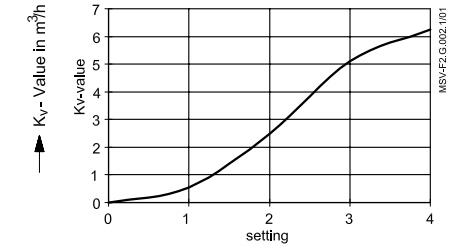

Flow diagrams (continued)

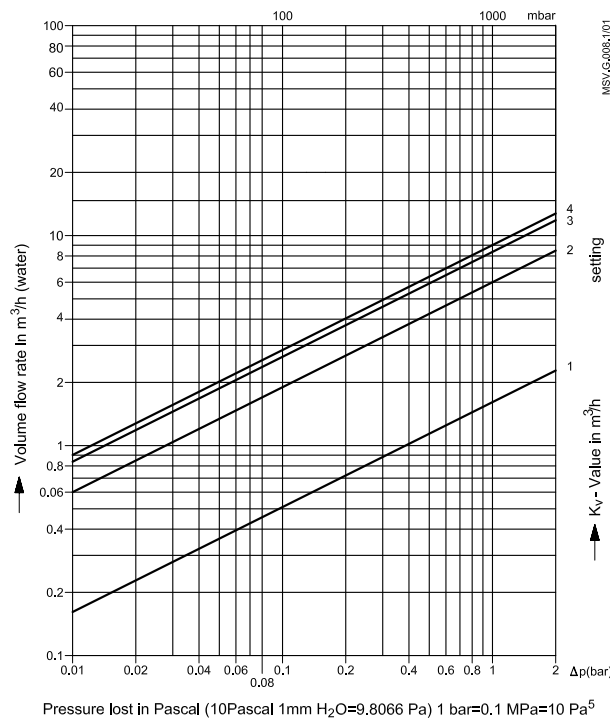

DN 25 / PN 16 / PN 25

Setting	k _v -value
1	1.61
2	6.0
3	8.38
4	9.01

Max. permissible differential pressure in throttling function 1.5/2.0 bar.

Max. permissible flow speed: ≤ 4 m/s

Condition:

- The flow must be free of cavitation.

Flow characteristic

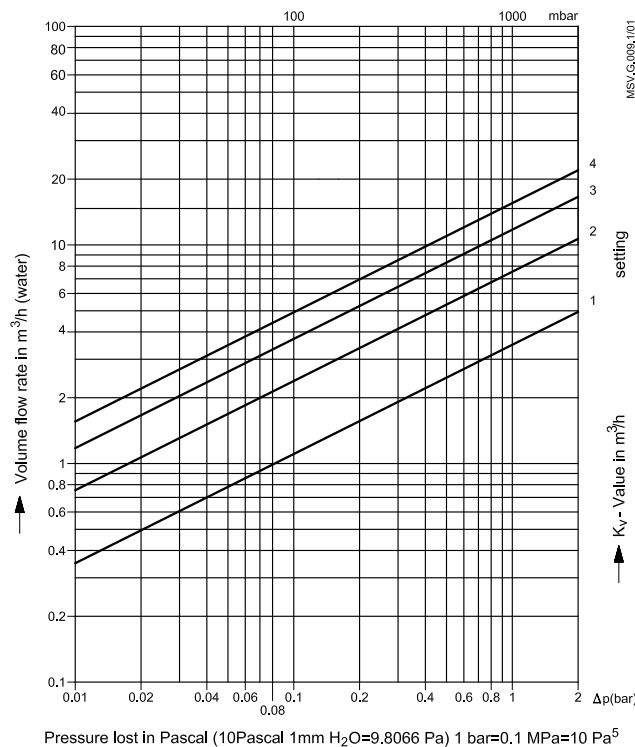
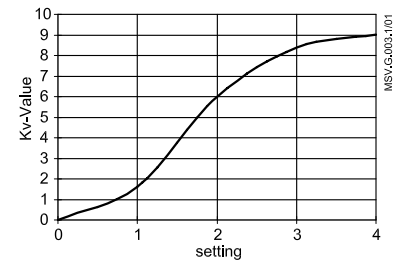

DN 32 / PN 16 / PN 25

Setting	k _v -value
1	3.53
2	7.56
3	12.32
4	15.54

Max. permissible differential pressure in throttling function 1.5/2.0 bar.

Max. permissible flow speed: ≤ 4 m/s

Condition:

- The flow must be free of cavitation.

Flow characteristic

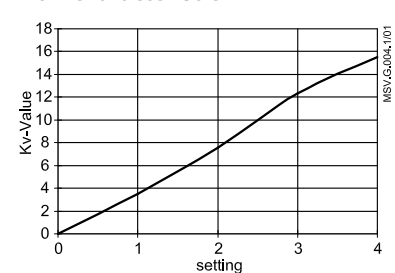

Flow diagrams (continued)

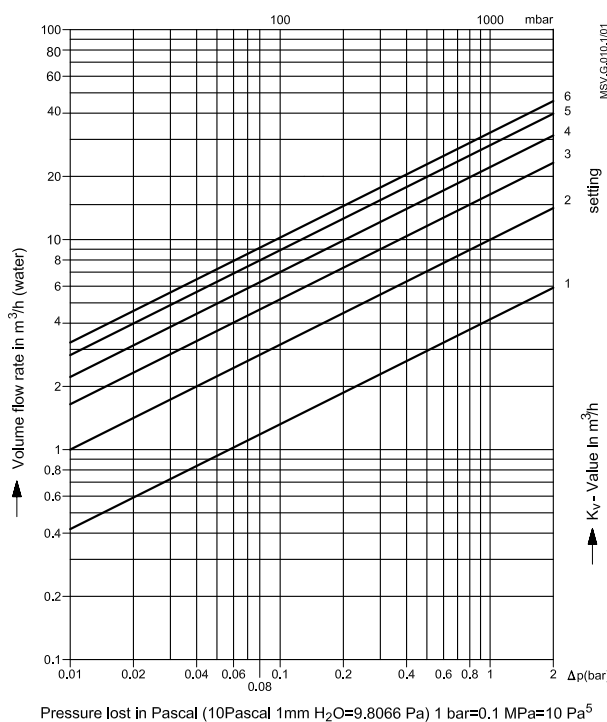

DN 40 / PN 16 / PN 25

Setting	k _v -value
1	4.19
2	9.98
3	16.42
4	22.13
5	28.14
6	32.31

Max. permissible differential pressure in throttling function 1.5/2.0 bar.

Max. permissible flow speed: ≤ 4 m/s

Condition:

- The flow must be free of cavitation.

Flow characteristic

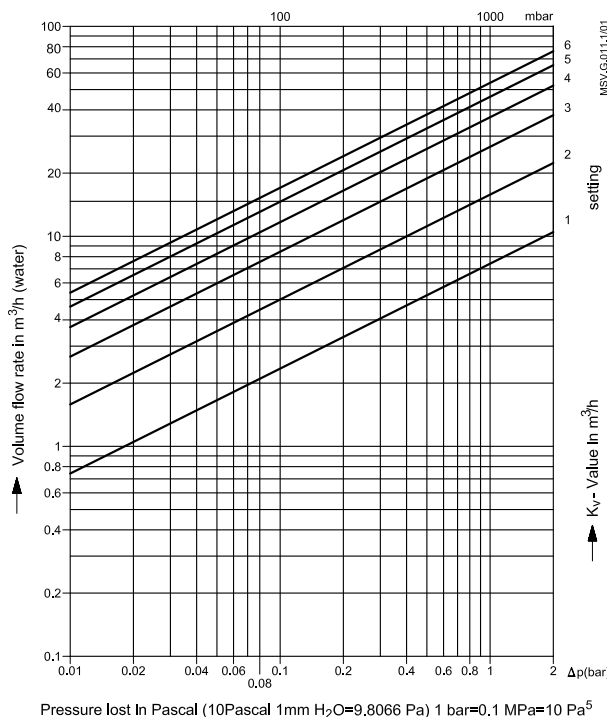
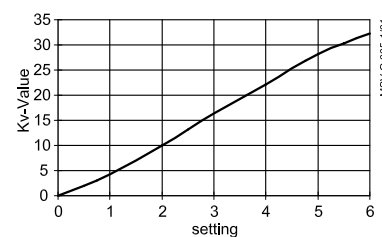

DN 50 / PN 16 / PN 25

Setting	k _v -value
1	7.4
2	15.8
3	26.7
4	36.9
5	46.2
6	53.8

Max. permissible differential pressure in throttling function 1.5/2.0 bar.

Max. permissible flow speed: ≤ 4 m/s

Condition:

- The flow must be free of cavitation.

Flow characteristic

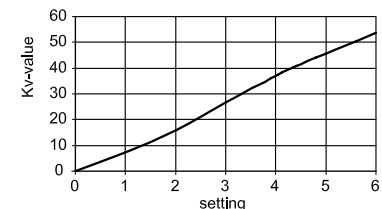

Flow diagrams (continued)

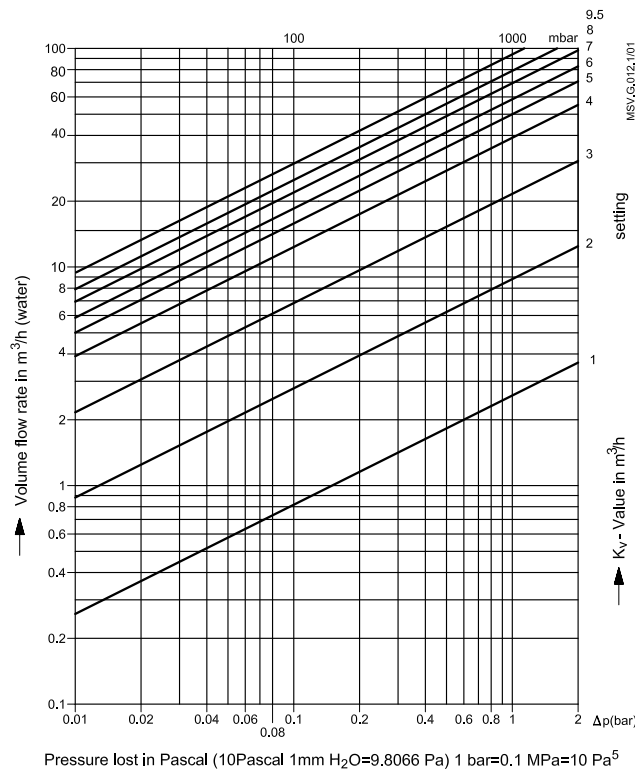

DN 65 / PN 16 / PN 25

Setting	k _v -value
1	2.6
2	8.8
3	21.6
4	39.0
5	49.8
6	58.5
7	69.3
8	79.0
9	87.8
9.5	93.4

Max. permissible differential pressure in throttling function 1.5/2.0 bar.
 Max. permissible flow speed: ≤ 4 m/s
 Condition:

- The flow must be free of cavitation.

Flow characteristic

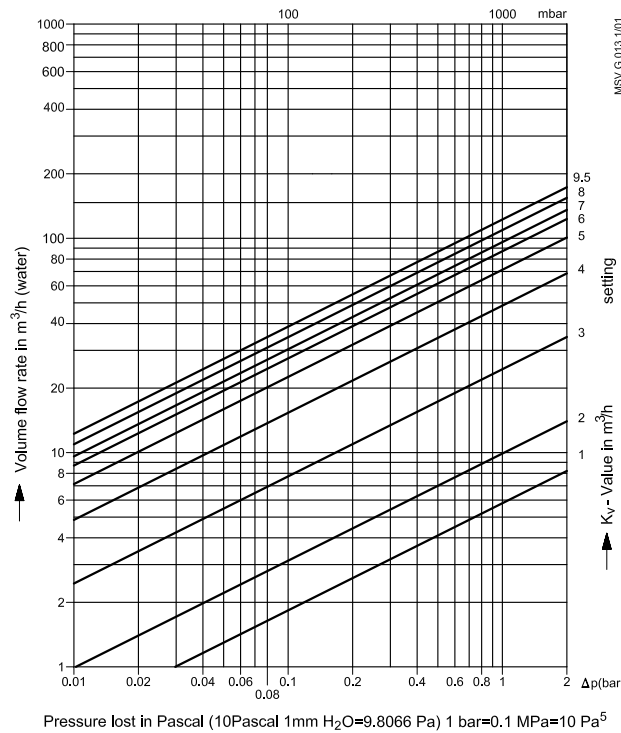
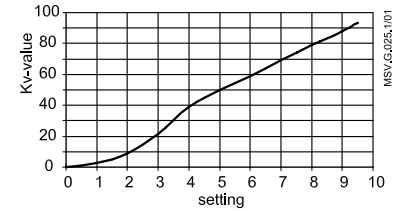

DN 80 / PN 16 / PN 25

Setting	k _v -value
1	5.8
2	9.9
3	24.5
4	48.5
5	71.3
6	87.0
7	96.4
8	109.3
9.5	122.3

Max. permissible differential pressure in throttling function 1.5/2.0 bar.
 Max. permissible flow speed: ≤ 4 m/s
 Condition:

- The flow must be free of cavitation.

Flow characteristic

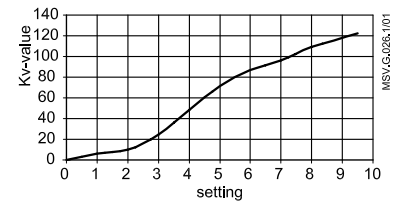

Flow diagrams (continued)

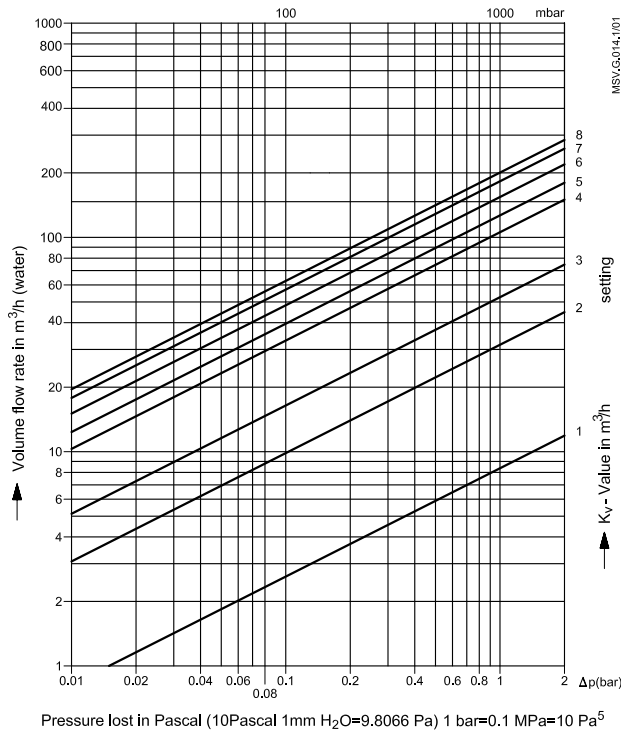

DN 100 / PN 16 / PN 25

Setting	k _v -value
1	8.3
2	32.4
3	72.9
4	107.2
5	128.2
6	152.8
7	180.0
8	200.0

Max. permissible differential pressure in throttling function 1.5/2.0 bar.

Max. permissible flow speed: ≤ 4 m/s

Condition:

- The flow must be free of cavitation.

Flow characteristic

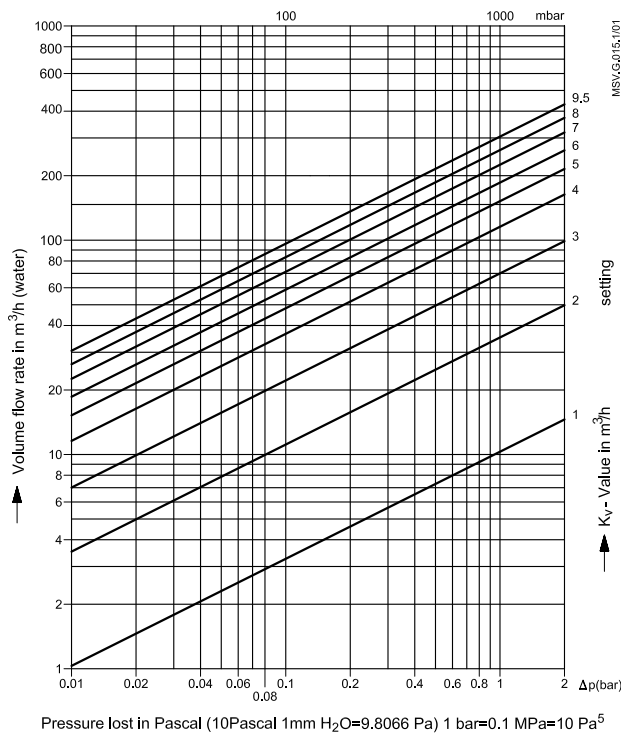
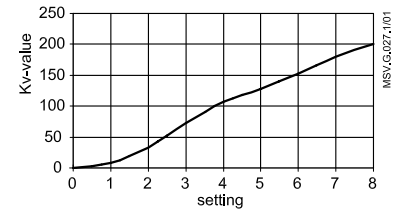

DN 125 / PN 16 / PN 25

Setting	k _v -value
1	10.3
2	35.4
3	73.0
4	114.9
5	150.5
6	185.2
7	225.1
8	261.1
9	294.2
9.5	304.4

Max. permissible differential pressure in throttling function 1.5/2.0 bar.

Max. permissible flow speed: ≤ 4 m/s

Condition:

- The flow must be free of cavitation.

Flow characteristic

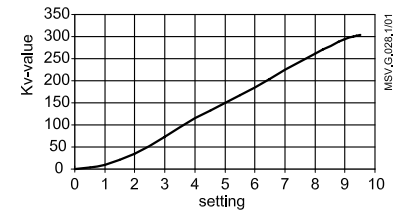

Flow diagrams (continued)

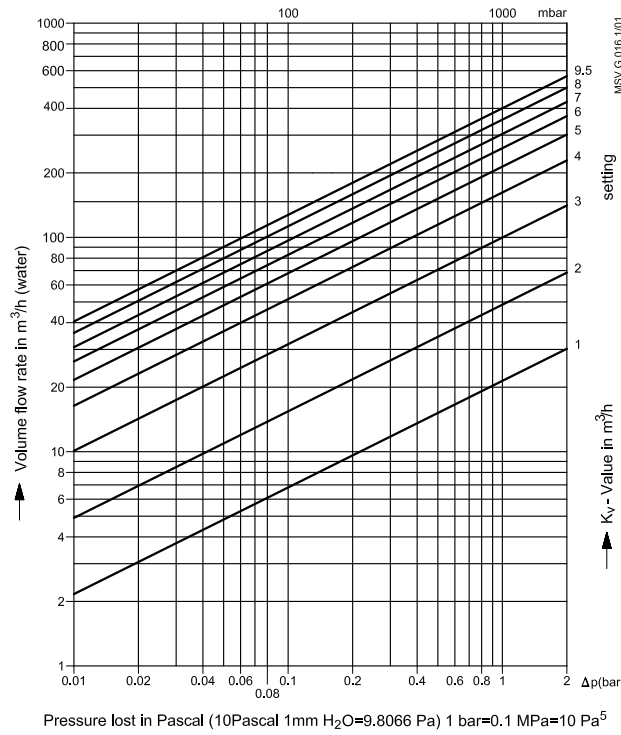

DN 150 / PN 16 / PN 25

Setting	k _v -value
1	21.4
2	48.5
3	99.8
4	162.0
5	214.0
6	260.9
7	304.1
8	354.6
9.5	400.8

Max. permissible differential pressure in throttling function 1.5/2.0 bar.
 Max. permissible flow speed: ≤ 4 m/s
 Condition:
 • The flow must be free of cavitation.

Flow characteristic

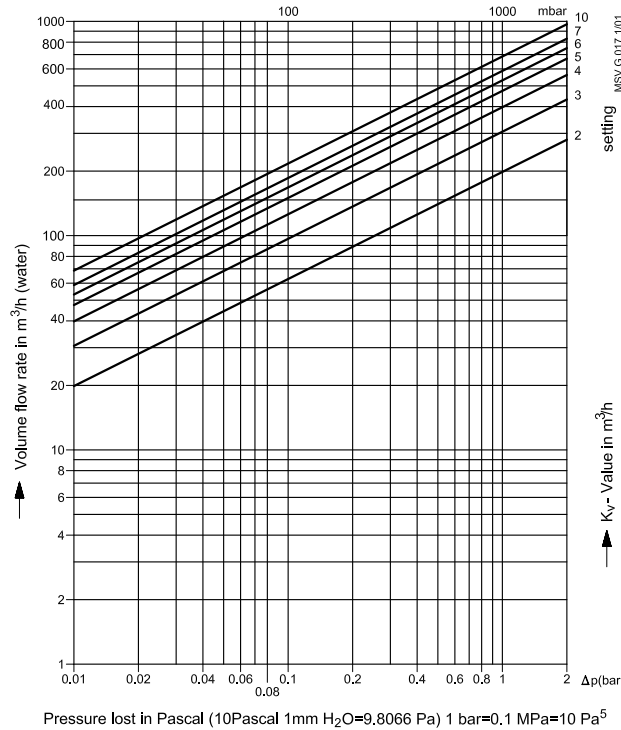
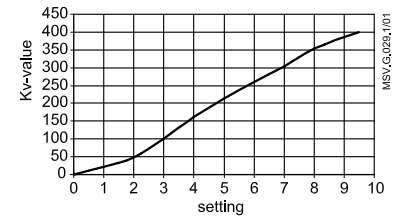

DN 200 / PN 16 / PN 25

Setting	k _v -value
2	198.2
3	305.3
4	397.5
5	474.0
6	530.4
7	586.8
8	645.9
10	685.6

Max. permissible differential pressure in throttling function 1.5/2.0 bar.
 Max. permissible flow speed: ≤ 4 m/s
 Condition:
 • The flow must be free of cavitation.

Flow characteristic

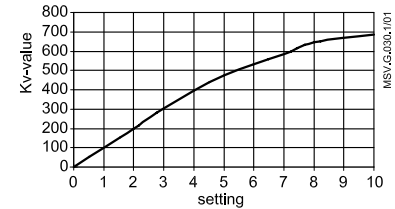

Flow diagrams (continued)

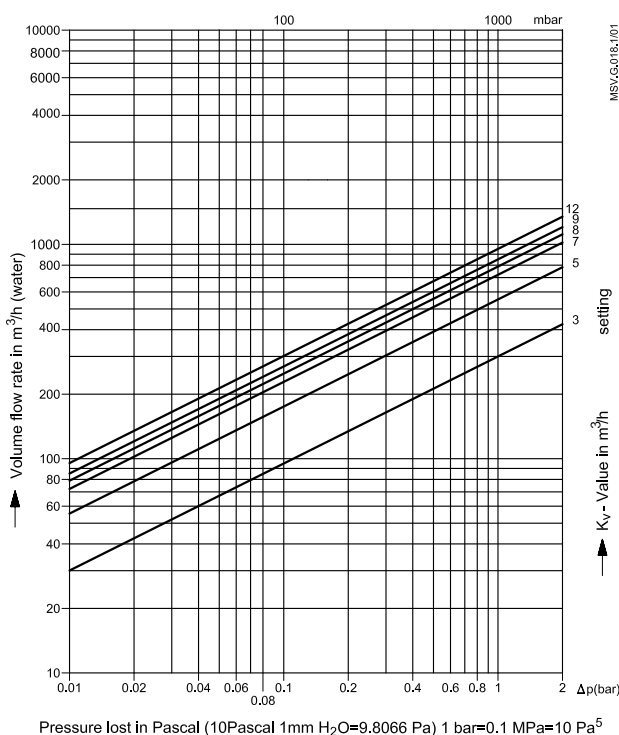

DN 250 / PN 16 / PN 25

Setting	k _v -value
3	299.4
5	553.1
7	721.2
8	788.1
9	851.1
10	926.1
12	952.3

Max. permissible differential pressure in throttling function 1.5/2.0 bar.
 Max. permissible flow speed: ≤ 4 m/s
 Condition:
 • The flow must be free of cavitation.

Flow characteristic

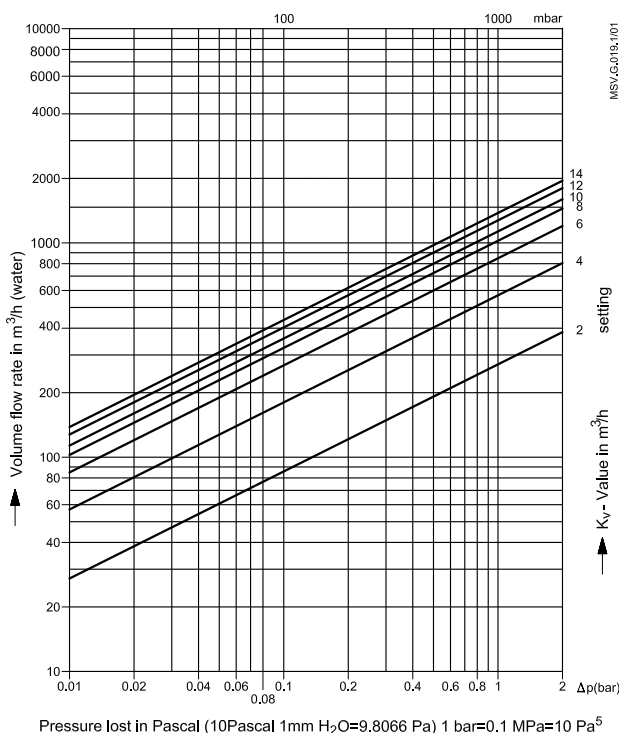
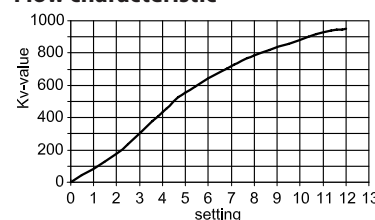

DN 300 / PN 16 / PN 25

Setting	k _v -value
2	270.9
4	575.8
6	856.0
8	1035.9
10	1142.8
12	1273.7
14	1380.2

Max. permissible differential pressure in throttling function 1.5/2.0 bar.
 Max. permissible flow speed: ≤ 4 m/s
 Condition:
 • The flow must be free of cavitation.

Flow characteristic

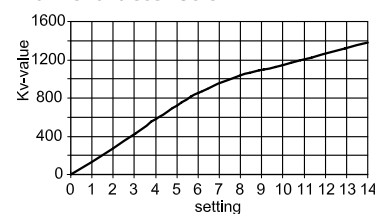

Flow diagrams (continued)

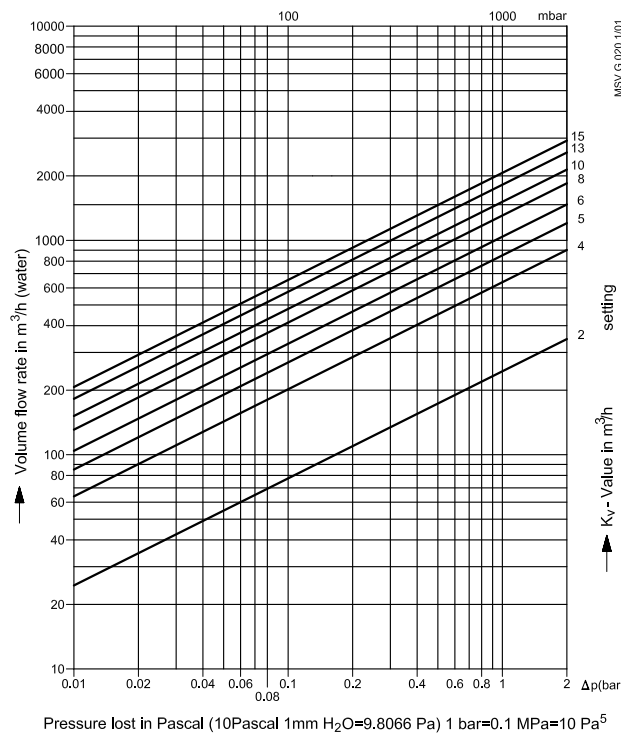

DN 350 / PN 16 / PN 25

Setting	k _v -value
2	249.06
4	634.4
5	844.72
6	1041.93
8	1369.45
10	1580.67
13	1844.74
15	2046.14

Max. permissible differential pressure in throttling function 1.5/2.0 bar.
 Max. permissible flow speed: ≤ 4 m/s
 Condition:
 • The flow must be free of cavitation.

Flow characteristic

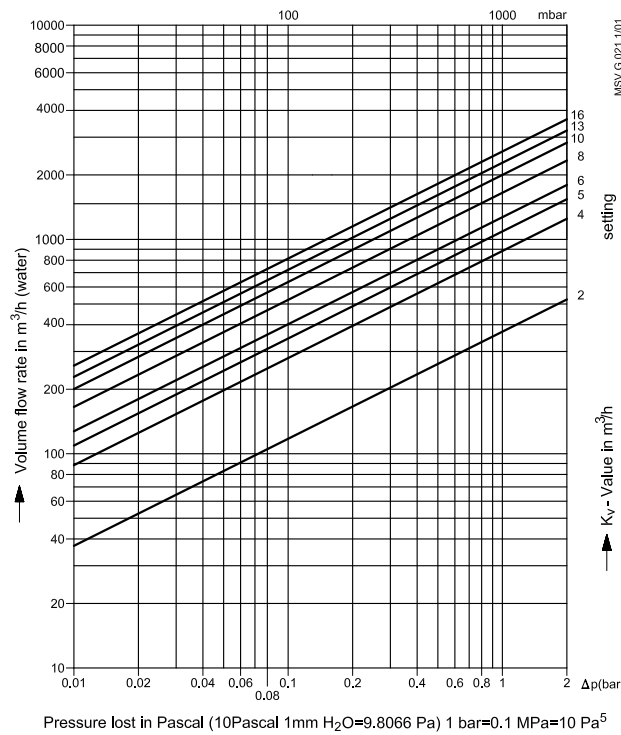
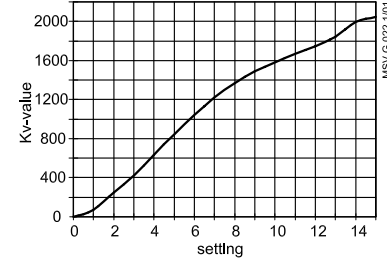

DN 400 / PN 16 / PN 25

Setting	k _v -value
2	371.75
4	875.26
5	1109.31
6	1328.86
8	1705.24
10	1980.56
13	2287.81
16	2584.95

Max. permissible differential pressure in throttling function 1.5/2.0 bar.
 Max. permissible flow speed: ≤ 4 m/s
 Condition:
 • The flow must be free of cavitation.

Flow characteristic

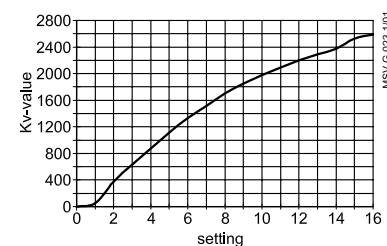

Dimensions

