

Data sheet

Pressure independent balancing and control valve AB-QM DN 10 - 100

Description

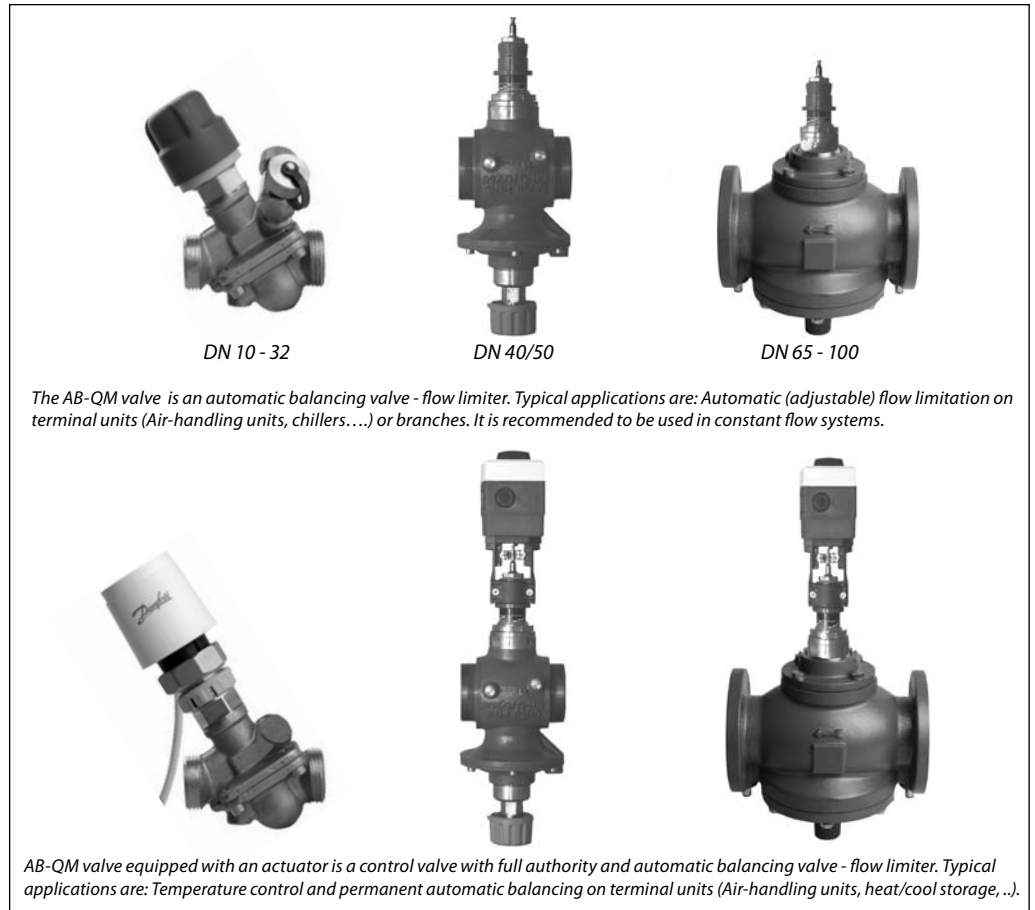

Benefits:

- Exact and pressure independent flow limitation allows no overflows at partial conditions to keep temperature difference over terminal unit as high as designed
- The AB-QM is able to control the temperature at low loads and is equally stable all through the range. All changes in the available differential pressure are corrected by the pressure controller. Therefore, less disturbances for temperature control and therefore less movements from actuator.
- AB-QM offers full flexibility of flow adjustment – AB-QM valves can be set to a precise design value even when the system is up and running so no need for draining the system or use of flow charts or calculations – they allow full control over the real conditions in the system.
- Due to the membrane design the valves are less susceptible to blockage.
- Always the right flow, so no complaints from end-users
- Exact flow limitation at any load condition prevents excessive energy consumption that occurs when static balancing method is used in variable flow system.
- Because the AB valve covers two functions – Balancing & Control - the instalment costs are halved.
- Measuring nipples allow optimisation of the pump's energy consumption.
- 100% built in control valve authority allows lower pump head than traditional setup, thus minimizing energy consumption.
- Because of the automatic flow limiting function, commissioning costs are nonexistent. Easy adjustability allows late change of design flows without high costs.
- "Plug and Play" even when installation is not yet completely finished. For example when some floors are already occupied while construction is still going on at other floors, the occupied floors are already fully functional and balanced.

Description (continuous)

Simplifications

- Flow limitation is achieved by setting the valve to required flow - Set & Forget.
- Flow is the only parameter to be considered when designing, so easy and fast valve selection.
- Maximal flow setting of AB-QM corresponds with the maximal flow-speed through that pipe dimension according to international standards.

- Easy trouble shooting
- No control ratio calculation
- No authority calculation. Commissioning is a matter of adjusting the valve without using specialised equipment or highly educated staff.
- Compact design allows instalment where only limited space is available, for example in stand alone fan-coil units.

Applications - variable flow systems

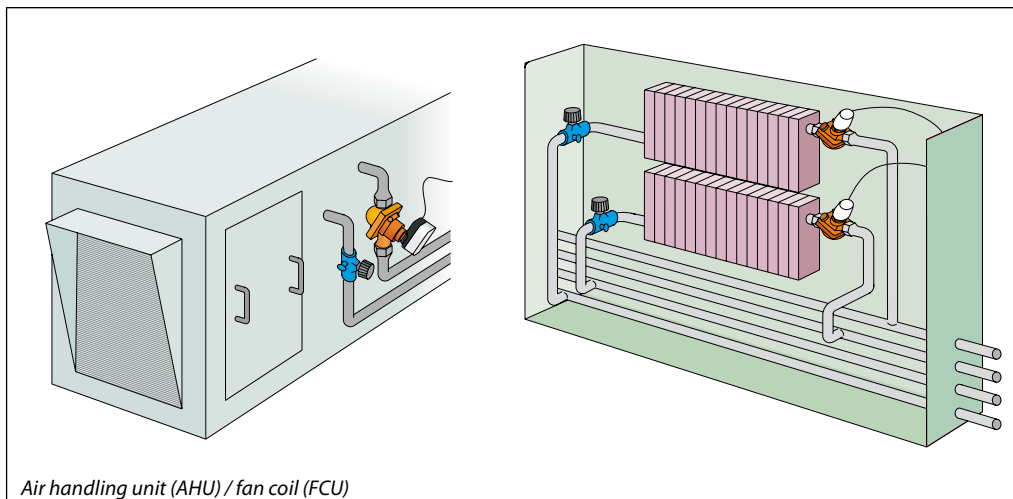

Air handling unit (AHU) / fan coil (FCU)

An AB-QM with an actuator can be used as a combined flow limiter and control valve with full authority for an AHU (Air Handling Unit). The AB-QM ensures the required flow on every AHU and simplifies the hydronic balancing of the system. Because of the integrated differential pressure controller the control valve always has 100% authority which means that partial load in the system has no influence on temperature regulation as it will have with normal control valves. By installing AB-QM the whole system

is divided in independent control loop zones not influencing each other. The flow setting is very simple. Just set the required flow for the AHU direct at the AB-QM. There is no special method needed for balancing the whole systems. This means a lot of savings in working hours. Not to forget the combination of several functions in one valve body means less valves and installation work. For temperature control AB-QM can be equipped with different actuators (on/off, 3-point, 0-10Volt) as required.

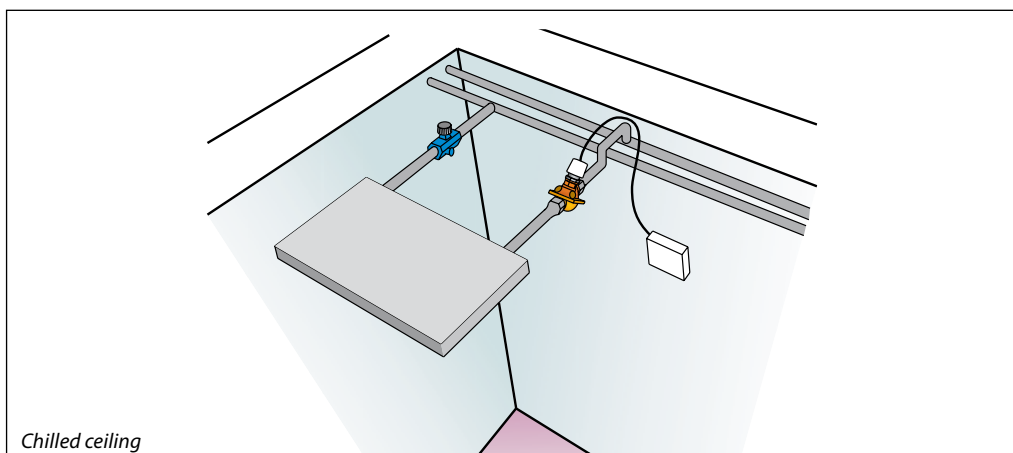

Chilled ceiling

AB-QM in systems with chilled ceilings are used to achieve the required flow in the system and to control the temperature. An AB-QM is installed at every chilled ceiling limiting the flow.

The integrated control valve is used for temperature control by mounting an actuator. Different types of actuators can be used.

Applications

- constant flow systems

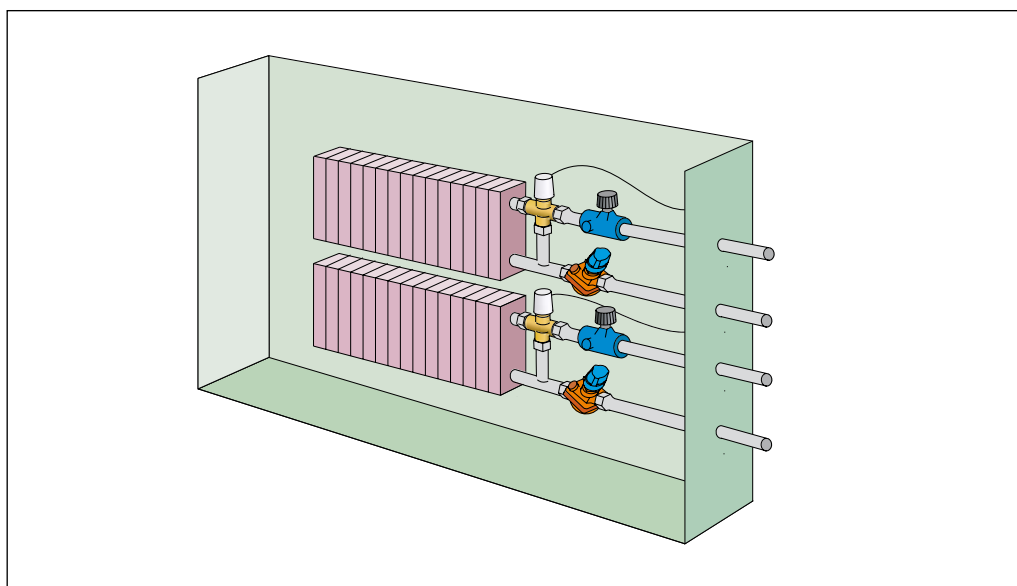

AB-QM can be used as an automatic flow controller if a system with an AHU/fan coil is run with constant flow (system with 3-way valve). There is no special balancing method needed. The flow can be set directly at the AB-QM.

Alternatively the system can be changed into a system with variable flow because AB-QM is also able to work as a control valve with full authority which means no problems with partial load.

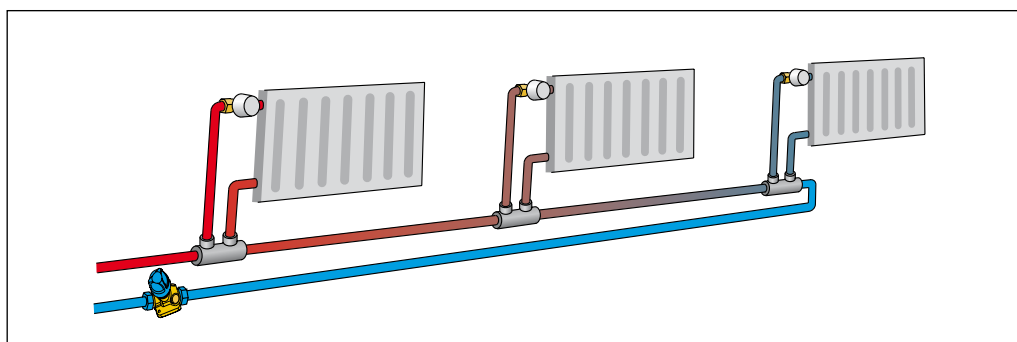

In a one pipe heating system the AB-QM can be installed as an automatic flow controller in every riser. The AB-QM limits the flow to the set value, thus automatically achieving hydronic balance in the system.

There are numerous applications in which AB-QM can be used. In principle every time you need an automatic flow controller or a control valve with full authority it can be used. For example systems with heating/cooling with concrete core activation or small substations.

Ordering
AB-QM

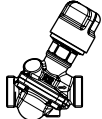
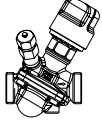
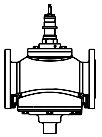
AB-QM	DN	Q _{max.} (l/h)	External thread	Code No.	AB-QM	External thread	Code No.
	10 LF	150	G ½ A	003Z0251		G ½ A	003Z0261
	10	275		003Z0201			003Z0211
	15 LF	275	G ¾ A	003Z0252		003Z0262	
	15	450		003Z0202		003Z0212	
	20	900	G 1 A	003Z0203		G 1 A	003Z0213
	25	1.700	G 1 ¼ A	003Z0204		G 1 ¼ A	003Z0214
	32	3.200	G 1 ½ A	003Z0205		G 1 ½ A	003Z0215
	40/50	10.000	G 2 ½ A	003Z0701			
	DN	Q_{max.} (l/h)	Flange connection	Code No.			
	65	18.000	PN 16	003Z0702			
	80	28.000		003Z0703			
	100	41.000		003Z0704			

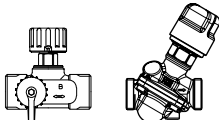

AB-QM (DN 10 - 32) can not be upgraded to AB-QM with nipples!

Set-pack (one MSV-M and one AB-QM without nipples)

Type	DN	Q _{max.} (l/h)	External thread ISO 228/1	Code No.
	10	275	G ½ A	003Z0241*
	15	450	G ¾ A	003Z0242
	20	900	G 1 A	003Z0243
	25	1.700	G 1 ¼ A	003Z0244
	32	3.200	G 1 ½ A	003Z0245

* Includes MSV-M DN15 with external thread G ¾A

Accessories & spare parts

Type	Comments		Code No.
	To pipe	To valve	
Union connection (1 pcs.) 	R ¾	DN 10	003Z0231
	R ½	DN 15	003Z0232
	R ¾	DN 20	003Z0233
	R 1	DN 25	003Z0234
	R 1 ¼	DN 32	003Z0235
	R 1 ½	DN 40/50	003Z0277
			003Z0278
Tailpiece welding (1 pcs.) 	Weld.	DN 15	003Z0226
		DN 20	003Z0227
		DN 25	003Z0228
		DN 32	003Z0229
		DN 40/50	003Z0275
			003Z0276
Tailpieces for soldering (2 nuts, 2 gaskets, 2 soldering nipples)	12x1 mm	DN 10	065Z7016
	15x1 mm	DN 15	065Z7017
Locking ring	DN 10 - 32	003Z0236	
Shut-off & protection piece (max. closing pressure 16 bar)		003Z0230	
Shut-off - plastic (max. closing pressure 1 bar)		003Z0240	

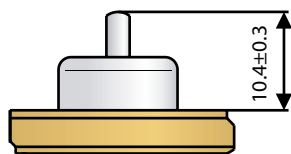
Ordering (continuous)

Closing point (measure)
for DN 10 - DN 32

Combinations AB-QM with electrical actuators

Valve type	Stroke (mm)	TWA-Z**	ABNM-Z	AMV 110NL/AME 110NL	AME 15
		Recommended ordering code numbers (for details refer to data sheets for these actuators)			
		082F1226 NC, 230 V	082F1094 Thermal actuator 24 V (0 - 10 V)	082H8056 AMV 110 NL/24 V, 24 s/mm, 3-point control	082G3028 AME15/24 V, 11 s/mm, 0 - 10 V
			082F1072 Adapter for AB-QM (M30 x 1.5)	082H8057 AME 110 NL/24 V, 24 s/mm, 0 - 10 V	
DN 10 - 20	2.25	✓	✓	✓	-
DN 25 - 32	4.50	✗*	✗*	✓	-
DN 40/50	10	-	-	-	✓
DN 65 - 100	15	-	-	-	✓

* up to 60 % of Q_{max}

** Please be aware that only this type of TWA actuator is to be used with AB-QM

Closing pressure for all actuators: 6 bar.

Technical data

Nominal diameter		DN	10 Low Flow	10	15 Low Flow	15	20	25	32	40/50	65	80	100	
Ranges	Qmin (20%)	l/h	30	55	55	90	180	340	640	2.000	-	-	-	
	Qmin (40%)		-	-	-	-	-	-	-	-	7.200	11.200	16.400	
	Qmax (100%)		150	275	275	450	900	1.700	3.200	10.000	18.000	28.000	41.000	
Diff. pressure ($p_1 - p_3$)		kPa	16 - 400				20 - 400			30 - 400				
Pressure stage		PN	16											
Control range		Acc. to standard IEC 534 control range goes to infinity as c_v characteristic is linear.												
Control valve's characteristic		Linear to be converted by actuator to equal percentage.												
Leakage acc. to standard IEC 534		max.0.01 % of k_v at 250 N						max.0.05 % of k_v at 500 N						
Flow medium		Water and water mixtures with secondary coolants (like glycols)* for closed heating and cooling systems							Water or water mixtures (secondary coolants) closed oxygen tight system					
Medium temperature		°C	-10 ... +120											
Stroke		mm	2.25				4.5			10	15			
Connection	ext. thread (ISO 228/1)	G 1/2"		G 1/2"	G 3/4"	G 3/4"	G 1"	G 1 1/4"	G 1 1/2"	G 2"	-			
	flange	-										PN 16		
	actuator	M30 x 1.5							Danfoss standard					
Materials	In the water	Valve bodies				Brass (CuZn40Pb2 - CW 617N)				GG 25				
	Out of the water	Plastic parts				POM				CuZn39Pb3 - CW 614N; W.Nr. 1.4310; W.Nr. 1.4401				
		Membranes and O - rings				EPDM				EPDM				
		Springs				W.Nr. 1.4568; W.Nr. 1.4310				W.Nr. 1.4568; W.Nr. 1.4310				
		Cone (Pc)				W.Nr. 1.4305				CuZn40Pb3 - CW 614N, W.Nr. 1.4305				
		Seat (Pc)				EPDM				W.Nr. 1.4305				
		Cone (Cv)				CuZn40Pb3 - CW 614N				CuZn40Pb3 - CW 614N				
		Seat (Cv)				CuZn40Pb2 - CW 617N				W.Nr. 1.4305				
		Screw				Stainless Steel (A2)				Stainless Steel (A2)				
		Flat gasket				NBR				NBR				
		Sealing agent (only for valves with measuring nipples)				Dimethacrylate Ester								

* according suitability and usage especially in not oxygen tight systems please mind the instructions given by the coolant producer

Pc - pressure controller part

Cv - Control valve part

Design

- 1 Stuffing box
- 2 Spindle
- 3 Plastic ring
- 4 Control valve's cone
- 5 Membrane
- 6 Main spring
- 7 Hollow cone (pressure controller)
- 8 Vulcanized seat (pressure controller)

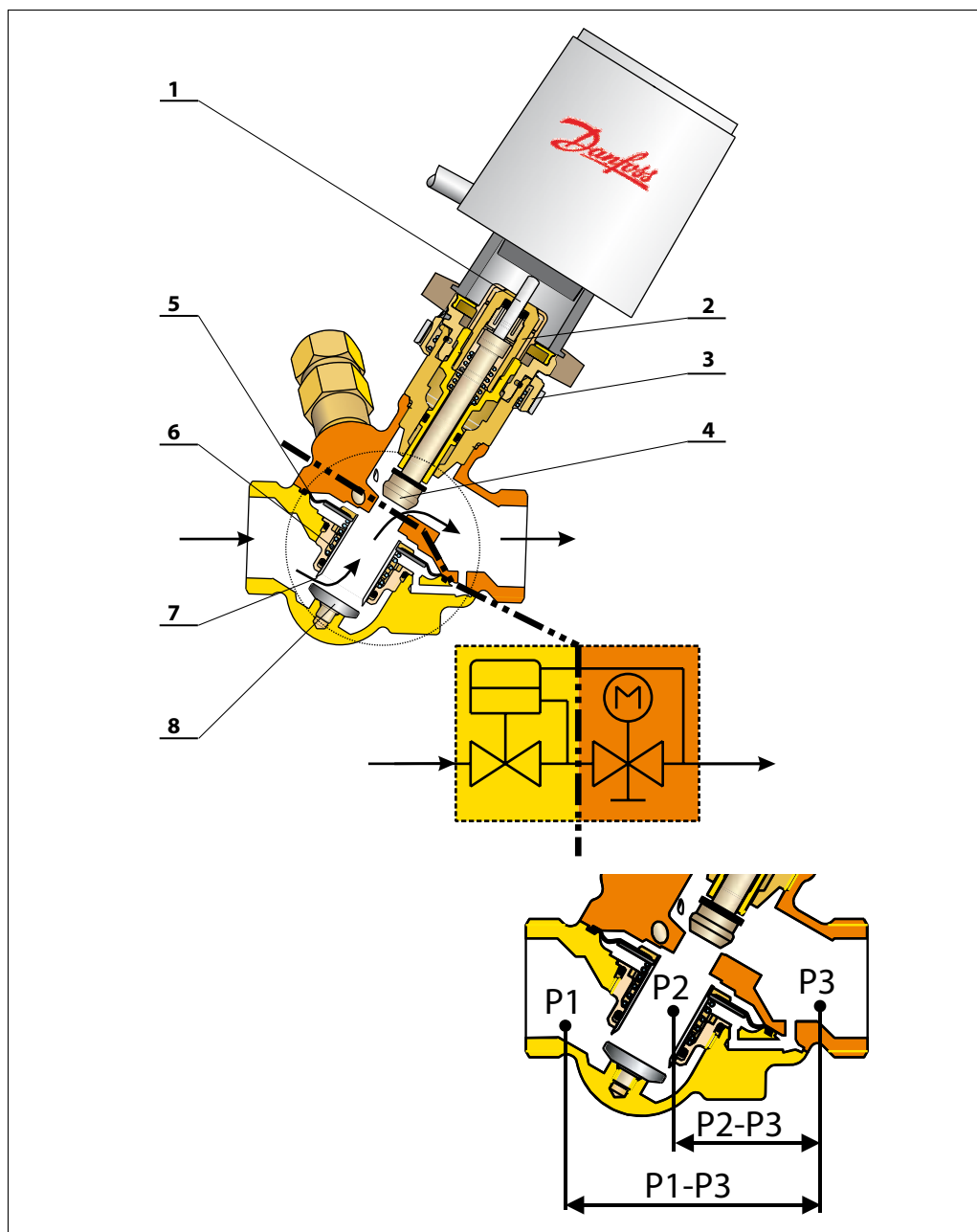

Function:

The AB-QM valve consists of two parts:

- 1. Differential pressure controller
- 2. Control valve

1. Differential pressure controller BV

The differential pressure controller maintains a constant differential pressure across the control valve. The pressure difference (p_2-p_3) on the membrane is balanced with the force of the spring. Whenever the differential pressure across the control valve changes (due to a change in available pressure, or movement of the control valve) the hollow cone is displaced to a new position which brings a new equilibrium and therefore keeps the differential pressure at a constant level.

2. Control valve CV

The control valve has a linear characteristic. It features a stroke limitation function that allows adjustment of the K_v value. The percentage marked on the scale equals the percentage of 100% flow marked on the pointer. Changing the stroke limitation is done by lifting the blocking mechanism and turning the top of the valve to the desired position, showed on the scale as a percentage. A blocking mechanism automatically prevents unwanted changing of the setting.

Sizing

Example 1: Variable flow system

Given:

Cool requirement per unit : 1000 W
 Flow temperature in the system: 6 °C
 Return temperature in the system: 12 °C

Required - control and balancing valves:

AB-QM and actuators type for BMS system.

Solution:

Flow in the system: Q (l/h)
 $Q = 0.86 \times 1000 / (12-6) = 143 \text{ l/h}$

Selected:

AB-QM DN 10 mm with $Q_{max} = 275 \text{ l/h}$
 presetting on $143/275 = 0.52 = 52 \%$ of maximum opening.

Actuators: AMV 110NL - 24 V

Remarks:

required minimum differential pressure across the AB-QM DN 10 - 16 kPa.

Example 2: Constant flow system

Given:

Cool requirement per unit : 4000 W
 Flow temperature in the system : 6 °C
 Return temperature in the system : 12 °C

Required - automatic flow limiter:

AB-QM and presetting.

Solution:

Flow in the system : Q (l/h)
 $Q = 0.86 \times 4000 / (12-6) = 573 \text{ l/h}$

Selected:

AB-QM DN 20 mm with $Q_{max} = 900 \text{ l/h}$
 presetting on $573/900 = 0.64 = 64 \%$ of maximum opening.

Remarks:

required minimum differential pressure across the AB-QM DN 20 - 16 kPa.

Example 3: Sizing AB-QM according pipe dimension

Given:

Flow in system 1.4 m³/h (1400 l/h = 0.38l/s), pipe dimension DN 25 mm

Required - automatic flow limiter:

AB-QM and presetting.

Solution:

In this case we can selected AB-QM DN 25 mm with $Q_{max} = 1700 \text{ l/h}$

In this case it will be recommended to check the maximum velocity in the pipe. For this we calculate velocity in the pipe for condition: DN 25 mm – Di 27.2 mm

Dimension and condition acceptable, velocity below 1.0 m/s.

Presetting on the valve AB-QM DN 25 mm $1400/1700 = 0.82 = 82 \%$ of maximum opening.

Remarks:

required minimum differential pressure across the AB-QM DN 25 - 20 kPa.

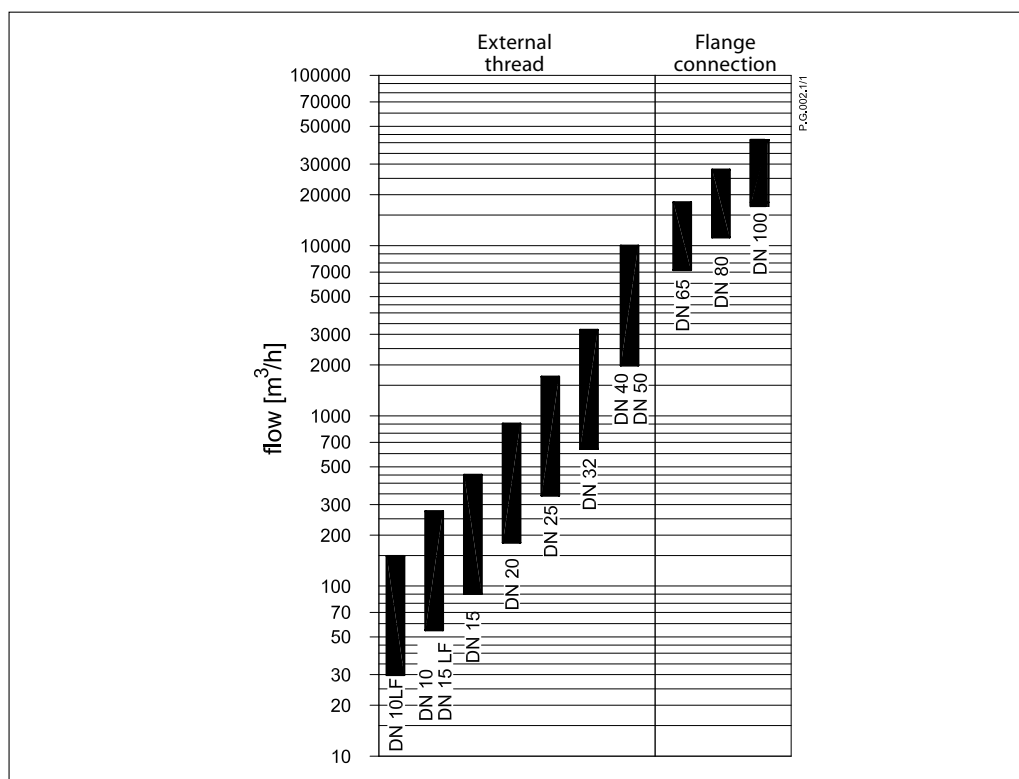

Pump optimising /
Trouble shooting

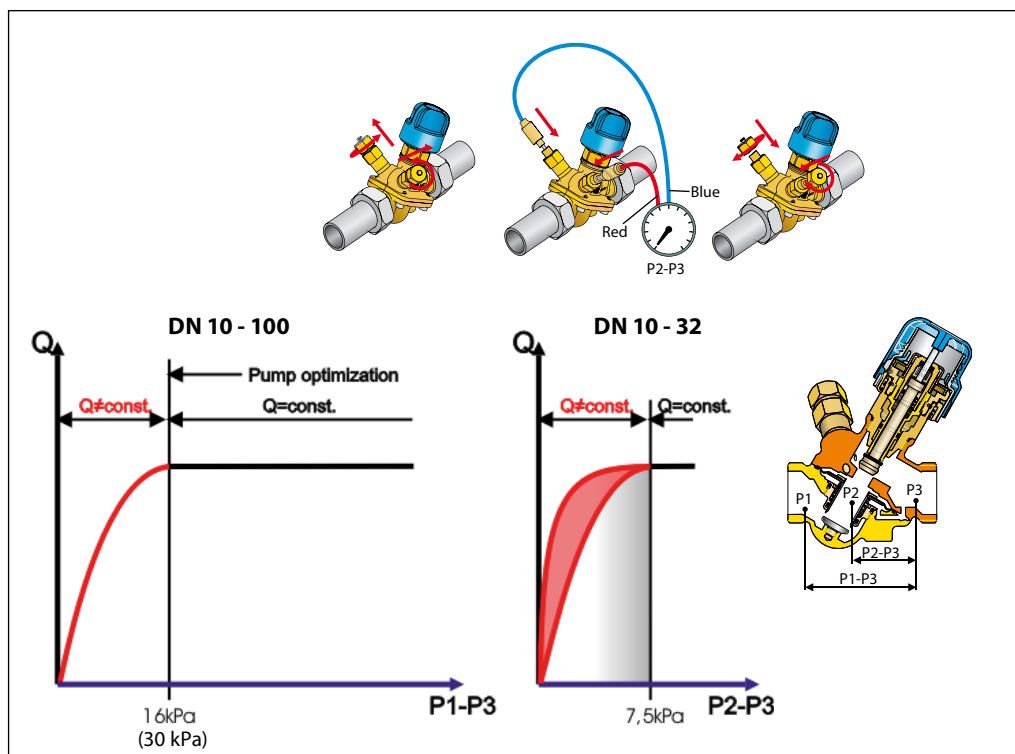

The AB-QM (DN 10-32) features measuring nipples that allow measuring of the pressure difference (p2-p3) across the control valve while AB-QM (DN 40-100) measuring is done between p1 to p3. If the pressure difference exceeds certain value it means the differential pressure controller is operational and the flow limitation is achieved. The measuring function can be used to verify if enough pressure difference is available and thus verify the flow.

It can also be used to optimize the pump head. The pump head can be decreased until no more than the minimal required pressure is available on the most distant valve (in terms of hydronic). This optimal point is to be found when proportionality between pump head and measured differential pressure cease to exist. Verifying the pressure can be done by using a Danfoss PFM 3000 for example (for more details please refer to AB-QM Tech Note).

Presetting
(DN 10 - 32)

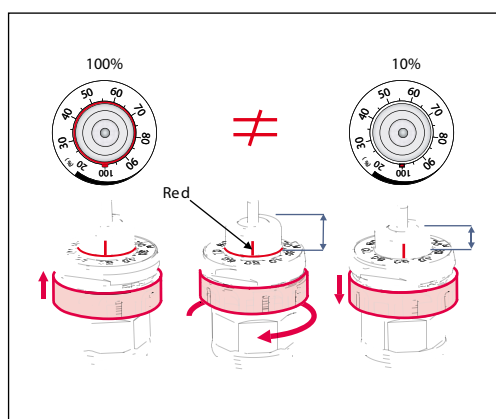

The calculated flow can be adjusted easily without using special tools.

To change the presetting:

- Remove the blue protective cap or the mounted actuator.
- Raise the grey plastic ring and turn to the new presetting.
- Release the white plastic ring and the presetting is locked.

The presetting scale indicates a values from 100% flow to 0% closed. Counter clock wise turning would increase the flow value while clock wise would decrease it.

When valve is set to 80% or more the red ring (below "DN max flow " sign) becomes visible.

If the valve is a DN 15 then the max flow = 450 l/h = 100% presetting. To set a flow of 270 l/h you have to set: $270/450 = 60\%$.

Danfoss recommends a presetting/flow from 20% to 100%. Factory presetting is 100%.

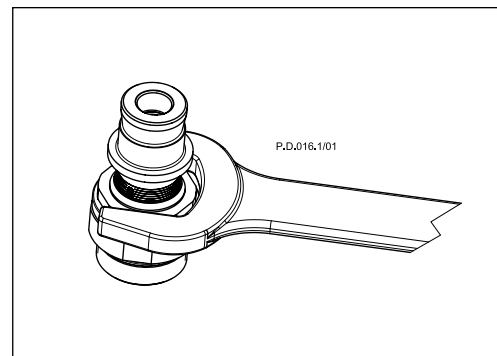
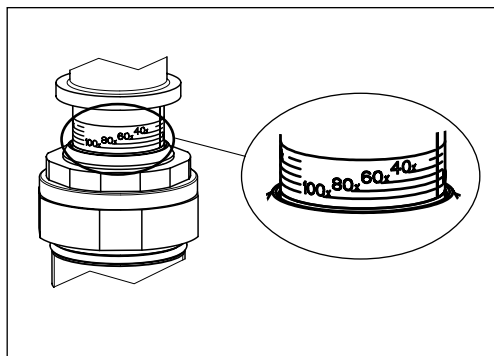
Presetting (continuous)
DN 40/50 - 100

Service
DN 10 - 32

The valve features a service function that allows changing of the “stuffing box (code 065F0006)” under water pressure.

Valves are equipped with plastic shut-off mechanism that is to be used for isolating function up to 1 bar differential pressure. When closing against higher differential pressure please use accessory - shut-off & protection piece (003Z0230) or set the value to 0%.

Unwanted change of the setting is provided by locking ring (code 003Z0236) which is inserted in the groove below the scale. The locking ring would not allow one to lift the grey plastic ring thus no change of the setting is possible.

DN 40/50 - 100

Valves are equipped with manual shut-off for isolating function up to 16 bar .

Installing

AB-QM valve is mono-directional meaning that the valve operates when arrow on the valve body is aligned with flow direction. When this rule is disobeyed the valve acts like variable orifice that cause water hammer at sudden closing when available pressure has increased or valve have been set to lower value.

In case when system condition allows backflows it is strongly recommended to use backflow preventer in order to avoid possible water hammer that can damage the valve as well as other elements in the system.

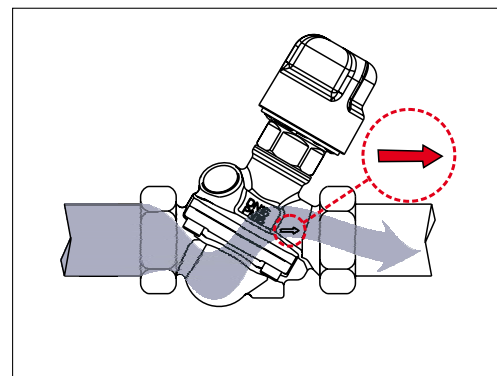

Tender text

The pressure independent balancing and control valve should be comprised of a linear control valve and an integrated membrane based pressure controller. The valve could be used as an automatic flow limiter.

The valve should have a mechanism to adjust the flow stepless from 100% to 0% (closed) of the maximum flow. The adjustment should be performed without a tool for dimensions up to DN 32 or a standard tool for valves bigger then DN 32. The setting, which can be locked, should be visible from the top for valves DN 32 and smaller and from the side for valves bigger then DN 32.

The control valve stuffing box should be serviceable under pressure for valves up to DN 32 .
The valves should have a shut-off function (positive), separate from the setting mechanism, for valves bigger then DN 32.

The leakage rate should be: max. 0.01% of the k_v at 250 N for valves up to DN 32, and for valves up to DN 100 0.05% at 500 N (IEC 543).

The authority of the pressure independent control valve should be 1. Because the control valve should have a linear characteristic, acc. to standard IEC 534 the control ratio will go to infinity.

The maximum flow for every valve dimension should correspond with the VDI 2073 recommendation (the optimum between pump consumption, noise emission and investment in pipes).

Minimum (starting pressure for flow limitation) differential pressure should be 16 kPa for valves up to DN 20, 20 kPa valves up to DN 32 and 30 kPa for valves up to DN 100.

Nominal pressure rating 16 bar, maximal test pressure 25 bar.

Measuring points for pump optimization and flow verification should be available as an option for DN 10-32 and standard for DN 40/50 - 100.

Nominal diameter: _____
 Connection: _____
 Adjustment range from - to _____ m³/h
 Produced by: Danfoss
 Type: AB-QM
 Ordering no.: 003Z02_

Dimensions

AB-QM DN 10 - 32

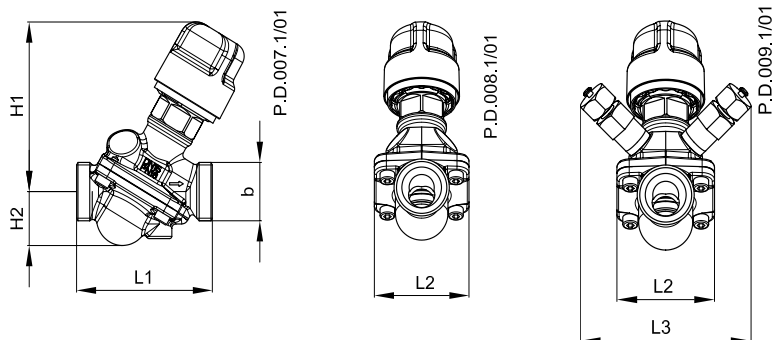

AMV 110 NL / AME 110 NL + AB-QM

TWA-Z + AB-QM

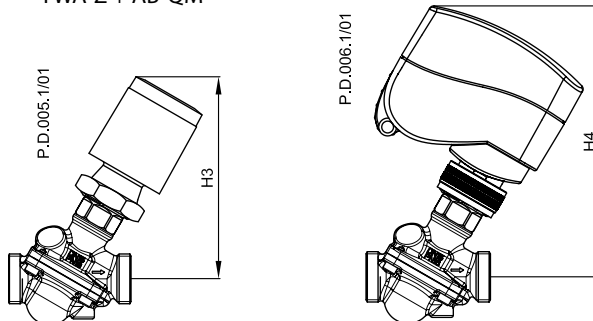

AME 15 + AB-QM

AB-QM DN 40/50

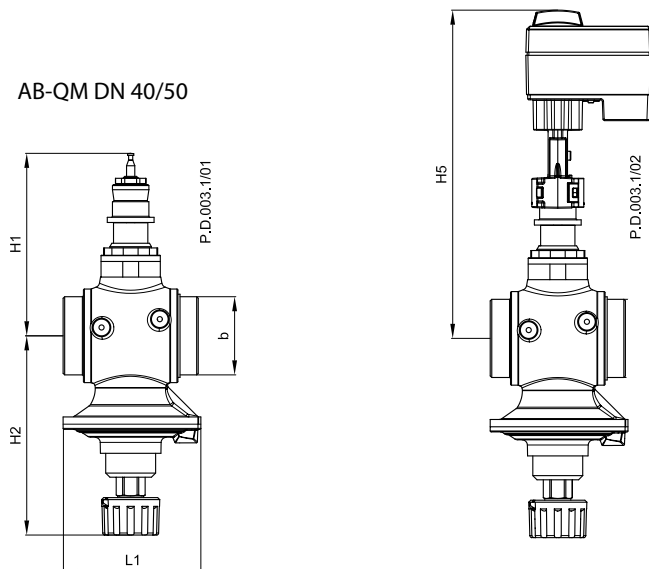

Type	L ₁ mm	L ₂ mm	L ₃ mm	H ₁ mm	H ₂ mm	H ₃ mm	H ₄ mm	H ₅ mm	b ISO 228/1	Weight kg
AB-QM DN 10	53	36	79	20	73	105	140	-	G ½ A	0.38
AB-QM DN 15	65	45	79	25	75	110	145	-	G ¾ A	0.48
AB-QM DN 20	82	56	79	33	77	115	150	-	G 1 A	0.65
AB-QM DN 25	104	71	79	42	88	130	165	-	G 1¼ A	1.45
AB-QM DN 32	130	90	79	50	102	145	180	-	G 1½ A	2.21
AB-QM DN 40/50	133	-	-	174	192	-	-	315	G 2½ A	6,87

Dimensions (continuous)

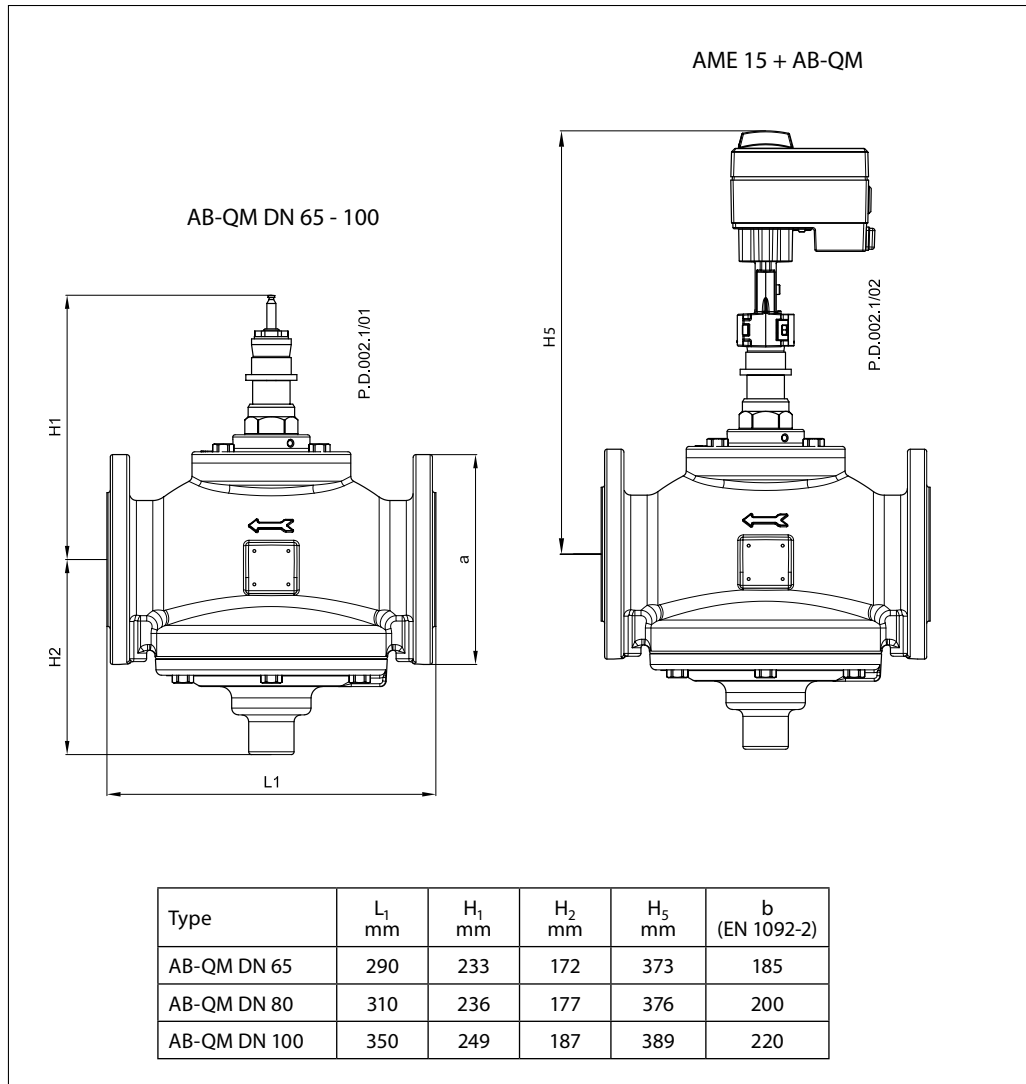

Danfoss can accept no responsibility for possible errors in catalogues, brochures and other printed material. Danfoss reserves the right to alter its products without notice. This also applies to products already on order provided that such alterations can be made without consequential changes being necessary in specifications already agreed. All trademarks in this material are property of the respective companies. Danfoss and the Danfoss logotype are trademarks of Danfoss A/S. All rights reserved.

