

DZR Gate Valve

Crane gate valves offer the ultimate in dependable service wherever minimum pressure drop is important.

Materials

Part	Material	Sizes
Body	DZR Brass BSEN12165 CW602N	All
Bonnet	DZR Brass BSEN12165 CW602N	All
Stem	DZR Brass BSEN12164 CW602N	All
Packing Nut	Brass BSEN12164 CW712R	All
Packing	PTFE	All
Stem Bush	DZR Brass BSEN12164 CW602N	All
Disc	DZR Brass BSEN12165 CW602N	All
Handwheel	Aluminium	All
Handwheel Nut	Steel (Zinc Plated)	All



Dimensional Drawing

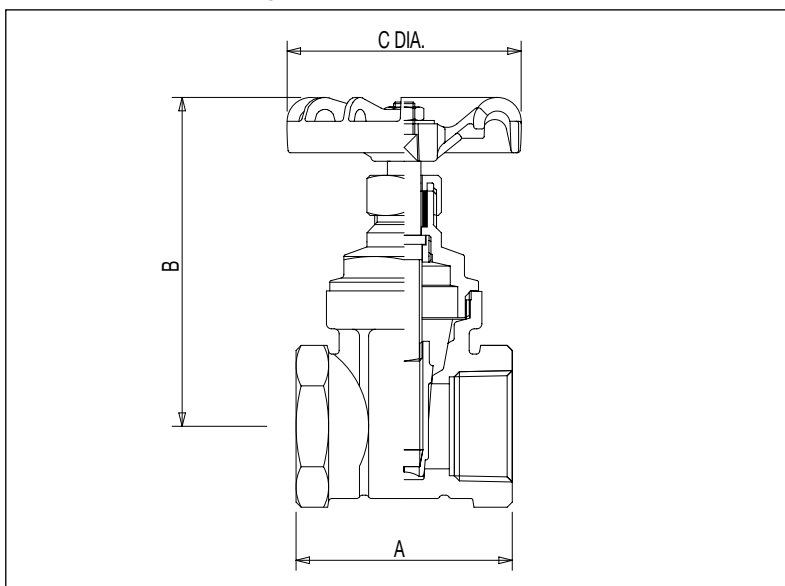

Dimensions and Weights

Size	Weight (kg)	A (mm)	B (mm)	C (mm)
1/4"	0.2	43	69	45
3/8"	0.19	43	69	45
1/2"	0.23	50	69	45
3/4"	0.36	54	79	52
1"	0.5	62	92	52
1.1/4"	0.82	70	108	65
1.1/2"	1.08	72	125	70
2"	1.83	82	150	92
2.1/2"	2.9	97	176	103
3"	3.97	111	204	120

Pressure Rating: PN20

End Connection: BSEN10226 formerly BS21 Taper

Operator: Handwheel

Gate valves are best for services that require infrequent valve operation, and where the disk is kept either fully opened or fully closed. They are not practical for throttling.

Specification:

Valves are manufactured in accordance with BSEN12288 (formerly BS5154) PN20 for Series B ratings. Non Rising Stem

This valve is not suitable for use on group 1 gasses or unstable fluids, as defined by the Pressure Equipment Directive 97/23/EC. Temperature operating range: -10 to 180°C.

Available Options:

P150 locking device.