

TECHNICAL DATASHEET

PRISM

SMALL BASIN MIXER WITH POP-UP WASTE

Product Specification

Product Code:	PM SMBAS B/W*
Finishes (*):	*Black/White
Product Type:	Contemporary
Construction:	Body is all brass construction and is designed to conform to BS EN 200
Cartridge/Valve Type:	35mm Ceramic Cartridge
Supply:	Suitable for high pressure plumbing systems only
Inlet Connections:	15mm Copper Tails (supplied)
Outlet Connection:	Flow straightener M24, Male
Service Connection Type:	N/A
Electrical Supply:	N/A
Max Ratio:	N/A
Water Pressure:	Min 0.2 bar, Max 10.0 bar
Dimensions for Fitting:	34 - 38mm

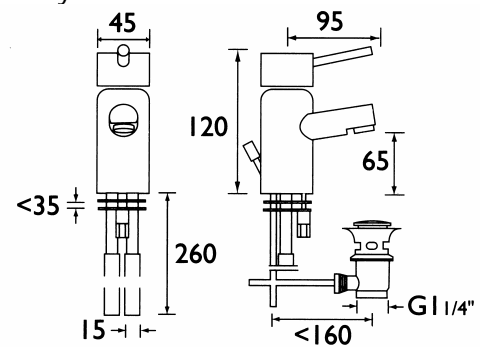

Additional Information

- Chrome plated to BS EN 248 (peg, flow straightener housing, shroud, plug, waste, rod), Black/White powder coated (body, spout, handle body)
- 'Bristan' logo laser etched on handle top (back centre)
- 'H', 'C' and arrows laser etched on front of handle, on either side of the peg

Technical Advice: For further information please call 0844 7016273 or email customer care@bristan.com.
Guarantee: 5 years covering manufacturing faults.

Compliance/Approvals

WRAS:	under validation
BEAB:	N/A
Additional Awards:	N/A

Flow Rates

System Pressure	0.2bar	0.5bar	1bar	2bar	3bar	4bar
PM SMBAS B/W	5.5	9.2	13.0	18.7	23.0	26.7