

TWIST

Twist 1700 x 700mm Single Ended Bath

Product Specification

Product Code:	TW AB 170X70 SE BTH W
Finishes:	White
Product Type:	Contemporary
Construction:	5mm Cast Acrylic and designed to conform to BS4305-1 and BS4305-2
Capacity to Overflow:	185 Litres

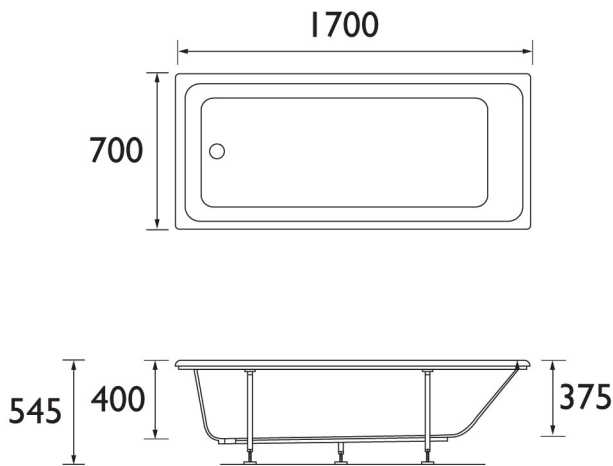

Additional Information

- Manufactured from 5mm sanitary grade, cast acrylic sheet.
- Reinforced with a thick layer of fibreglass resin and 15mm encapsulated base – board
- Machine finished edges.
- Tubular steel combined rim and base support with robust M10 adjustable feet and central support foot.
- Un-drilled for compatibility with a variety of bath fittings.
Compatible with: - Quest Front Panel (QST AB 170 PANEL W) and Quest End Panel (QST AB 70 PANEL W).

Technical Advice: For further information please call 0844 7016273 or email customer@bristan.com
Guarantee: 5 years covering manufacturing faults