

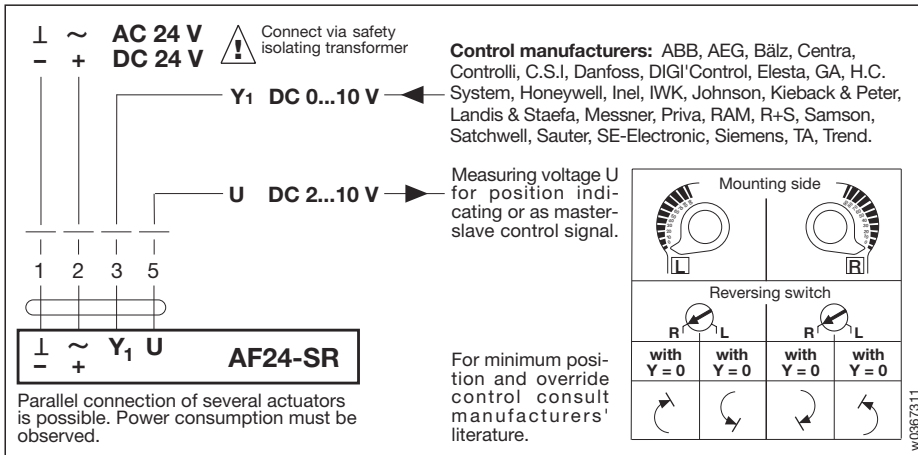

p00119805

Wiring diagram



w0367311

Technical data	AF24-SR
Nominal voltage	AC 24 V 50/60 Hz, DC 24 V
Nominal voltage range	AC 19.2...28.8 V, DC 21.6...28.8 V
For wire sizing	10 VA
Power consumption	6 W motoring, 2.5 W holding
Connecting cable	1 m long, 4x0.75 mm ²
Control signal Y ₁	DC 0...10 V @ input resistance 100 kΩ (0.1 mA)
Operating range	DC 2...10 V
Measuring voltage U	DC 2...10 V @ max. 0.5 mA (for 0...100% angle of rotation)
Synchronisation tolerance	± 5%
Direction of rotation	- motor selected with switch L/R - spring selected by L/R mounting
Torque	- motor min. 15 Nm (at rated voltage) - spring return min. 15 Nm
Angle of rotation	max. 95° (adjustable from 33% in 5.5% steps ↯ with a supplied limit stop)
Running time	motor 150 s, spring return ≈ 16 s
Sound power level	motor max. 45 dB(A), spring ≈ 62 dB(A)
Service life	≈ 60 000 operations
Position indication	mechanical
Protection class	⚡ (safety extra-low voltage)
Degree of protection	IP 54
Ambient temperature range	-30... +50 °C
Non-operating temperature	-40... +80 °C
Humidity test	to EN 60730-1
EMC	CE according to 89/336/EEC
Maintenance	maintenance-free
Weight	2700 g

Dampers up to approx. 3 m²

Modulating actuator (AC/DC 24 V)

Control DC 0...10 V

(The type AF24-SR20 is available with phasecut input)

Position feedback DC 2...10 V

Manual operation with integral position stop

Versatile applications

For the operation of air dampers that perform safety functions (e.g. frost and smoke protection, hygiene, etc.).

Improved functional safety

The AF24-SR actuator moves the damper to its normal working position while tensioning the return spring at the same time. If the power supply is interrupted, the energy stored in the spring moves the damper back to its safe position.

The actuator is overload proof, needs no limit switches and halts automatically at the end stop.

Simple installation and commissioning

The actuator is fitted with a universal spindle clamp for quick and easy mounting directly onto the damper spindle. The actuator is also supplied with an anti-rotation strap for fixing it in position. The damper can be operated manually and locked in any required position. Release of the locking mechanism can be achieved manually or automatically by applying the supply voltage.

If manual operation is used while the power supply is still switched on, the actuator will check itself by running first to the start position and then to the position dictated by the control signal Y.

Electrical accessories (see Doc. 2. Z-...)

- SG...24 Positioners
- ZAD24 Digital position indicator

Mechanical accessories

- ZG-AF Damper linkage kit, page 9

Control and monitoring functions, page 7

Mounting instructions, page 10

Important

Read the notes about the use and torque requirements of the damper actuators on page 3.

Dimensions

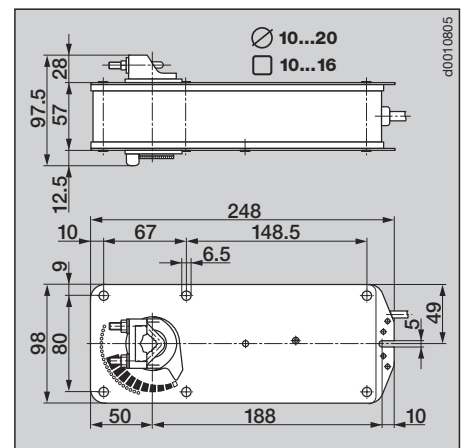

d00119805