

DONKIN SERVICE ISOLATION VALVE

451/50
451/70
451/73

The Series 51, gas service isolation valve, is a high quality ball valve for the isolation of gas services to domestic and commercial premises. It is designed to meet the requirements of GIS/V4 and GIS/PL3 Part 1.

Features:

- Available with factory fitted PE tailpieces PE80/PE100 (or combination of PE/screwed connections) in 25, 32 and 63mm sizes.
- Screwed BS21 taper internal thread branch connections in 3/4" to 2" sizes.
- Maintenance free compact design.
- Pre-loaded PTFE Seats.
- High integrity, one piece SG iron body.
- Corrosion resistant construction.
- High torque design to prevent unauthorised operation.
- 19mm square false cap as standard.
- Kitemark approved to GIS/V4 and

Options:

- Seal in false cap skirt to prevent ingress of dirt.
- Where covered by the requirements of the Pressure Equipment Directive these products are produced in full compliance and carry CE marking.
- Extra long PE tailpieces.
- Option of 25mm false cap.
- Option of Double Block and Bleed on 2".
- Option of lever operation.
- GIS/PL3 Part 1.
- PE100 Tailpieces

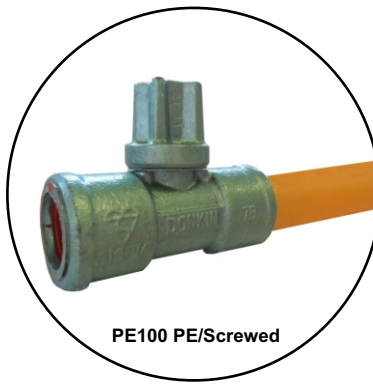

The designs, materials and specifications shown are subject to change without notice due to our continuing programme of product development.

AVK UK Limited

DS100811

DONKIN SERVICE ISOLATION VALVE

451/50
451/70
451/73

APPLICABLE STANDARDS

GIS/V4, GIS/PL3.

MATERIALS OF CONSTRUCTION

No.	DESCRIPTION	MATERIAL
1	Body	SG iron EN 1563 - GJS - 400 - 15.
2	Ball	Stainless steel. BS EN 1072 316S31.
3	Seat	15% graphite filled PTFE.
4	'O' Rings	Nitrile Rubber. EN 682.
5	Washer, Disc Spring Stem and Gland	Stainless steel. BS 1449.

SERVICE CONDITIONS

Maximum working pressure	7 Bar (100 psig).
Screwed both ends:	
Maximum working pressure	4 Bar(60 psig) PE80
PE tail(s):	7 Bar(100psig) PE100
Temperature range:-	10°C to + 50°C (+40°C if PE ends.)

DIMENSIONS & WEIGHTS

SERIES 51 (SCREWED ENDS)

VALVE SIZE	¾"	1"	1½"	2"
A	11.5mm	14.5mm	20mm	30mm
B	84mm	99mm	125mm	146mm
C	56mm	58mm	76mm	69mm
D	36mm	44mm	60mm	77mm
WEIGHT	0.37Kg	0.9Kg	1.50Kg	2.2Kg

DIMENSIONS & WEIGHTS

SERIES 51 (POLYTHENE ENDS FITTED)

VALVE SIZE	25mm	32mm	63mm
A	11.5mm	14.5mm	30mm
B	310mm	302mm	436mm
C	72mm	73mm	84mm
WEIGHT	1.0Kg	1.3Kg	3.65Kg

DIMENSIONS & WEIGHTS

SERIES 51 PE (SCREWED/PE END)

VALVE SIZE	¾" x 25mm	1" x 32mm	2" x 63mm
A	11.5mm	14.5mm	30mm
B	197mm	201mm	291mm
C	72mm	73mm	84mm
D	35mm	43mm	71mm
WEIGHT	0.87Kg	1.1Kg	3.1Kg

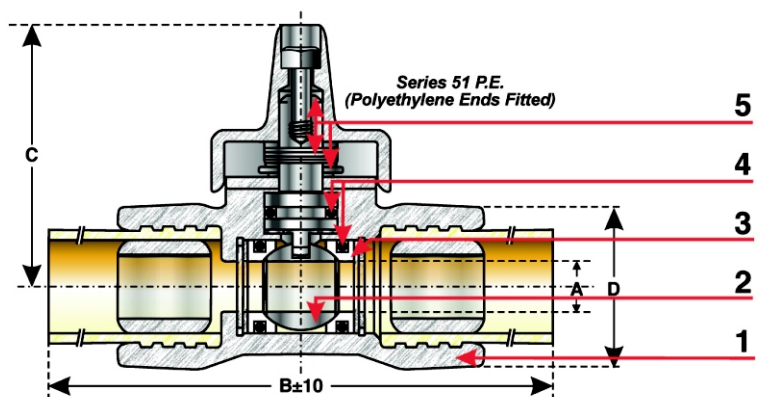
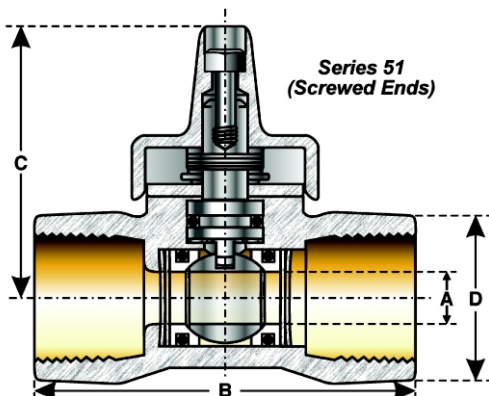
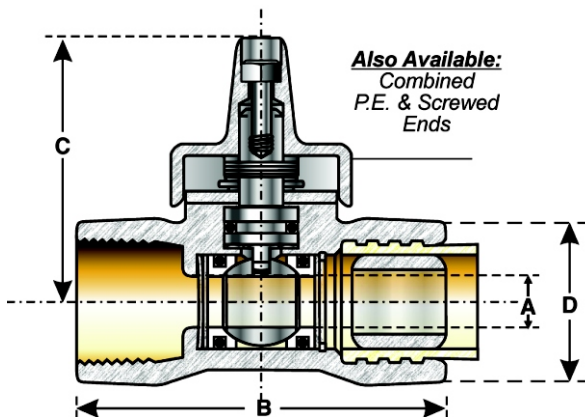

AVK UK Limited

Northampton Office
8 Rushmills, Northampton,
NN 4 7YB England, UK.
Tel.: +44 (0) 1604 601188
Fax.: +44 (0) 1604 604818

Chesterfield Office
Colliery Close, Ireland Ind. Est., Staveley,
Chesterfield, S43 3FH England, UK.
Tel.: +44 (0) 1246 479100
Fax.: +44 (0) 1246 479200

www.avkuk.co.uk