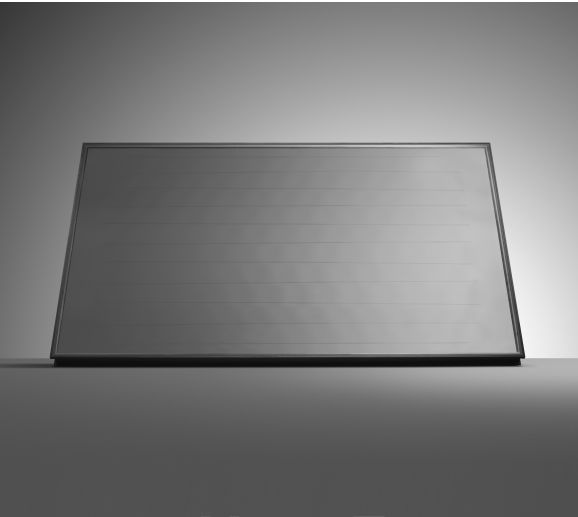


# auroTHERM



VFK 125  
VFK 135 D  
VFK 140 D  
VFK 145 H/V  
VFK 150 H/V



**GB**



For the expert technician

# Installation manual auroTHERM

On-roof/flat roof installation

VFK 145 H/V  
VFK 150 H/V

## Contents

<b>1</b>	<b>Notes on the documentation.....</b>	<b>2</b>
1.1	Other applicable documents .....	2
1.2	Document storage .....	2
1.3	Symbols used .....	2
1.4	Applicability of the manual.....	2
<b>2</b>	<b>Intended use .....</b>	<b>2</b>
2.1	Combination with other components .....	2
2.2	Operational conditions .....	3
2.3	CE mark .....	3
<b>3</b>	<b>Safety information .....</b>	<b>3</b>
3.1	Technical Guidance.....	3
3.2	Related documents.....	3
3.3	Regulations for the prevention of accidents ...	4
3.4	Lightning protection.....	4
3.5	Frost protection.....	4
<b>4</b>	<b>Before installation .....</b>	<b>5</b>
4.1	Safety information.....	5
4.2	Scope of delivery .....	6
4.2.1	On-roof mounting .....	6
4.2.2	Flat roof installation.....	7
4.3	Collector field packaging.....	8
4.4	Interconnection diagram.....	9
4.5	Hydraulic connection preparation.....	10
4.5.1	On-roof mounting .....	10

4.5.2	Flat roof installation.....	10
4.6	Required tools.....	10
<b>5</b>	<b>Flat roof installation .....</b>	<b>10</b>
5.1	Collector position and field arrangement.....	10
5.2	Weighting and arrangement of the frames.....	11
5.3	Collector installation .....	12
<b>6</b>	<b>On-roof mounting.....</b>	<b>16</b>
6.1	Collector position and field arrangement.....	16
6.2	Roof anchor installation.....	17
6.2.1	Roof anchor type P (pantile).....	19
6.2.2	Roof anchor type S and roof anchor type S flat (for beaver tail).....	21
6.2.3	Stair bolt mounting kit.....	22
6.3	Collector installation .....	22
<b>7</b>	<b>Concluding work .....</b>	<b>27</b>
<b>8</b>	<b>Recycling and disposal.....</b>	<b>27</b>
8.1	Collectors .....	27
8.2	Packaging.....	27
8.3	Solar fluid.....	27
<b>9</b>	<b>Vaillant Customer Service and warranty ..</b>	<b>27</b>
9.1	Vaillant warranty.....	27
9.2	Vaillant Service.....	27
<b>10</b>	<b>Technical data.....</b>	<b>28</b>

GB

# 1 Notes on the documentation

## 2 Intended use

### 1 Notes on the documentation

The instructions below are intended to help you throughout the entire documentation.

#### 1.1 Other applicable documents

All installation instructions of flat collectors and components of the installation must be observed when installing the solar system. These instructions are included with the individual components of the system and the additional components.

**We accept no liability for any damage caused by failure to observe these instructions.**

#### 1.2 Document storage

Please pass on this installation manual and all other applicable documents and auxiliary equipment to the plant operator, whose responsibility it is to ensure the manuals and auxiliary equipment are available whenever required.

#### 1.3 Symbols used

Please observe the safety instructions in this installation manual for the installation of the collector!



**Danger!**  
**Immediate risk of serious injury or death!**



**Danger!**  
**Risk of death from electric shock!**



**Danger!**  
**Danger of burning and scalding!**



**Caution!**  
**Potentially dangerous situations for the product and the environment!**



**Note**  
**Useful information and instructions.**

- Symbol indicating the required action

#### 1.4 Applicability of the manual

These installation manual applies exclusively to flat collectors with the following article numbers:

Collector type	Article number
VFK 145 H	0010004457
VFK 145 V	0010004455
VFK 150 H	0010006285
VFK 150 V	0010006283

**Table 1.1 Collector types and article numbers**

For the flat collector article number please see the identification plate on the upper collector edge.

Vaillant flat collectors are available in different versions: one for the horizontal position, one for the vertical position.

Besides, collectors in the collector field can be arranged side by side and on top of each other.

**Generally, the installation steps and the instructions described in this manual are valid for both collector positions and field arrangements.**

Any different installation steps are clearly pointed out:



**With horizontal collector position**



**With vertical collector position**



**With fields arranged side by side**



**With fields arranged on top of each other**

## 2 Intended use

The Vaillant auroTHERM flat collectors are built and designed according to accepted safety rules and regulations.

Nevertheless, improper use may cause danger to life and limb of the user or third parties and could impair the operation of the unit and other objects.

The unit is not intended for use by persons (including children) with reduced physical, sensory or mental capabilities, or lack of experience and/or knowledge, unless they have been given supervision or instruction concerning use of the unit by a person responsible for their safety.

Children must be watched to ensure that they do not play with the unit.

Vaillant auroTHERM flat collectors are used for heating support and for solar hot water generation.

Any other use or use exceeding the above-mentioned applications shall be considered as improper use. The manufacturer/supplier shall not be responsible for any damages resulting from such improper use. The user alone bears the risk.

Intended use includes observance of the operating and installation manuals and all other applicable documents, as well as adherence to the maintenance and inspection conditions.



**Caution!**  
**Any improper use is forbidden!**

### 2.1 Combination with other components

Vaillant flat collectors should be combined only with Vaillant components (fixing, connections) and system components.

The use of other components or system components shall be considered as improper use. We accept no liability.



## 2.2 Operational conditions



**Caution!**  
**The roof may collapse!**  
Mount the flat collectors only on roofs with a sufficient load-carrying capacity.  
If necessary, call a technician.

**Caution!**  
**Collector damage!**  
Flat collectors are suitable for a maximum snow load of 5.0 kN/m<sup>2</sup> and a maximum wind load of 1.6 kN/m<sup>2</sup>.

### On-roof mounting:

The flat collectors can be mounted on roofs with inclinations from 15° to 75°.

### Flat roof installation:

Flat collectors can be installed on flat roof frames in the as-delivered condition with an angle of 30°, 45° or 60°.

## 2.3 CE mark

The CE mark certifies that the appliances, according to the models available, satisfy the basic requirements of the following directives:

- Directive 97/23/EWG of the European Parliament and Council for approximation of the laws of the member states regarding pressure equipment



auroTHERM flat collectors are built according to the state of the art and recognised safety rules and regulations. Conformity with the applicable standards has been demonstrated.



auroTHERM flat collectors have been successfully tested according to the rules and requirements for the Solar Keymark.

## 3 Safety information

The following safety instructions, technical rules and accident prevention regulations must be observed when installing the flat collectors.



**Danger!**  
**Danger to life as a result of falling from the roof!**  
**Danger to life from parts falling from the roof!**  
**Observe the applicable national regulations for working at heights.**



**Danger!**  
**Danger of burning and scalding!**  
In case of solar irradiation inside the units, collectors can reach 200 °C. Remove the sun protection film installed at the factory only after the solar energy system has been started up.



**Danger!**  
**Danger of burning and scalding!**  
In case of solar irradiation inside the units, collectors can reach 200 °C.  
Do not perform maintenance work under direct sunlight.



**Caution!**  
**Risk of corrosion!**  
On roofs made of metals more noble than aluminium (e.g. copper roofs) galvanic corrosion can occur at the anchor points, whereby the attachment of the collectors is no longer guaranteed. Ensure that the metals are separated by suitable underlays.

**Caution!**  
**Collector damage!**  
In order to install flat collectors according to the installation manual, a qualified engineer is required.  
The installation should be performed only by qualified engineers.

### 3.1 Technical Guidance

The system must be installed in accordance with all relevant and applicable national regulations, and must be installed to suit site conditions.

Observe all national regulations, including:

- Working at Heights Regulations 2005
- Health and Safety at Work Act 1974
- Electricity at Work Regulations 1989
- IEE Wiring Regulations BS 7671
- Lightning protection requirements
- Equipotential bonding of electrical installations.

### 3.2 Related documents

The installation of the solar system must be in accordance with the relevant requirements of Health and Safety Document No. 635 (The Electricity at Work Regulations 1989), BS 7671 (IEE Wiring Regulations) and the Water Supply (Water Fitting) Regulations 1999, or The Water Bylaws 2000 (Scotland). It should also be in accordance with the relevant requirements of the Local Authority, Building Regulations, The Building Regulations (Scotland), The Building Regulations (Northern Ireland) and the relevant recommendations of the following British Standards:

- BS EN 806: Specification for installations inside buildings conveying water for human consumption.

## 3 Safety information

- BS 6700: Services supplying water for domestic use within buildings and their curtilages.
  - BS 5449 Forced circulation hot water central heating systems for domestic premises.  
Note: only up to 45 kW.
  - BS 6880 Low temperature hot water heating systems of output greater than 45 kW.  
Part 1 Fundamental and design considerations.  
Part 2 Selection of equipment.  
Part 3 Installation, commissioning and maintenance.
  - BS 6114: Expansion vessels using an internal diaphragm for unvented hot water supply systems
  - BS 4814 Specification for: Expansion vessels using an internal diaphragm, for sealed hot water heating systems.
- Unvented hot water systems must comply with building regulation G section 3.

### 3.3 Regulations for the prevention of accidents

When carrying out works such as solar installation work it is necessary to do so in a safe and workman like manner, taking due care of any aspects of the works that could result in injuries to person in or about the building as well as workers, passers by and the general public at large. To that end these works must conform, but not be limited to, the current regulations in force such as the following

- Health and Safety at Work act 1974
- Work at Height Regulations 2005.
- Electricity at Work Regulations 1989
- All necessary Building Regulations.

Work should be preceded by a risk assessment covering all aspects of health and safety risks, or training requirements that can reasonably be foreseen to be associated with the work. All scaffolding in the UK, other than prefabricated (zip-up) scaffold towers, must be designed and constructed by a vetted contractor, and have suitable kick boards, hand rails and where appropriate netting. Areas around the scaffolding should be zoned off and marked with suitable warning signs to a suitable distance to protect persons from falling objects. Workers should have available and use personal protective equipment as necessary. This would include equipment such as fall protection systems, safety gloves, goggles, dust masks as well as any specialised equipment that may be in use such as lifting and handling equipment.

The completed works shall comply with all necessary BS EN Standards and Codes of practice as well as Building control or planning requirements and be confirmed where necessary by notification to building control or the appropriate competence based notification body.

### 3.4 Lightning protection



#### Caution!

#### Damage from lightning!

**If the installation height is more than 20 m or if the collectors are projected above the roof ridge, electro-conductive components must be connected to a lightning protection device!**

### 3.5 Frost protection



#### Caution!

#### Damage due to frost!

**Under no circumstances should water on its own be in the collector if there is a danger of frost!**

**After pressurisation and flushing, the collectors may contain water residues.**

**Immediately fill the solar system with solar fluid. Check the fluid concentration with a frost protection tester. Water remaining in the solar circuit may dilute the fluid.**

## 4 Before installation

### 4.1 Safety information

Please note the following instructions before and during installation:



**Danger!**

**Risk of death from falls and falling objects!**  
**Observe the national regulations for working at heights.**  
**Wear the Vaillant safety belt (article number 302066).**



**Danger!**

**Danger of burning and scalding!**  
**In case of solar irradiation inside the units, collectors can reach 200 °C. Remove the sun protection film installed at the factory only after the solar energy system has been started up.**



**Caution!**

**Collectors may be damaged by incorrect storage!**  
**Always store the collectors in a dry place and protected from the elements.**

---

**Caution!**

**System error function due to air bubbles!**  
**To fill the system, use the fill trolley (article number 0020042548) to avoid air bubbles.**  
**Use the manual air vent installed on the collector field.**  
**Alternatively, install the Vaillant Solar automatic air vent (article number 302019) in the highest point of the system or the automatic de-aerator (article number 302418) in the solar circuit.**  
**Observe the relevant installation and operating manual.**

---

**Caution!**

**Danger of damaging internal components!**  
**The interior of the collector is vented by the opening integrated in the pipe penetration.**  
**Keep the vent opening clear for trouble-free operation.**

## 4 Before installation

### 4.2 Scope of delivery

- Check the mounting kit for completeness based on the illustrations and bills of materials.

#### 4.2.1 On-roof mounting

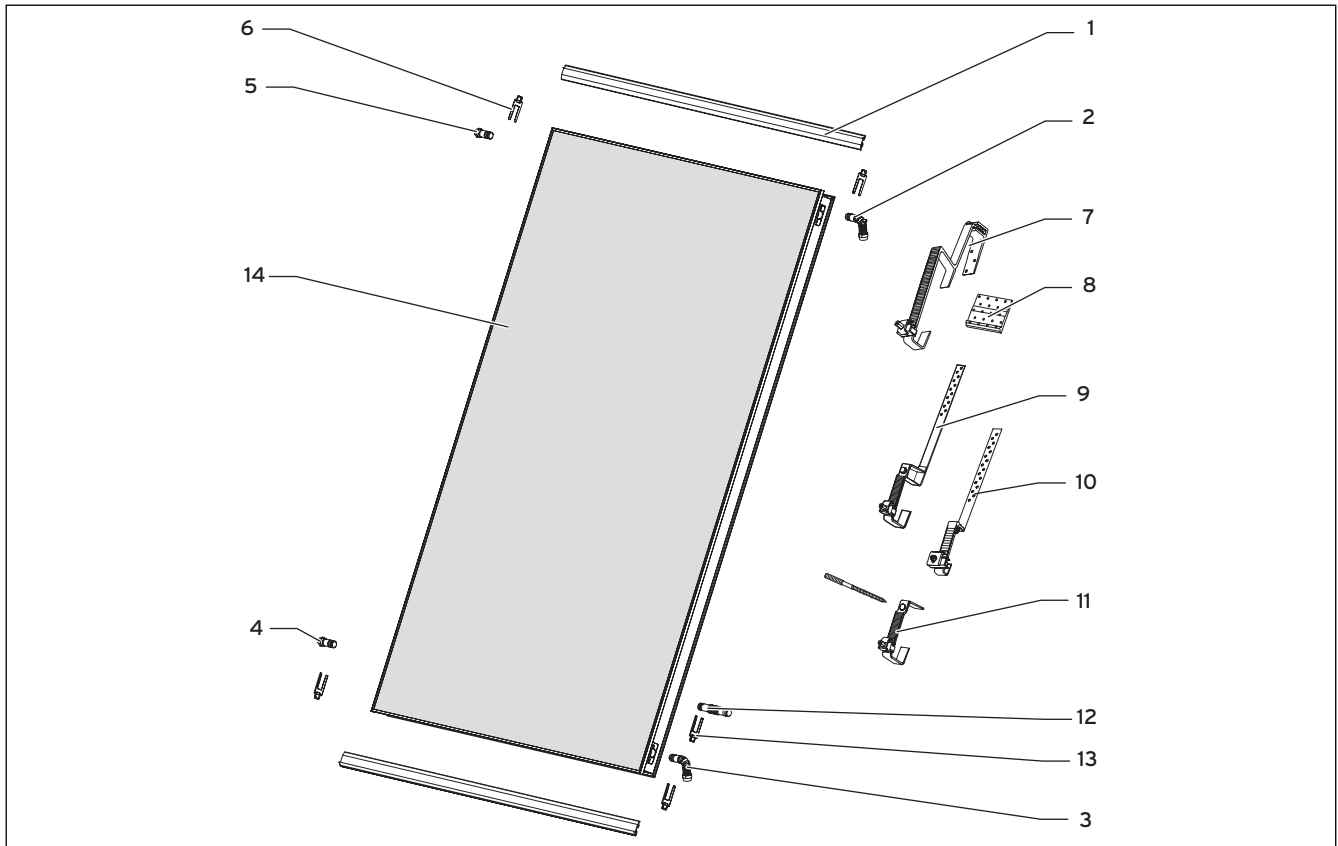


Fig. 4.1 On-roof mounting kit (here: vertical collector)

Pos.	Description	Quantity	Article number (kit)
1	Mounting rail	2	0020059899 (Vertical rail mounting kit) 0020059898 (Horizontal rail mounting kit)
2	Supply (outlet with opening for collector sensor)	1	0020059891 (Hydraulic connection kit)
3	Return (inlet)	1	
4	Lower plug	1	
5	Upper plug (with vent)	1	
6	Clamp	4	0020067273 (Basic kit) 0020067274 (Extension kit for stacked mounting)
7	Roof anchor type P (for pantile)	4	
8	Long lower section type P (optional)	1	0020080177
9	Roof anchor type S (for beaver tail, etc.)	4	0020067275 (Basic kit)
		2	0020067276 (Extension kit for stacked mounting)
10	Roof anchor type S flat (for beaver tail, etc.)	4	0020080145 (Basic kit)
		2	0020080147 (Extension kit for stacked mounting)
11	Stair bolt mounting kit	4	0020067277 (Basic kit)
		2	0020087855 (Extension kit for stacked mounting)
12	Hydraulic connections	2	0020055181 (Hydraulic extension kit)
13	Clamp	4	
14	Collector	1	0010004455 (auroTHERM VFK 145 V) 0010004457 (auroTHERM VFK 145 H) 0010006283 (auroTHERM VFK 150 V) 0010006285 (auroTHERM VFK 150 H)

Table 4.1 On-roof mounting bill of materials

4.2.2 Flat roof installation

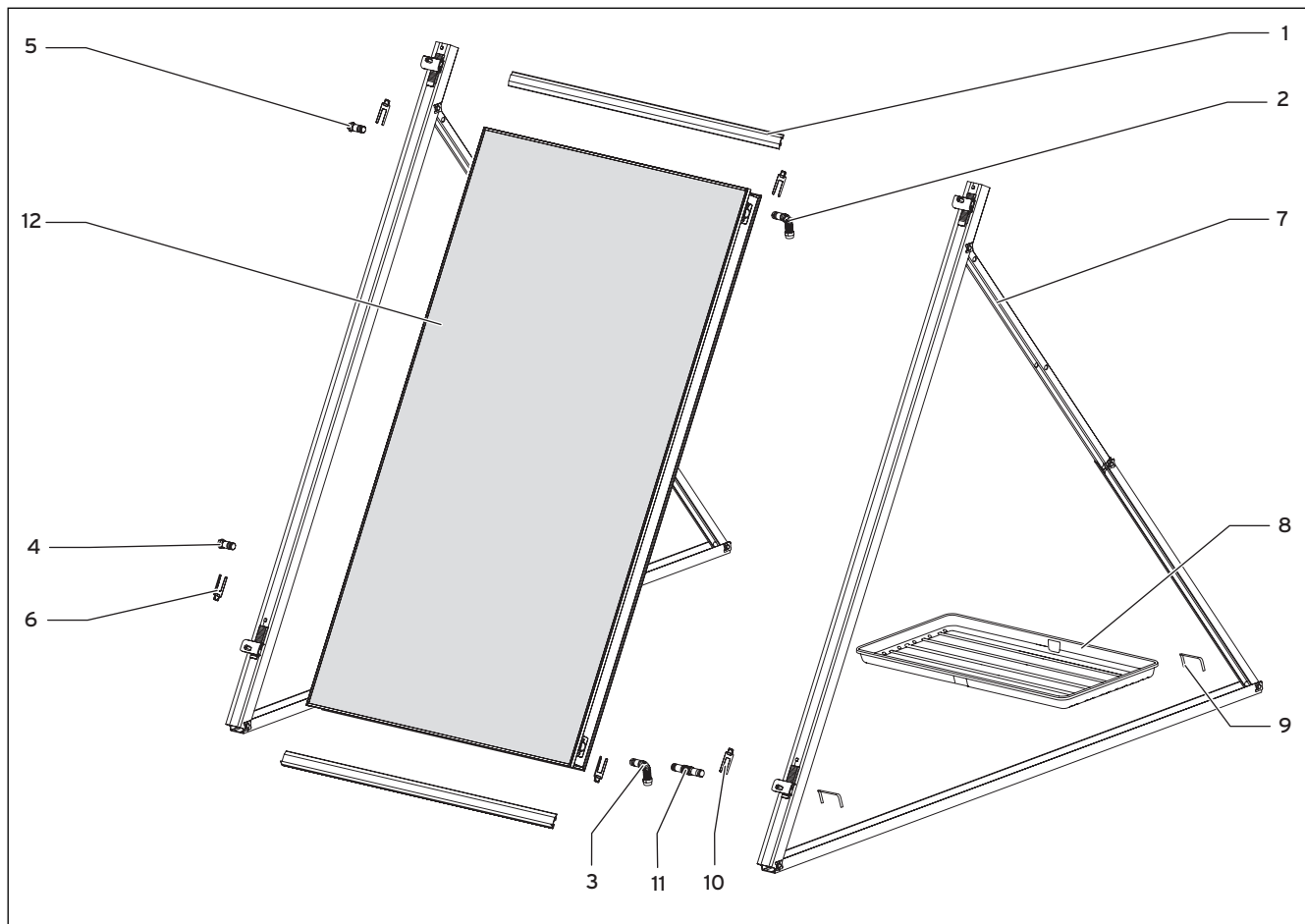


Fig. 4.2 Mounting kit for flat roof installation  
(here: vertical collector)

Pos.	Description	Quantity	Article number (kit)
1	Mounting rail	2	0020059901 (Vertical rail mounting kit) 0020059900 (Horizontal rail mounting kit)
2	Supply (outlet with opening for collector sensor)	1	0020059891 (Hydraulic connection kit)
3	Return (inlet)	1	
4	Lower plug	1	
5	Upper plug (with vent)	1	
6	Clamp	4	
7	Frame with clamping element	1	0020055206 (Base vertical frame kit) 0020055207 (Base horizontal frame kit)
8	Gravel tray (optional)	2 3	0020059904 (Gravel tray kit 2 pieces) 0020059905 (Gravel tray kit 3 pieces)
9	Safety clamps	2	0020055181 (Hydraulic extension kit)
10	Hydraulic connections	2	
11	Clamp	4	
12	Collector	1	0010004455 (auroTHERM VFK 145 V) 0010004457 (auroTHERM VFK 145 H) 0010006283 (auroTHERM VFK 150 V) 0010006285 (auroTHERM VFK 150 H)

Table 4.2 Flat roof installation bill of materials

## 4 Before installation

### 4.3 Collector field packaging

The following tables list the required components according to the type of installation.

#### On-roof mounting

		Number of collectors:										
		1	2	3	4	5	6	7	8	9	10	
Field arrangement side by side	Horizontal collector position	Hyd. connection kit article number 0020059891	1									
		Hyd. connection kit article number 0020055181	-	1	2	3	4	5	6	7	8	9
		Anchor set type P article number 0020067273										
		Anchor set type S article number 0020067275	1	2	3	4	5	6	7	8	9	10
		Anchor set type S flat article number 0020080145										
		Anchor set stair bolt Article number 0020067277										
		Horizontal rail, anodized - Article No. 0020059898	1	2	3	4	5	6	7	8	9	10
	Vertical collector position	Hyd. connection kit article number 0020059891	1									
		Hyd. connection kit article number 0020055181	-	1	2	3	4	5	6	7	8	9
		Anchor set type P article number 0020067273										
		Anchor set type S article number 0020067275	1	2	3	4	5	6	7	8	9	10
		Anchor set type S flat article number 0020080145										
		Anchor set stair bolt Article number 0020067277										
		Vertical rail, anodized - Article No. 0020059899	1	2	3	4	5	6	7	8	9	10
Field arrangement on top of each other	Horizontal collector position	Hyd. connection kit article number 0020059891	1	1	-	-	-	-	-	-	-	
		Hyd. connection kit article number 0020059894	-	1	-	-	-	-	-	-	-	
		Anchor set type P article number 0020055174										
		Anchor set type S article number 0020055184	1	1	-	-	-	-	-	-	-	
		Anchor set type S flat article number 0020080145										
		Anchor set stair bolt Article number 0020059897										
		Anchor extension kit type P article number 0020059896										
		Anchor extension kit type S article number 0020059895	-	1	-	-	-	-	-	-	-	
		Anchor extension kit type S flat article number 0020080147										
		Anchor extension kit hanger bolt anodised Item no. 0020087854										
	Horizontal rail, anodized - Article No. 0020059898	1	2	-	-	-	-	-	-	-		
	Vertical collector position *	Hyd. connection kit article number 0020059891	1	2	3	4	5	6	7	8	9	10
		Hyd. connection kit article number 0020059894										
		Anchor set type P article number 0020055174	1	1	1	1	1	1	1	1	1	
		Anchor set type S article number 0020055184										
		Anchor set type S flat article number 0020080145										
		Anchor set stair bolt Article number 0020059897										
		Anchor extension kit type P article number 0020059896	-	1	2	3	4	5	6	7	8	9
		Anchor extension kit type S article number 0020059895										
		Anchor extension kit type S flat article number 0020080147										
Anchor extension kit hanger bolt anodised Item no. 0020087854		1	2	3	4	5	6	7	8	9	10	
Vertical rail, anodized - Article No. 0020060379	1	2	-	-	-	-	-	-	-	-		

\* Caution!

When the vertical collector arrays are arranged on top of one another, the collectors must be hydraulically balanced with respect to one another (Tichelmann system).

Table 4.3 On-roof mounting components

**Flat roof installation**

		Number of collectors:										
		1	2	3	4	5	6	7	8	9	10	
Field arrangement side by side	Horizontal collector position	Gravel tray article number 0020059905	2	3	4	5	6	7	8	9	10	11
		Hyd. connection kit article number 0020059891	1									
		Hyd. connection kit article number 00 20055181	-	1	2	3	4	5	6	7	8	9
		Horizontal frame article number 0020055207	2	3	4	5	6	7	8	9	10	11
		Horizontal rail, aluminium article number 0020059900	1	2	3	4	5	6	7	8	9	10
	Vertical collector position	Gravel tray (3 pieces) article number 0020059905	2	4	4	6	8	8	10	12	12	14
		Gravel tray (2 pieces) article number 0020059904	1	0	2	1	0	2	1	0	2	1
		Hyd. connection kit article number 0020059891	1									
		Hyd. connection kit article number 0020055181	-	1	2	3	4	5	6	7	8	9
		Vertical frame article number 0020055206	2	3	4	5	6	7	8	9	10	11
		Vertical rail, aluminium article number 0020059901	1	2	3	4	5	6	7	8	9	10

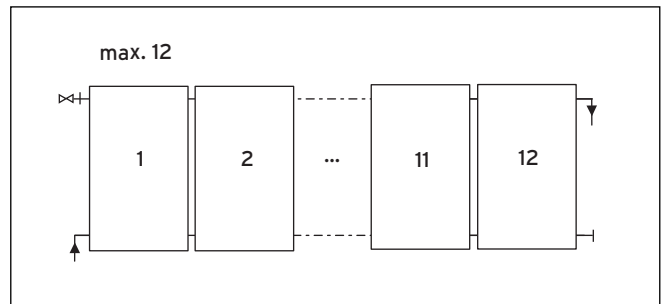
**Table 4.4 Flat roof installation components**

**4.4 Interconnection diagram**

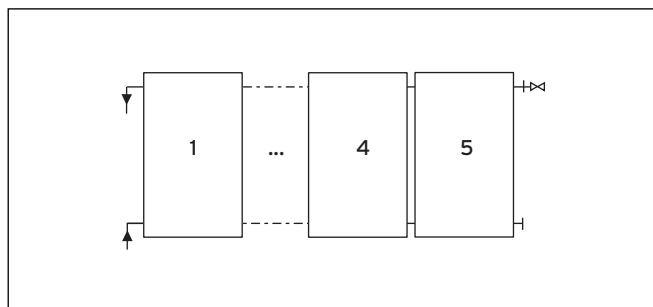
**Note**  
Observe the planning information when dimensioning the field volume flow.

**Field arrangement side by side**

**Note**  
If you connect 1 to 5 collectors one after another, the hydraulic connections can be laid one below the other on one side.

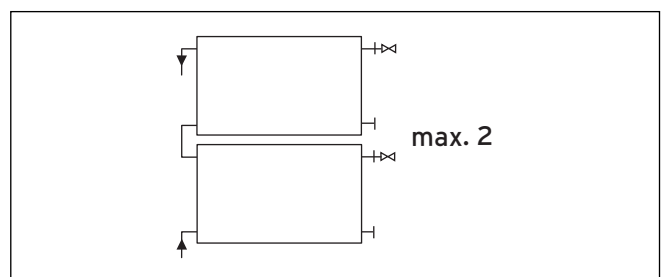


**Fig. 4.4 Field arrangement side by side for 6 - 12 collectors**



**Fig. 4.3 Field arrangement side by side for 1 - 5 collectors**

**Field arrangement on top of each other**



**Fig. 4.5 Field arrangement on top of each other**

**Note**  
If you connect 6 or more collectors one after another, the hydraulic connections must be arranged diagonally, to force a complete flow.

## 4 Before installation

### 5 Flat roof installation

#### 4.5 Hydraulic connection preparation

##### 4.5.1 On-roof mounting

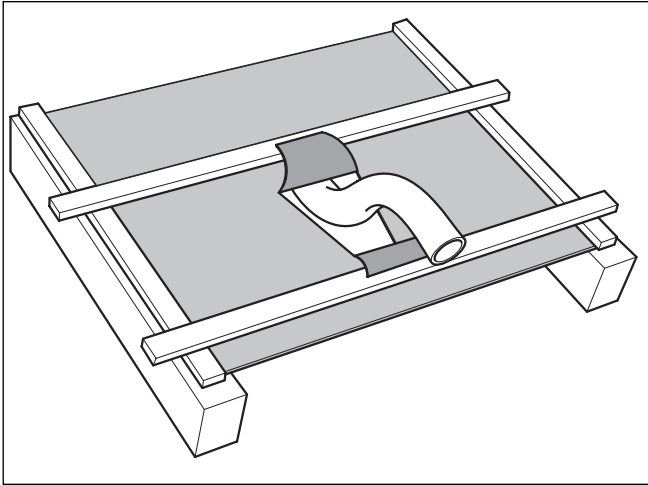


Fig. 4.7 Passing the pipe through the sarking membrane

If there is a sarking membrane, proceed as follows:

- Cut the sarking membrane vee-shaped.
- Fold the upper, larger tab on the roof batten above, and the lower, smaller tab on the roof batten below.
- Fix the sarking membrane tight to the roof batten. This ensure that the dampness flows away to the side.
- With the roofs activated, cut out a hole with the compass saw.
- Work the roofing felt as described for the sarking membrane.

##### 4.5.2 Flat roof installation



#### Caution!

**The roof skin can break and cause lack of tightness!**

**When installing the roof sealing surfaces, make sure the roof skin is adequately protected.**

- Place large protection mats under the system.
- If the frame is screwed directly, check the sealing of the building shell.

#### 4.6 Required tools

- For the installation of flat collectors, prepare the following tools.

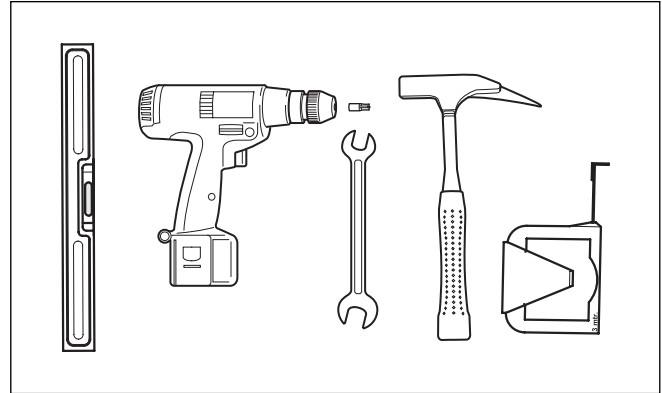


Fig. 4.8 Assembly tools: water level, cordless screwdriver, Torx bit (TX30, supplied), socket/combination wrench (SW 13), hammer, measuring tape / folding rule

## 5 Flat roof installation

With flat roof installation, flat collectors are fastened to frames.

The flat roof frames allow for a flexible installation with an angle of 30°, 45° or 60°.

Besides, the height of the mounting rails is variable, in order to compensate for small floor irregularities.

### 5.1 Collector position and field arrangement

Vaillant flat collectors are available in different versions: one for horizontal position, one for vertical position.

**Generally, the installation steps and the instructions described in this manual are valid for both collector positions.**

Any different installation steps are clearly pointed out:



**With horizontal collector position**



**With vertical collector position**



### 5.2 Weighting and arrangement of the frames

First of all, define the necessary load of the frames based on Tab. 5.1.

Load [kg/collector]

Angle of attack	Height above ground		
	0-10 m	10-18 m	18-25 m
30°	159	178	197
45°	225	252	279
60°	276	309	342

Table 5.1 Flat roof installation load



**Caution!**  
Starting from an installation height of 25 m above ground, a specific static calculation must be made!



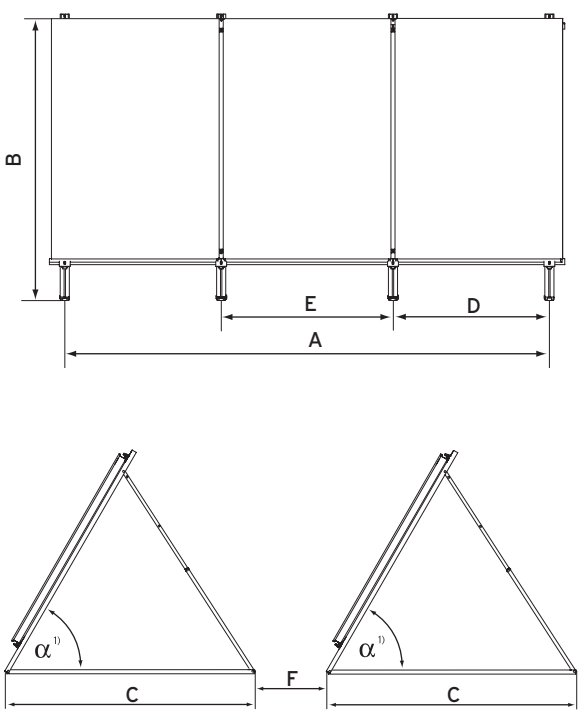
**Caution!**  
The roof may collapse!  
Before installation, check the maximum roof load!  
If necessary, call a technician.



**Caution!**  
For determining the installation location, keep a distance of 1 m from the roof edge! A different distance causes high wind loads.

For the required space and the distances among frames please see Tab. 5.2.

Number of collectors	A*	30°		45°		60°		C	D*	A
		B	F	B	F	B	F			
1**	1136									
2	2300									
3	3563									
4	4826									
5	6089									
6	7352									
7	8615									
8	9878									
9	11141									
10	12404									
1	1650									
2	3900									
3	5963									
4	8026									
5	10089									
6	12152									
7	14215									
8	16278									
9	18341									
10	20404									



\* Dimension A can vary by +/- 50 mm in connection with dimension D.  
 \*\* Possible only with 4 offset gravel trays.  
 1) Angle of attack (30°, 45° or 60°)

Table 5.2 Distances among frames

# 5 Flat roof installation

## 5.3 Collector installation

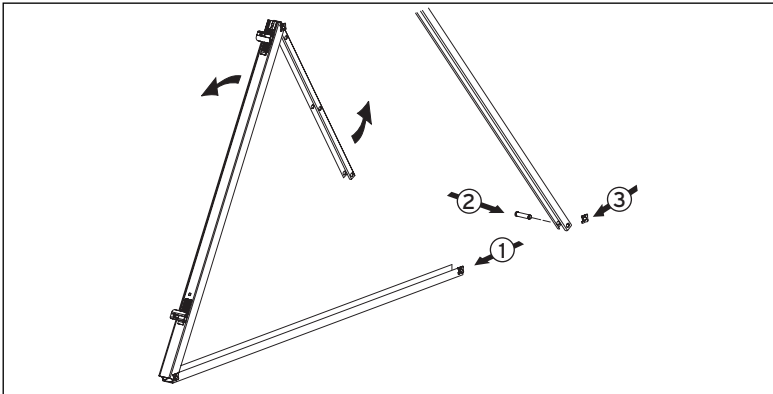


Fig. 5.2 Preparing the frame

- Open the frames.

**Caution!**  
Observe Table 5.1 for determining the required load!

**With screwed connection on the roof**

- Fix the lower telescopic section with bolt and safety clip.

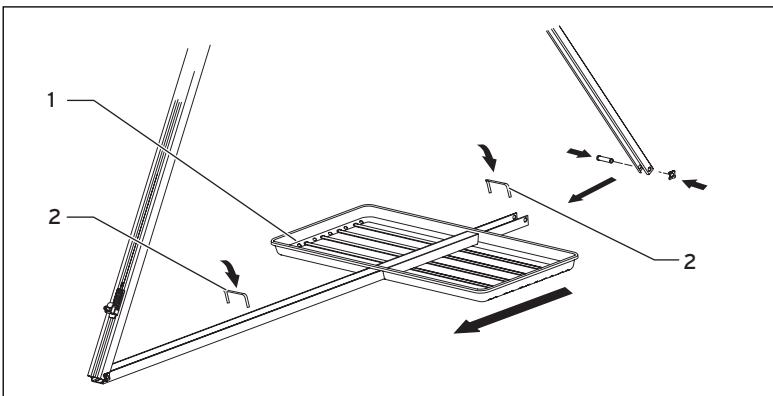


Fig. 5.3 Mounting the gravel trays

**If gravel trays are used:**

- Slide the gravel tray (1) on the floor section.

Collector position	Number of gravel trays per frame
	3
	4

Table 5.3 Number of gravel trays

- Apply the safety clamps (2) from the top in the floor sections (2 x frame) to fix the gravel tray.
- Fix the lower telescopic section with bolt and safety clip.
- Insert the telescopic sections into each other, until the holes of the desired angular position are placed one above the other.

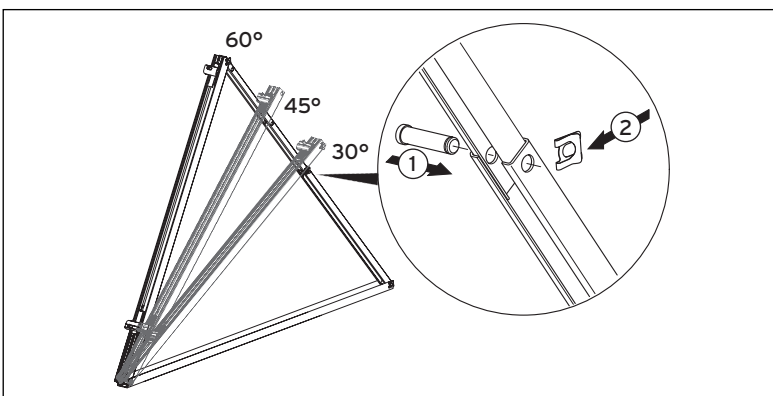


Fig. 5.4 Frame assembly

**Note**  
You can choose 30°, 45° or 60° (standard: 45°).

- Insert the retaining pin into the corresponding hole (1).
- Fix the retaining pin with the safety clip (2).

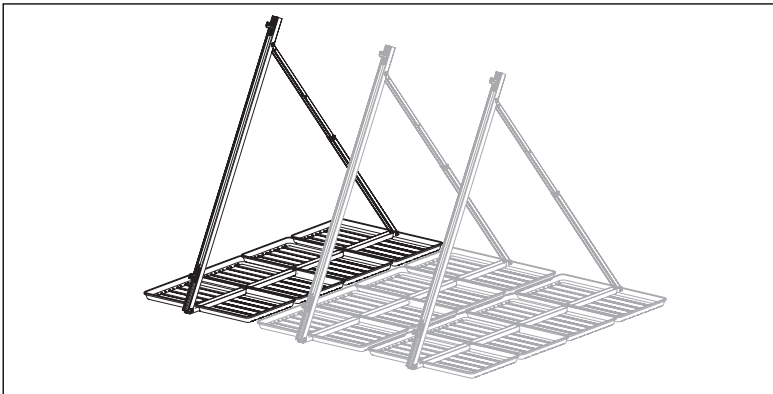


Fig. 5.5 Frames with gravel trays

**If gravel trays are used:**

- Place large protection mats under the system.
- Assembly frames based on the number of collectors to be installed.



**Caution!**

**Before mounting the collectors, fill the gravel trays on the first frame with gravel or other suitable weighting material, to give the system stability.**



**Note**

**For load weights and distances, please see Tab. 5.1 and 5.2.**

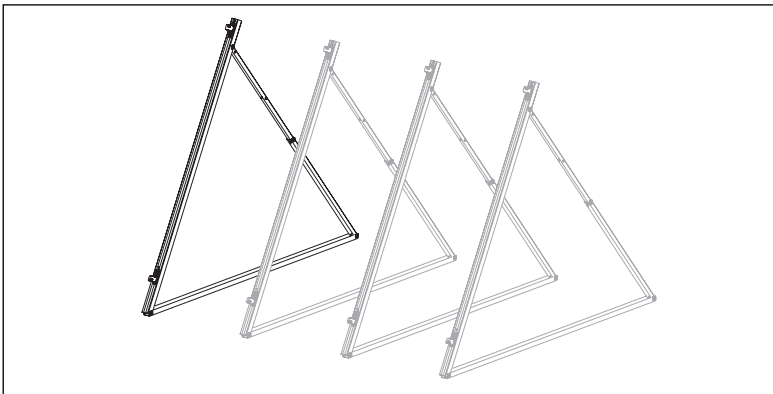


Fig. 5.6 Direct screwed connection

**With screwed connection to the flat roof:**

- Assembly frames based on the number of collectors to be installed.



**Note**

**For load weights and distances, please see Tab. 5.1 and 5.2.**

- Fix the frames on the roof.



**Caution!**

**The roof skin can break and cause lack of tightness! When installing the roof sealing surfaces, make sure the roof skin is adequately protected.**

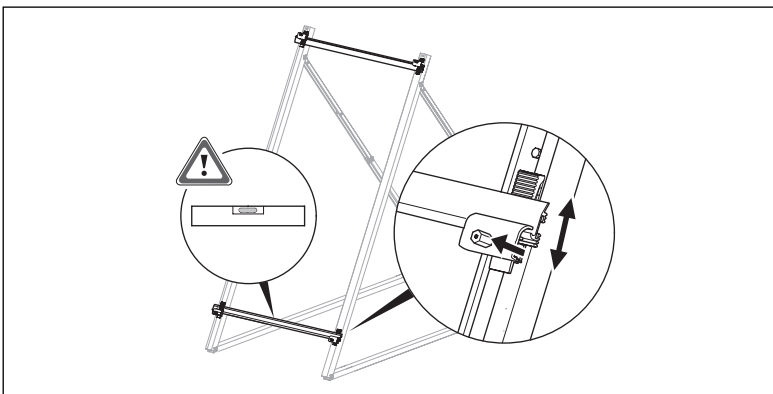
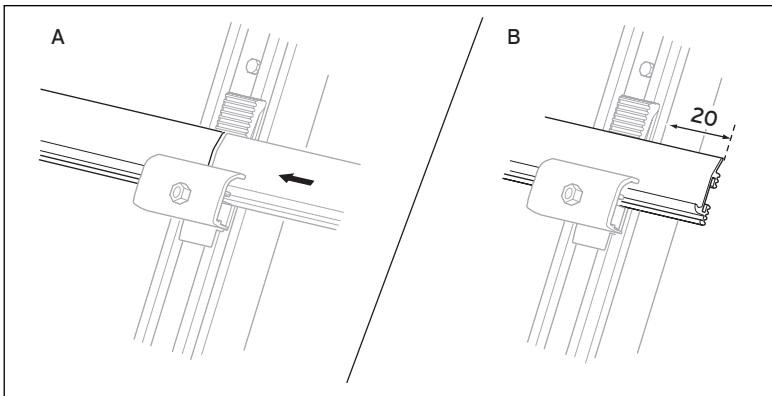


Fig. 5.7 Fixing and blocking the mounting rail

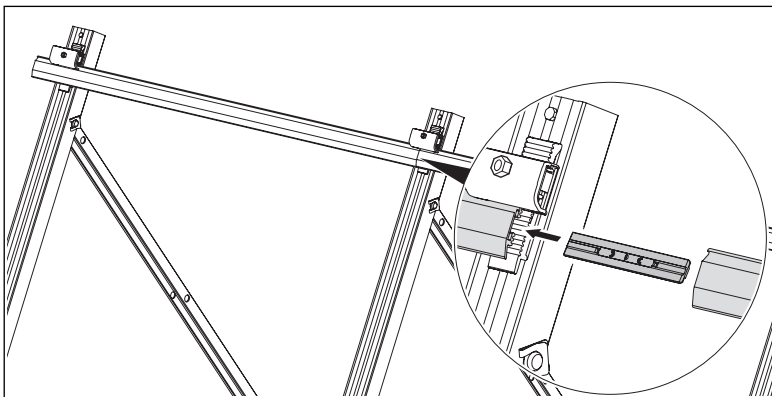
- Fix the horizontal mounting rails to the frame clamping elements.
- Compensate any difference in height by moving the clamping elements.
- Pull the lower part of the clamping element upward, now it can be moved and it engages again when released.

## 5 Flat roof installation



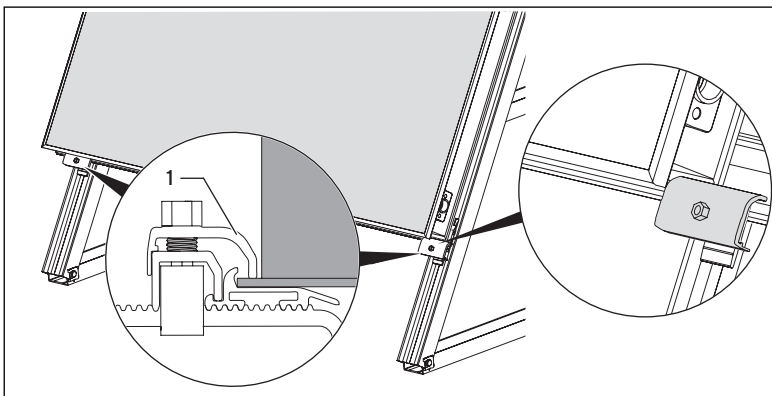
**Fig. 5.8 Positioning the mounting rails**

- If multiple collectors are mounted, the mounting rails meet in the centre of the clamping elements (**A**).
- On the first and last frame, the mounting rails can be projected by 20 mm (**B**).



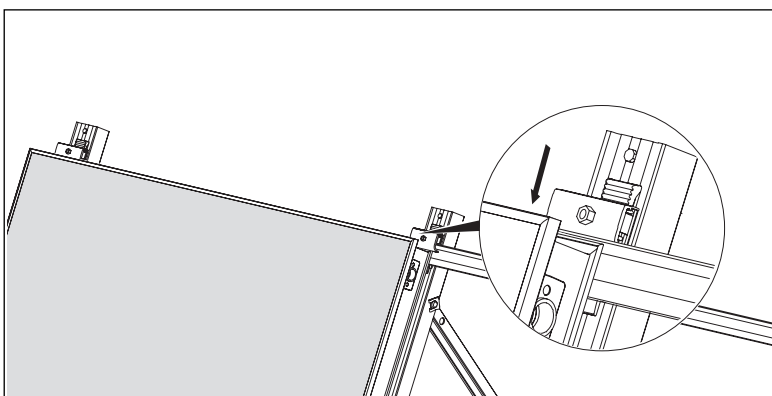
**Fig. 5.9 Joining the mounting rails**

- Insert the connecting elements into the mounting rails by the side.
- Position another frame (see Fig. 5.2 to 5.4).
- Join the mounting rails and fix them to the frame clamping elements.
- Compensate any difference in height by moving the clamping elements.



**Fig. 5.10 Hooking the collector**

- Place the collector with the lower edge in the section of the mounting rail.
- Make sure that the upper part (**1**) of the clamping element is above the collector edge.



**Fig. 5.11 Positioning the upper mounting rail**

- Slide the upper mounting rail until it flushes with the collector.
- Make sure that the upper part of the clamping element is above the collector edge.
- Tighten the lower clamping elements with the socket/combination wrench (SW 13).

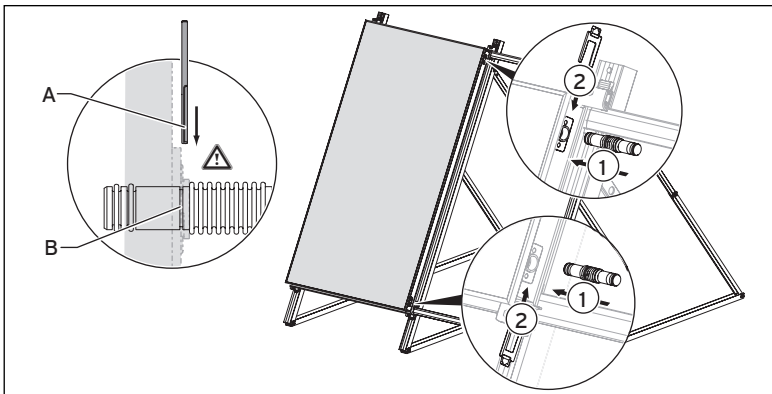


Fig. 5.12 Attaching the pipe coupling

- Remove the plugs from the openings.
- Insert the pipe couplings into the opening up to the stop (1).
- Slide the clamp in the rail of the opening (2).

**Caution!**  
**Danger of damage to the collector as a result of incorrect assembly!**  
**Make sure that the clamp (A) slides into the slot on the pipe coupler (B).**

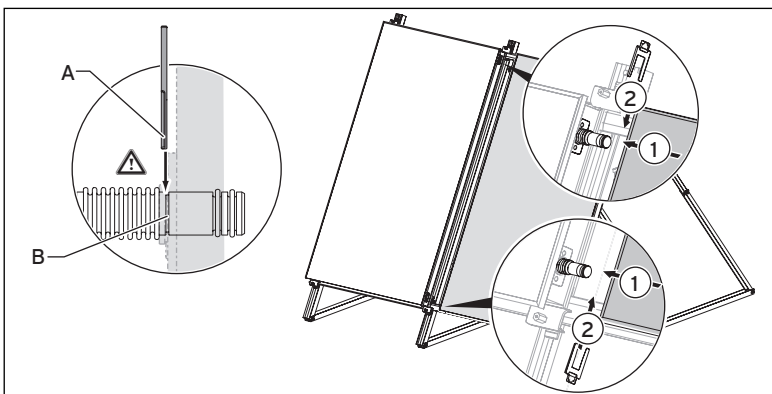


Fig. 5.13 Mounting other collectors

- Place the next collector on the lower mounting rail.
- Slide the collector on the first collector (1) and fix the hydraulic connectors with the clamps (2).
- Tighten both clamping elements of the first collector.

**Caution!**  
**Danger of damage to the collector as a result of incorrect assembly!**  
**Make sure that the clamp (A) slides into the slot on the pipe coupler (B).**

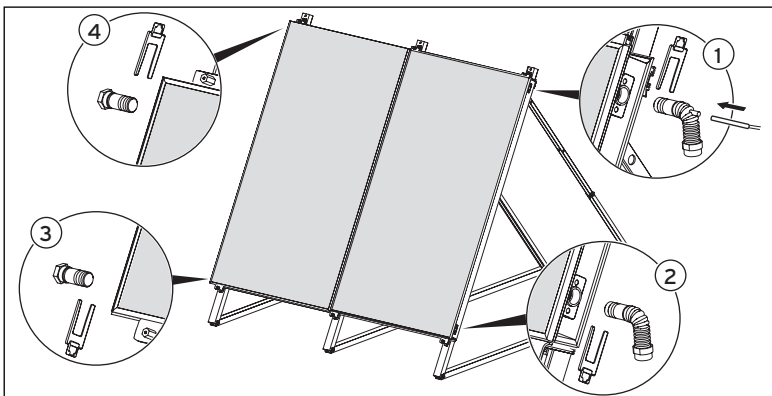


Fig. 5.14 Mounting the hydraulic connections (1 - 5 collectors)

- Connect the supply (outlet with opening for collector sensor) (1) on top.
- Remove the red plug and plug the collector sensor into the opening.
- Use a cable tie to prevent the collector sensor from slipping out.
- Connect the return (inlet) (2) at the bottom.
- Mount the plug without vent (3) in the lower part of the collector.
- Mount the plug with vent (4) in the highest position.
- Fix connections and plugs with the clamps.
- Connect the collector supply and return to the system with the connection pipes.
- If necessary check the connections for leaks.

## 5 Flat roof installation

### 6 On-roof mounting

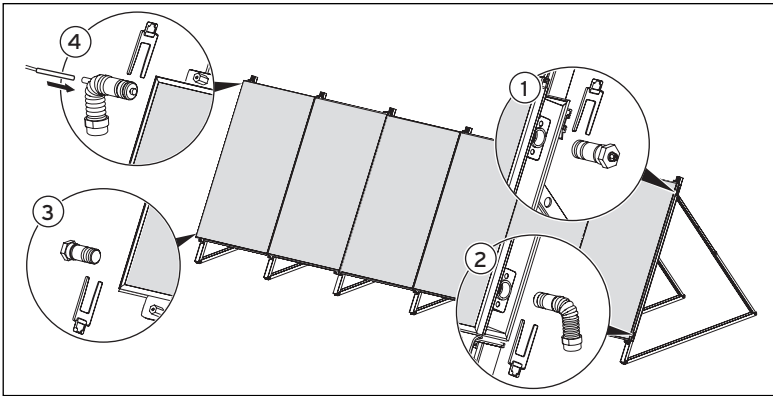


Fig. 5.15 Mounting the hydraulic connections (6 or more collectors)

**Note**  
 If you connect 6 or more collectors one after another, the hydraulic connections must be arranged diagonally, to force a complete flow.

- Insert the return (inlet) (2) into the lower side opening on one side and, diagonally across it, the supply (outlet with opening for collector sensor) (4) into the upper side opening.
- Remove the red plug and plug the collector sensor into the opening.
- Use a cable tie to prevent the collector sensor from slipping out.
- Mount the plug without vent (3) in the lower part of the collector.
- Mount the plug with vent (1) in the highest position.
- Fix connections and plugs with the clamps.
- Connect the collector supply and return to the system with the connection pipes.
- If necessary check the connections for leaks.

## 6 On-roof mounting

With on-roof mounting, flat collectors are fastened to horizontal mounting rails quickly and reliably with attachment clips. To ensure a good adaptation to the different roofings, three different roof anchors are available:





- Type P for standard tiles and bricks (e.g. pantile),
- Type S for flat shingles and tiles (e.g. beaver tail, slate) and extremely high protruding tiles (e.g. Mediterranean clay tiles)
- Stair bolt mounting kit for universal fixing (e.g. corrugated slabs, sheet with trapezoidal corrugations, shingles).

### 6.1 Collector position and field arrangement

Vaillant flat collectors are available in different versions: one for horizontal position, one for vertical position. Besides, they can be arranged in the collector field side by side and on top of each other.

**Generally, the installation steps and the instructions described in this manual are valid for both collector positions and field arrangements.**

Any different installation steps are clearly pointed out:

-  **With horizontal collector position**
-  **With vertical collector position**
-  **With fields arranged side by side**
-  **With fields arranged on top of each other**

6.2 Roof anchor installation



**Caution!**

**Risk of corrosion!**

On roofs made of metals more noble than aluminium (e.g. copper roofs) galvanic corrosion can occur at the anchor points, whereby the attachment of the collectors is no longer guaranteed. Ensure that the metals are separated by suitable underlays.

- First of all, define the required number of roof anchors based on Table 6.1.

Number of collectors	Elevation [m] up to	Number of anchors	Snow load zone									
			5		4		3		2		1	
			Roof angle from:									
			10°	40°	10°	40°	10°	40°	10°	40°	10°	40°
1	700		4	4	4	4	4	4	4	4	4	4
	900		4	4	4	4	4	4	6	4	6	4
	1200		4	4	4	4	6	4	8	6	8	6
2	700		8	8	8	8	8	8	8	8	8	8
	900		8	8	8	8	8	8	12	8	12	8
	1200		8	8	8	8	12	8	16	12	16	12
3	700		12	12	12	12	12	12	12	12	12	12
	900		12	12	12	12	12	12	18	12	18	12
	1200		12	12	12	12	18	12	24	18	24	18
4	700		16	16	16	16	16	16	16	16	16	16
	900		16	16	16	16	16	16	24	16	24	16
	1200		16	16	16	16	24	16	32	24	32	24
5	700		20	20	20	20	20	20	20	20	20	20
	900		20	20	20	20	20	20	30	20	30	20
	1200		20	20	20	20	30	20	40	30	40	30
6	700		24	24	24	24	24	24	24	24	24	24
	900		24	24	24	24	24	24	36	24	36	24
	1200		24	24	24	24	36	24	48	36	48	36
7	700		28	28	28	28	28	28	28	28	28	28
	900		28	28	28	28	28	28	42	28	42	28
	1200		28	28	28	28	42	28	56	42	56	42

Field of application according to EN 1991 T 1-3  
 Anchor Fmax: type S / type P 1.875 kN  
 Wind load: based on the design loads according to EN 1991 T 1-3, the following minimum distances among collectors must be respected:  
 1. The smallest value of 1/10 of the building length (eaves length) or 1/5 of the building height with respect to eaves and ridge.  
 2. The smallest value of 1/10 of the building width (gable width) or 1/5 of the building height with respect to side edges.  
 If extension kits are used, make sure that the roof hooks are positioned in the middle at equal distances. With an elevation above 900 HH [m] and roof angles below 40°, starting from snow load zone 2 a specific static calculation must be made.

Table 6.1 Number of required roof anchors

## 6 On-roof mounting

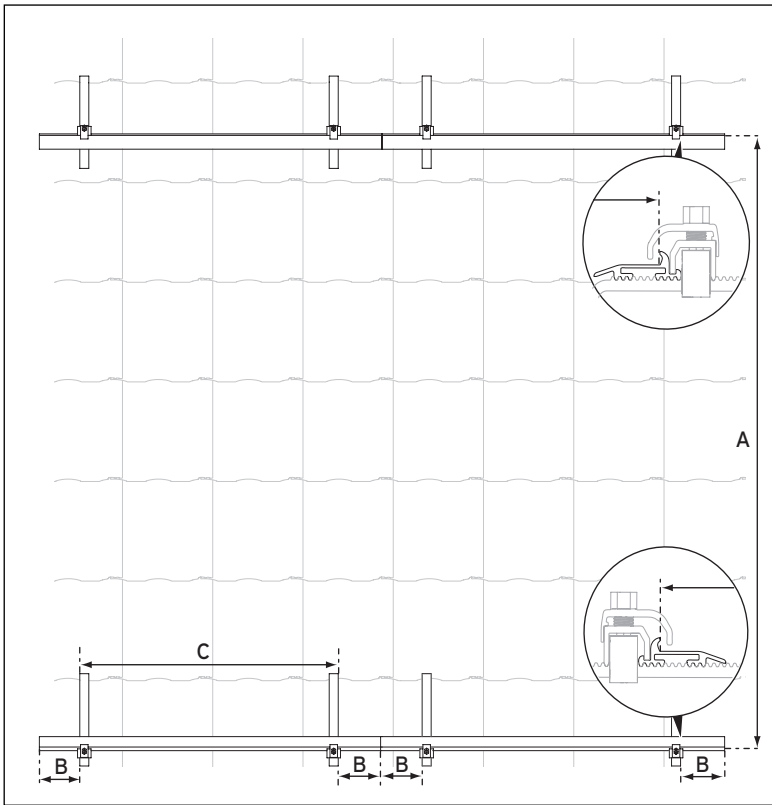




Fig. 6.1 Distances with field arrangement side by side



### With fields arranged side by side

- Mount the anchors for the mounting rails at the following distances:

		
A*	1245 / 1220	2045 / 2020
B	200 - 300	
C	1460 - 1660	660 - 860

\* Pre-assembly dimension / Finished dimension  
During final fixing of the collectors, the pre-assembly dimension is reduced by approx. 20 - 25 mm.

Table 6.2 Distances with fields arranged side by side



### Note

During final fixing the pre-assembly dimension is reduced by approx. 20 - 25 mm. Take care that there is adequate clearance on the anchors, therefore.

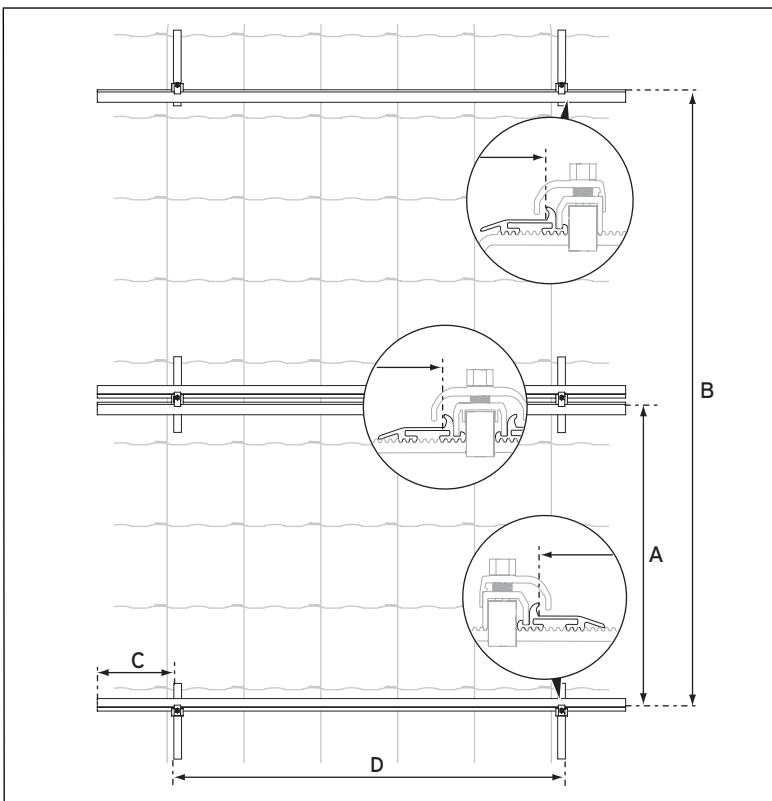


Fig. 6.2 Distances with field arrangement on top of each other



### With fields arranged on top of each other

- Mount the anchors for the mounting rails at the following distances:

	Distance in mm
A*	1245 / 1220
B*	2500 / 2480
C	200 - 300
D	1460 - 1660

\* Pre-assembly dimension / Finished dimension  
During final fixing of the collectors, the pre-assembly dimension is reduced by approx. 20 - 25 mm.

Table 6.3 Distances with field arrangement on top of each other



### Note

During final fixing the pre-assembly dimension is reduced by approx. 20 - 25 mm. Take care that there is adequate clearance on the anchors, therefore.



### 6.2.1 Roof anchor type P (pantile)

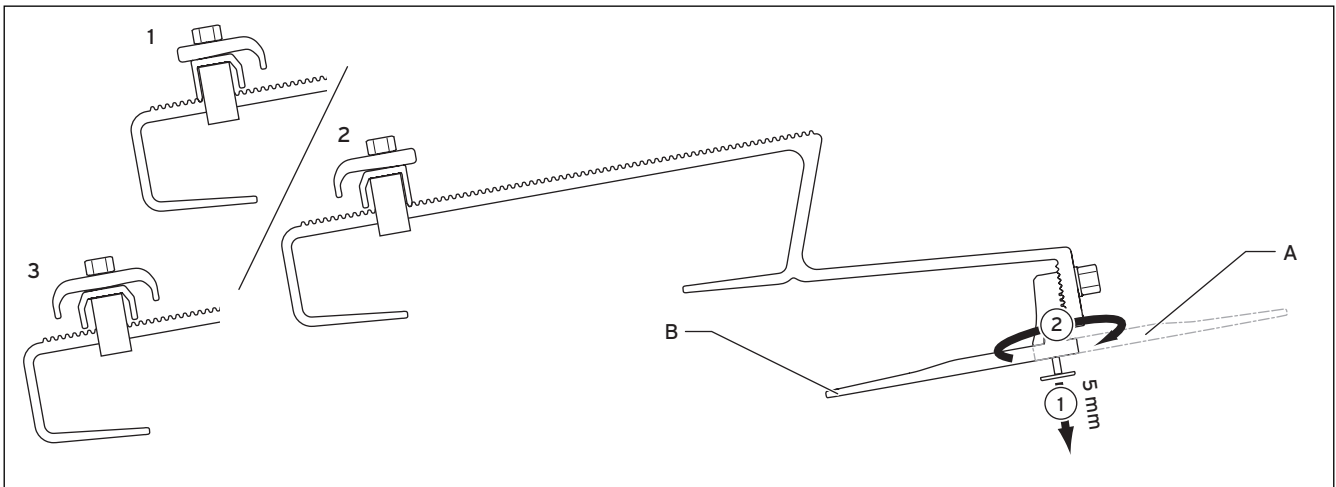


Fig. 6.3 Roof anchor type P

**Key**

- 1 Lower roof anchor
- 2 Upper roof anchor
- 3 Centre roof anchor

The roof anchor type P can be fixed to the **rafters** (Pos. A) or to the **roof batten** (Pos. B).

**Fixing to rafters**

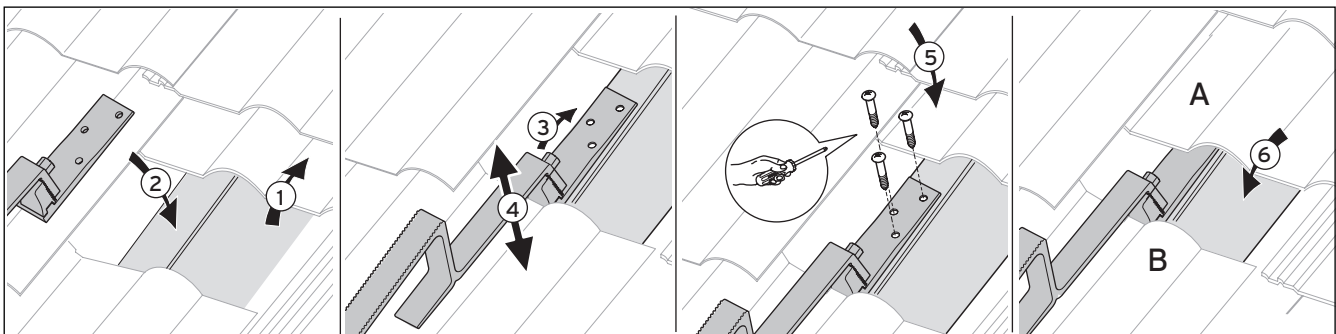


Fig. 6.4 Fixing to rafters

1. Uncover the rafters where needed. For distances please see Tab. 6.2 and 6.3.
2. Position the roof anchor. Pay attention to the correct position of the upper and lower roof anchor (see Fig. 6.3).
3. Loosen the upper bolt with the socket/combination wrench (SW 13) until the height of the roof anchor can be adjusted.
4. Position the roof anchor at the same height of the pantiles, so that the upper part of the anchor is on the roofing, and tighten the bolt with the socket/combination wrench (SW 13).
5. Screw the roof anchor to the rafters with the 3 supplied bolts.

6. Slide the pantiles back to the original position. If necessary, adapt the water gutter on the lower (A) or upper side (B) of the pantile with a hammer, until the pantiles are tight.



**Note**

With some types of roof it may be necessary to move the roof anchor to the side with respect to the rafters.

Use the „long lower section“ accessory, Part No. 0020080177 (not available in all countries).

Observe the associated assembly instructions.

## 6 On-roof mounting

### Fixing to the roof batten

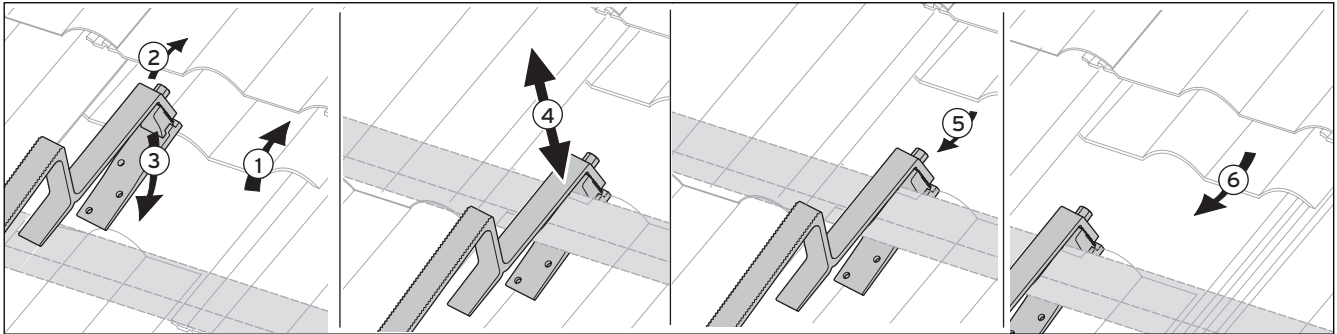


**Caution!**

**The roof may collapse!**

**Before installation on the roof batten, check the load capacity of the roof batten!**

**Replace the roof batten if necessary.**



**Fig. 6.5 Fixing to the roof batten**

1. Slide upward one or two pantiles above the roof batten. For distances please see Tab. 6.2 and 6.3.
2. Loosen the upper bolt with the socket/combination wrench (SW 13) until the height of the roof anchor can be adjusted.
3. Hook the roof anchor to the roof batten. Pay attention to the correct position of the upper and lower roof anchor (see Fig. 6.3).
4. Position the roof anchor at the same height of the pantiles. The upper part is on the roofing, the lower part is pressed tight against the roof batten from the bottom.  
Take care anchor is tightly fixed and pre-tensioned on the roof batten (toothing engaged).
5. Tighten the bolt with the socket/combination wrench (SW 13).
6. Slide the pantiles back to the original position.  
If necessary, adapt the water gutter on the lower side of the pantile with a hammer, until the pantiles are tight.

### 6.2.2 Roof anchor type S and roof anchor type S flat (for beaver tail)



#### Caution!

The roof may collapse!

Before installation on the roof batten, check the load capacity of the roof batten!

Replace the roof batten if necessary.

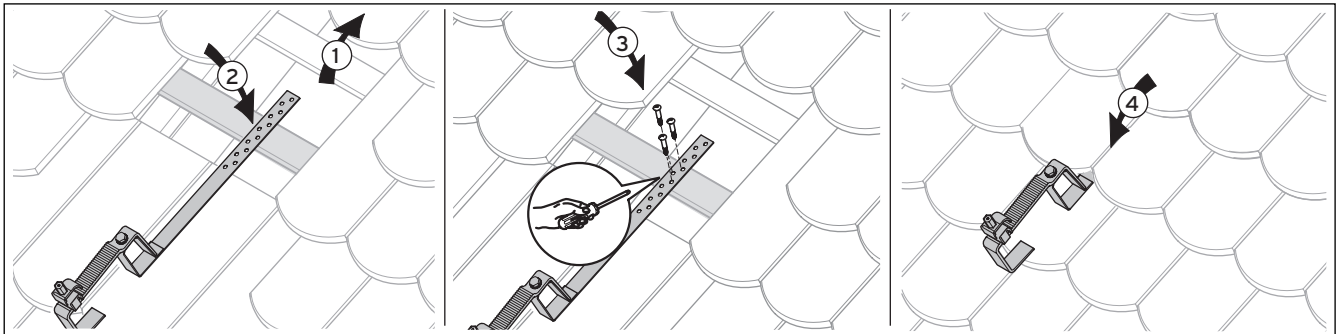


Fig. 6.6 Fixing the roof anchor type S

1. Uncover the rafters or the roof batten where needed. For distances please see Tab. 6.2 and 6.3.
2. Position the roof anchor. Pay attention to the correct position of the upper and lower roof anchor (see Fig. 6.3).
3. Screw the roof anchor to the rafters/roof batten with the 3 supplied bolts.
4. Slide the pantiles back to the original position.

## 6 On-roof mounting

### 6.2.3 Stair bolt mounting kit



#### Caution!

**Roof anchor type S and roof anchor type S flat (for beaver tail)**

**Before installation check the load-bearing capacity of the wooden substructure!**

**Reinforce the wooden substructure if necessary.**

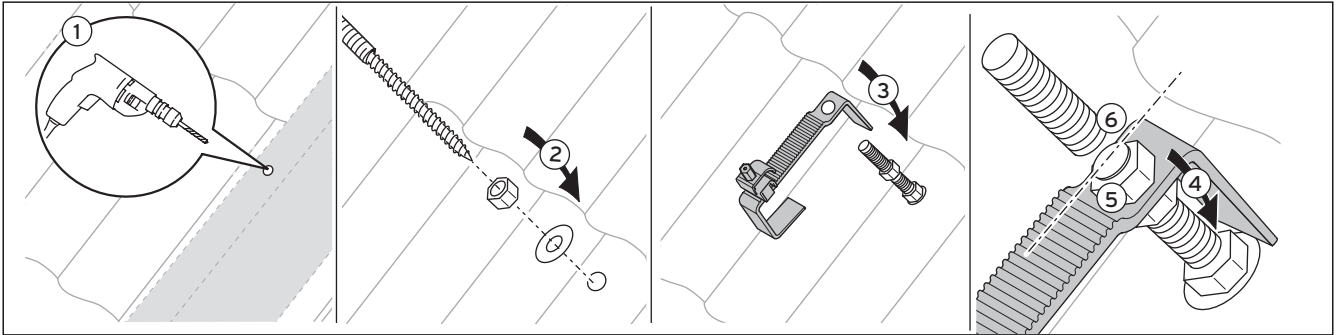


Fig. 6.7 Fixing with stair bolt

1. Bore a hole in the pantiles in the corresponding position. For distances please see Tab. 6.2 and 6.3.
2. Tighten the stair bolt to the rafters through the pantile.
3. Screw the lower nut against the pantiles, and tighten it until the seal sufficiently seals the opening.
4. Position the central nut so that after inserting the anchor upper part the front contact area is on the roofing. Pay attention to the correct position of the upper and lower roof anchor (see Fig. 6.3).
5. Screw the second nut and tighten it (SW 17).
6. Detach the threaded bolt directly above the nut. Deburr the interface.

### 6.3 Collector installation

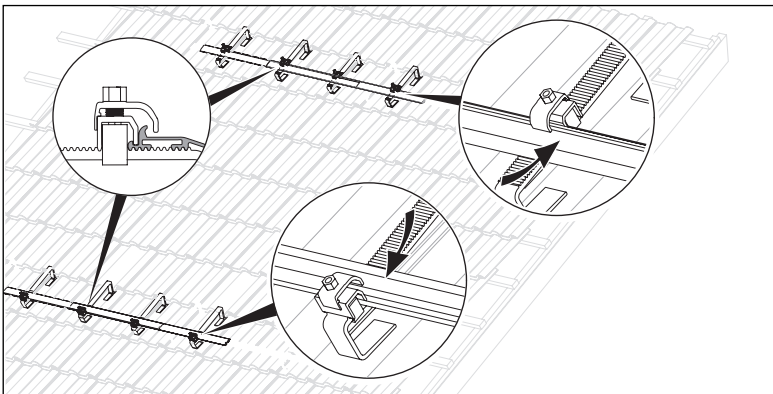


Fig. 6.8 Fixing the mounting rails

- Fix the horizontal mounting rails with the frame clamping elements on the roof anchors.



#### Note

**For the vertical spacing between the roof anchors please see Tab. 6.2 and 6.3.**



#### Note

**For a better visual appearance, position the lower rail as low as possible on the roof anchor.**

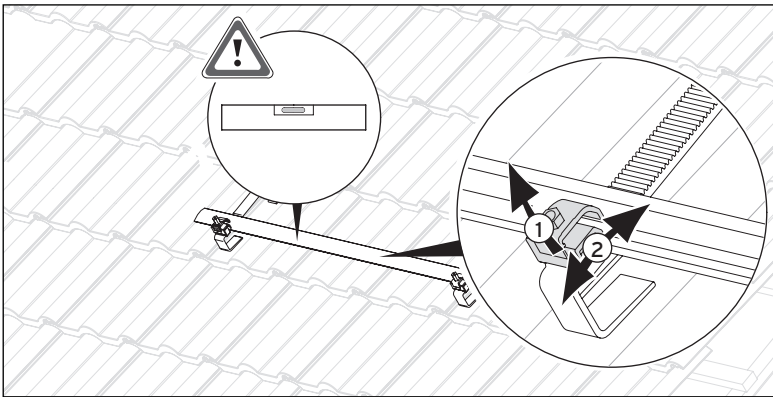


Fig. 6.9 Balancing the mounting rails

- Make sure that the mounting rails are fixed in horizontal position.
- Compensate any difference in height by moving the clamping elements.
- Pull the clamping element upward, now it can be moved and it engages again when released.

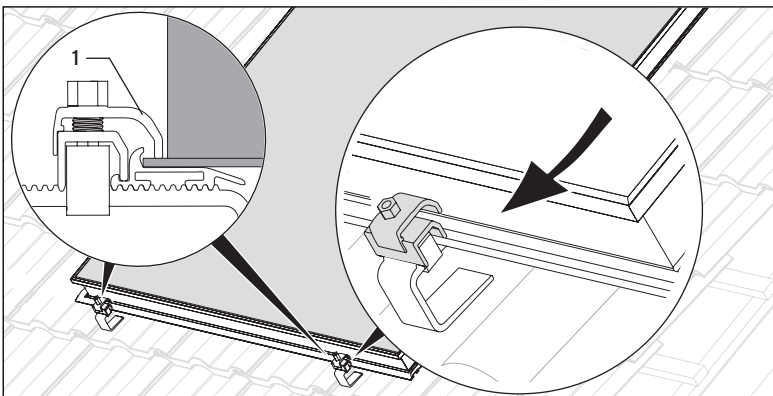


Fig. 6.10 Hooking the collector

- Place the collector with the lower edge on the mounting rail and hook it to the clamping elements.
- Make sure that the upper part (1) of the clamping element is above the collector edge.
- Tighten the clamping elements of the lower mounting rail with the socket/combi-nation wrench (SW 13).

**Caution!**  
**Danger of damage to the collector as a result of incorrect assembly!**  
**After tightening the clamping elements, make sure the tension is correct by shaking the upper part of the clamping element. If it can be moved, retighten the nut.**

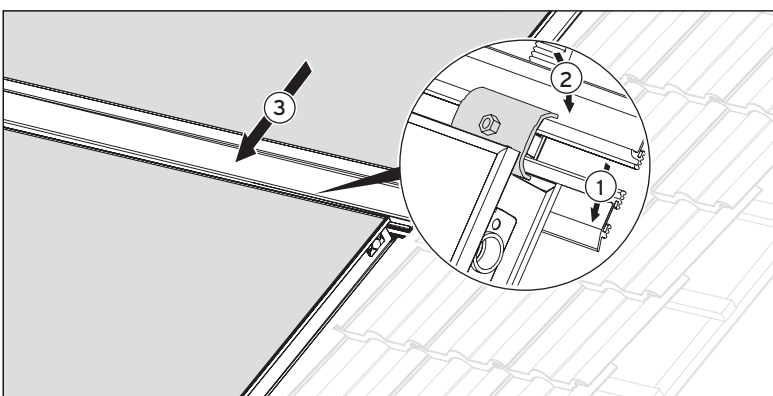


Fig. 6.11 Central mounting rail (field arrangement on top of each other)

**With fields arranged on top of each other**

- Slide the central mounting rail until it flushes with the lower collector (1).
- Make sure that the hook of the clamping element is above the collector edge.
- Fix the mounting rail (2) for the upper collector to the clamping element.
- Place the upper collector (3) in the central mounting rail.
- Screw the clamping elements of the central rail.

## 6 On-roof mounting

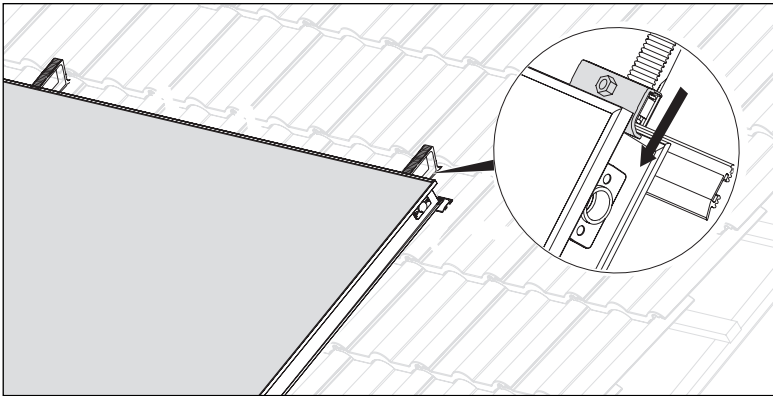


Fig. 6.12 Positioning the upper mounting rail

- Slide the upper mounting rail until it flushes with the lower collector.
- Make sure that the upper part of the clamping element is above the collector edge.
- Tighten the clamping elements above the collector.

**Caution!**  
**Danger of damage to the collector as a result of incorrect assembly!**  
**After tightening the clamping elements, make sure the tension is correct by shaking the upper part of the clamping element. If it can be moved, retighten the nut.**

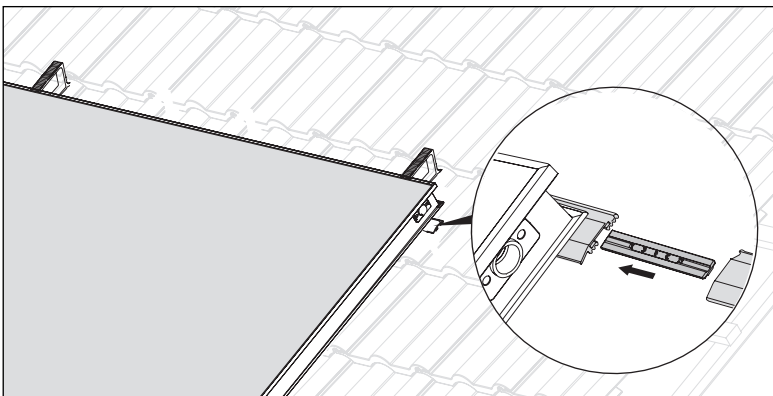


Fig. 6.13 Joining the mounting rails (field arrangement side by side)

- With fields arranged side by side**
- Insert the connecting elements into the mounting rails by the side, until they lock into place.
  - Join the mounting rails and fix them with the clamping elements on the roof anchors (see **Fig. 6.8**).
  - Compensate any difference in height by moving the clamping elements.

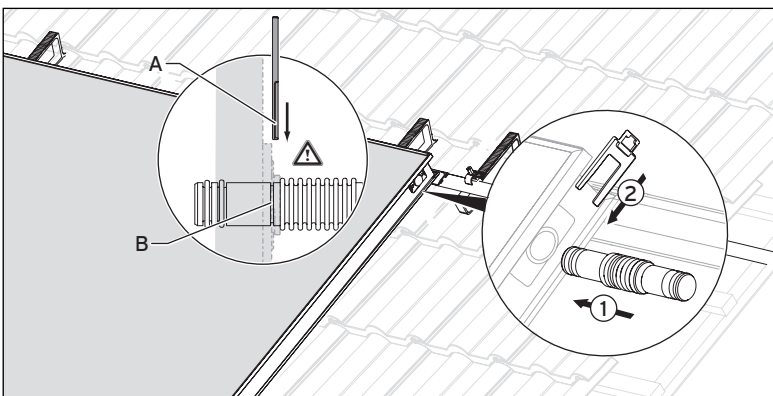


Fig. 6.14 Mounting the connectors (field arrangement side by side)

- With fields arranged side by side**
- Insert the hydraulic connectors **up to the end stop** into the corresponding openings on the side of the collectors.
  - Fix the connectors with the clamps, slide the clamps for the upper connection in the rail from the top, and then clamps for the lower connection from the bottom.

**Caution!**  
**Danger of damage to the collector as a result of incorrect assembly!**  
**Make sure that the clamp (A) slides into the slot on the pipe coupler (B).**

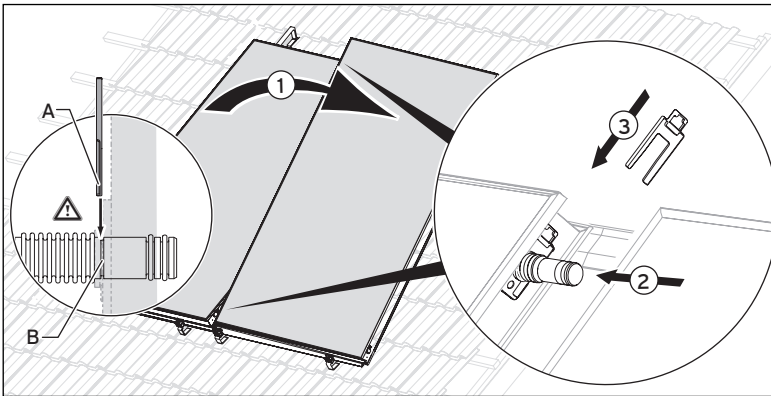


Fig. 6.15 Mounting other collectors (field arrangement side by side)

**With fields arranged side by side**

- Place the next collector (1) on the lower mounting rail.
- Slide the collector on the first collector (2), paying attention to the hydraulic connectors.
- Fix the hydraulic connectors inserted into the opening up to the limit stop with the clamps (3).
- Tighten all remaining clamping elements of the roof anchors.

**Caution!**  
**Danger of damage to the collector as a result of incorrect assembly!**  
**Make sure that the clamp (A) slides into the slot on the pipe coupler (B).**

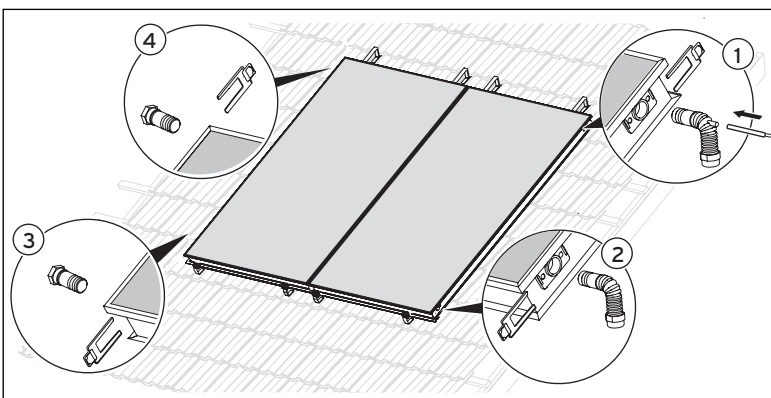


Fig. 6.16 Mounting the hydraulic connections (1 - 5 collectors)

**With fields arranged side by side**

- Connect the supply (outlet with opening for collector sensor) (1) on top.
- Remove the red plug and plug the collector sensor into the opening.
- Use a cable tie to prevent the collector sensor from slipping out.
- Connect the return (inlet) (2) at the bottom.
- Mount the plug without vent (3) in the lower part of the collector.
- Mount the plug with vent (4) in the highest position.
- Fix connections and plugs with the clamps.
- Connect the collector supply and return to the system with the connection pipes.
- If necessary check the connections for leaks.



## 6 On-roof mounting

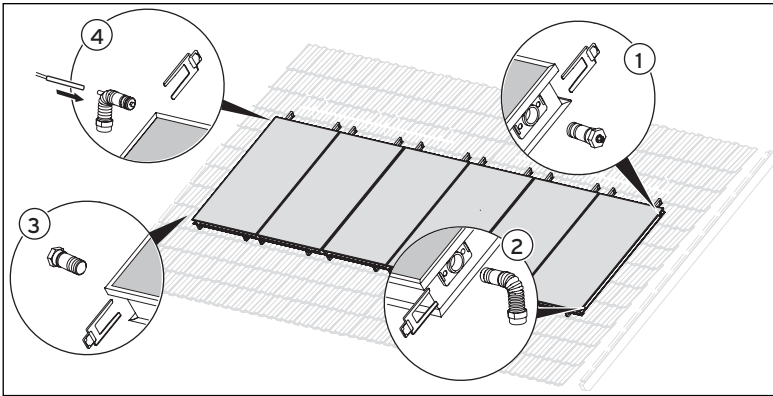


Fig. 6.17 Mounting the hydraulic connections (6 or more collectors)



With fields arranged side by side



### Note

If you connect 6 or more collectors one after another, the hydraulic connections must be arranged diagonally, to force a complete flow.

- Insert the return (inlet) (2) into the lower side opening on one side and, diagonally across it, the supply (outlet with opening for collector sensor) (4) into the upper side opening.
- Remove the red plug and plug the collector sensor into the opening.
- Use a cable tie to prevent the collector sensor from slipping out.
- Fix connections and plugs with the clamps.
- Mount the plug without vent (3) in the lower part of the collector.
- Mount the plug with vent (1) in the highest position.
- Connect the collector supply and return to the system with the connection pipes.
- If necessary check the connections for leaks.

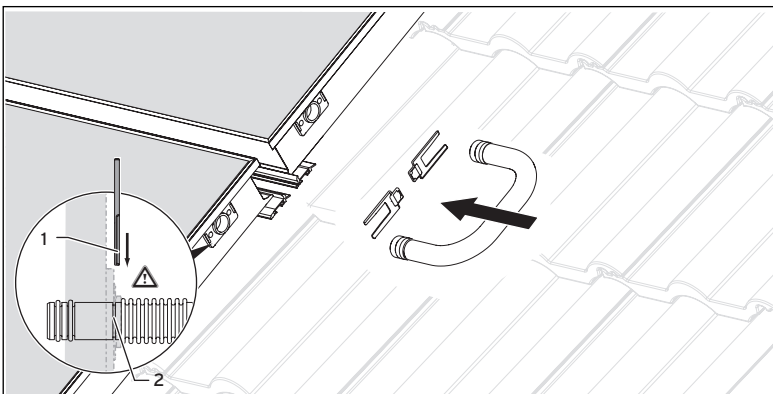


Fig. 6.18 Collector connection (fields arranged on top of each other)



With fields arranged on top of each other

- Join the collectors with the pipe coupling.
- Fix the pipe coupling with the clamps.



### Caution!

Danger of damage to the collector as a result of incorrect assembly! Make sure that the clamps (1) slide into the slot on the pipe coupler (2).




## 7 Concluding work

Based on the following table, make sure all work steps have been performed.

Step		
1	For flat roof installation: frames fixed with retaining pin and safety clip	
2	For flat roof installation: gravel trays filled/frames anchored	
3	All connections fixed with clamps	
4	Hydraulic connections laid correctly	
5	Collector sensor VR 11 connected	
6	All clamping elements tightened	
7	Collectors connected to lightning protection device (optional with lightning protection device)	
8	Pressure test (ideally with air pressure) carried out, all connections tight	

**Table 7.1 Final operations**

 **Note**  
After commissioning and in seasons when there are wide outside temperature fluctuations, condensate can form in the collector. This is normal.

 **Note**  
Reflections caused by irregularities of the glass are typical of the material.

## 8 Recycling and disposal

The raw materials used to manufacture the units and transport packaging are to a large extent recyclable. Please observe the applicable national legal regulations."

### 8.1 Collectors

The collectors must not be disposed of in the household waste.

All materials can be fully recycled, sorted according to their respective types and grades and brought to the local recycling facility. Make sure that the collectors are disposed of properly.

### 8.2 Packaging

The transport packaging will be disposed of by the expert technician who installs the units.

### 8.3 Solar fluid

The solar fluid must be disposed of in accordance with the local regulations, e.g. a suitable landfill site or incinerator plant.

Untaminated packaging can be reused. Dispose of packaging that cannot be cleaned in the same way as for solar fluid."

## 9 Vaillant Customer Service and warranty

### 9.1 Vaillant warranty

Vaillant provides a full parts and labour warranty for this appliance.

The appliance and all associated pipe work and controls must be installed by suitably competent persons in accordance with all current and relevant safety, building control and planning regulations and in full compliance with the manufacturer's instructions.

All unvented domestic hot water cylinders must be installed by a competent person to the prevailing building regulations at the time of installation (G3).

Terms and conditions apply to the warranty, details of which can be found on the warranty registration card included with this appliance.

Failure to install and commission this appliance in compliance with the manufacturer's instructions may invalidate the warranty (this does not affect the customer's statutory rights).

### 9.2 Vaillant Service

To ensure regular servicing, it is strongly recommended that arrangements are made for a Maintenance Agreement.

Please contact Vaillant Service Solutions (0870 6060 777) for further details.

## 10 Technical data

	Units	VFK 145 H/V	VFK 150 H/V
Absorber type		Serpentine horiz./vert.	
Dimensions (L x W x H)	mm	2033 x 1233 x 80 (V)	
		1233 x 2033 x 80 (H)	
Weight	kg	38	
Volume	l	2.16 (H) 1.85 (V)	
Max. pressure	bar	10	
Stagnation temperature	°C	171	172
Gross area	m <sup>2</sup>	2.51	
Aperture surface area	m <sup>2</sup>	2.35	
Absorber surface area	m <sup>2</sup>	2.33	
Absorber	mm	Aluminium (vacuum coated) 0.5 x 1178 x 1978	
Coating		High selective (blue)	
		$\alpha = 95\%$ $\epsilon = 5\%$	
Glass covering	mm	3.2 (thickness) x 1233 x 2033	
Glass type		Solar safety glass (prismatic structure)	Solar safety glass (anti-reflex coating)
Transmission	%	$\tau = 91$	$\tau = 96$
Back wall insulation	mm W/m <sup>2</sup> K kg/m <sup>3</sup>	40 $\lambda = 0.035$ $\rho = 55$	
Edge insulation		none	
Efficiency $\eta_0$	%	80.1 (H) 79.1 (V)	84.2 (H) 83.3 (V)
Heat capacity	Ws/m <sup>2</sup> K	9700 (H) 8200 (V)	
Heat loss factor ( $k_1$ )	W/m <sup>2</sup> K	3.32 (H) 2.41 (V)	3.82 (H) 2.33 (V)
Heat loss factor ( $k_2$ )	W/m <sup>2</sup> K <sup>2</sup>	0.023 (H) 0.049 (V)	0.018 (H) 0.049 (V)

Table 10.1 Technical data

VFK 145 H, VFK 150 H

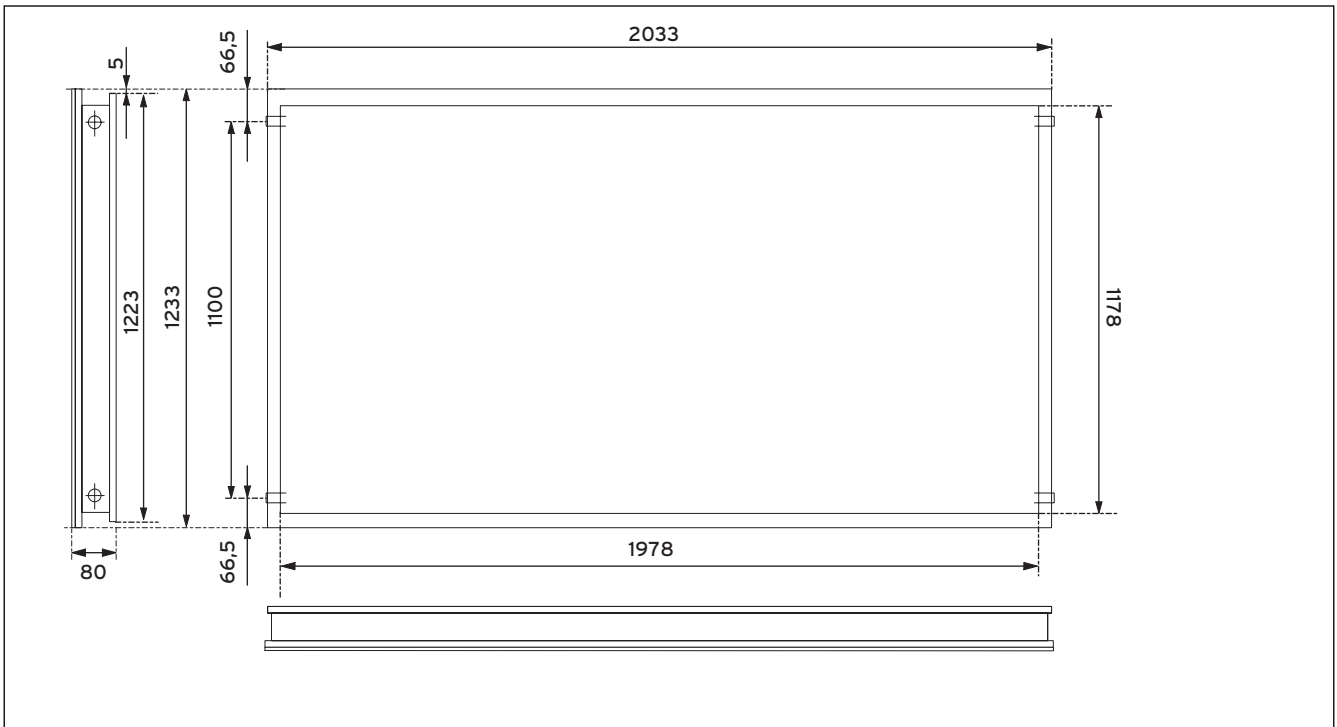


Fig. 10.1 Scale drawing VFK 145 H, VFK 150 H

VFK 145 V, VFK 150 V

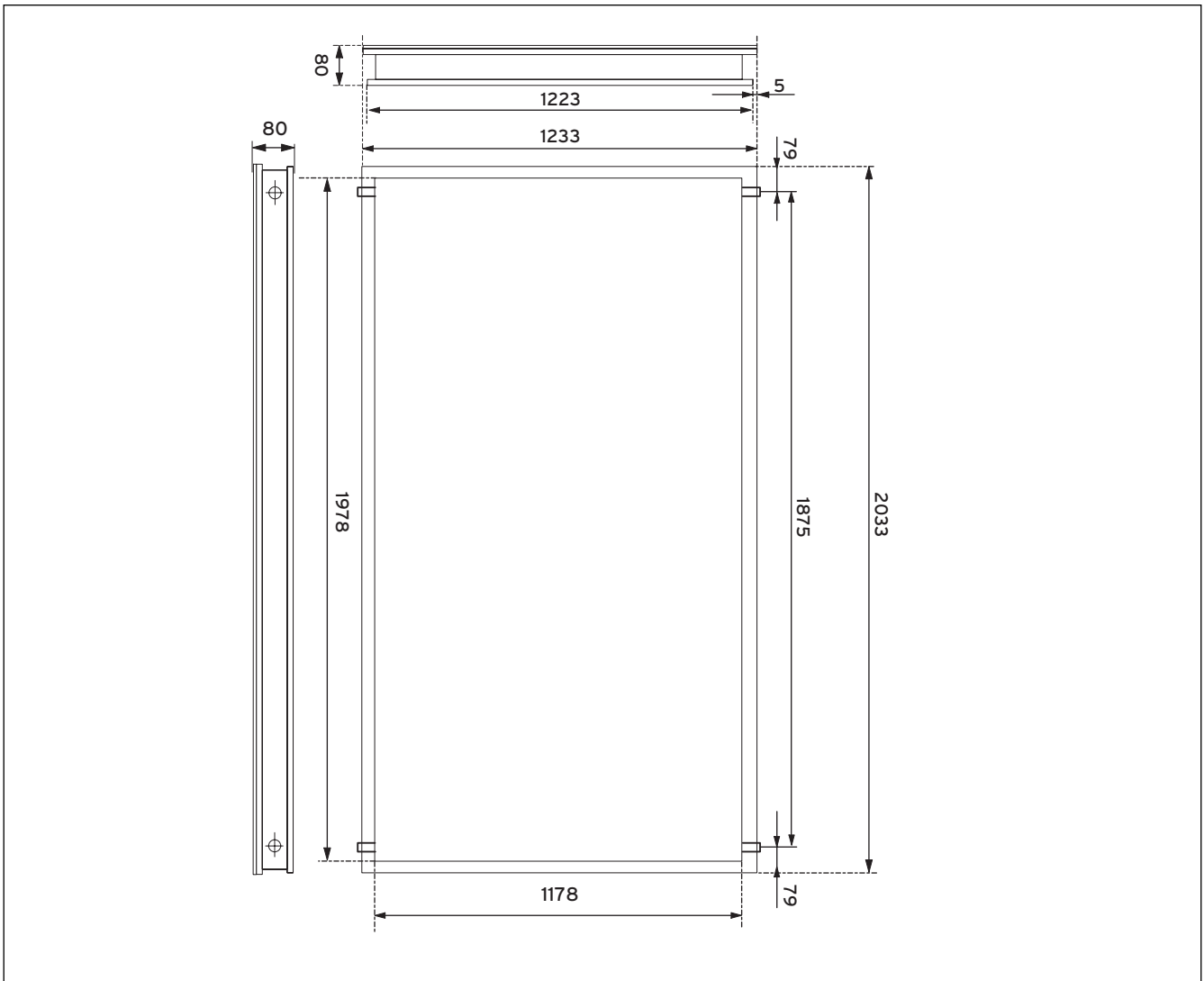


Fig. 10.2 Scale drawing VFK 145 V, VFK 150 V



**Sonur, Lda.**

Estrada da Luz, 173 R/C Esq. ■ 1600-154 Lisboa

Tel. +351 217 261 711 ■ Fax +351 217 261 547 ■ geral@sonur.pt ■ www.sonur.pt

**Vaillant BV**

Postbus 23250 ■ 1100 DT Amsterdam ■ Telefoon 020 / 565 92 00

Telefax 020 / 696 93 66 ■ www.vaillant.nl ■ info@vaillant.nl

**Vaillant Ltd**

Nottingham Road ■ Belper ■ Derbyshire ■ DE56 1JT

Telephone 0845 602 2922 ■ www.vaillant.co.uk ■ info@vaillant.co.uk

**Vaillant S. L.**

**Atención al cliente**

C/La Granja, 26 ■ Pol. Industrial ■ Apartado 1.143 ■ 28108 Alcobendas (Madrid)

Teléfono 902 11 68 19 ■ Fax 916 61 51 97 ■ www.vaillant.es

0020057143\_04 ESGBNLPT 092009 - Reservado el derecho a introducir modificaciones - Subject to alterations - Wijzigingen voorbehouden  
- Reservado o direito de introduzir modificações