

Data sheet

Seated valve (PN 16)

VFM 2 – 2-way valve, flange

Description



Valve for heating, district heating and district cooling systems.

VFM 2 valve can be used together with following Danfoss actuators:

- AMV(E) 655
- AMV(E) 658 SU/SD
- AMV(E) 659 SD
- AMV(E) 85/86 (for VFM 2 DN 150-250)

Features:

- Logarithmic characteristic
- Rangeability >100:1
- Pressure relieved design

Main data:

- DN 65-250
- k_{vs} 63-900 m³/h
- PN 16
- Medium: Circulation water / glycolic water up to 50%
- Temperature: 2 (-10*) ... 150 °C

* At temperatures from -10 °C up to +2 °C use stem heater

- Flange PN 16 connections
- Push-pull connection between valve and actuator
- Compliance with Pressure Equipment Directive 97/23/EC

Ordering

Valve VFM 2

Picture	DN	k_{vs} (m ³ /h)	PN	$\Delta p_s^{2)}$ (bar)	$\Delta p_{max.}$ (bar) ¹⁾ for AMV(E)65x	$\Delta p_{max.}$ (bar) ¹⁾ for AMV(E)85/86	Code No.
	65	63	16	16	8	-	065B3500
	80	100					065B3501
	100	160					065B3502
	125	250					065B3503
	150	400		10	4	10	065B3504
	200*	630		7	065B3505		
	250*	900		3	5	065B3506	

¹⁾ $\Delta p_{max.}$ is maximum permissible differential pressure across the valve referred for the whole actuating range of motorised valve (a function of actuator's performance)

²⁾ Δp_s is maximum permissible closing differential pressure applied in fully closed position of the valve, at which valve will seal tightly (close off pressure)

* For DN 200 in combination with AMV(E)85/86: k_{vs} is reduced by 15%
For DN 250 in combination with AMV(E)85/86: k_{vs} is reduced by 20%

Accessories

Type	DN	Code No.
Stem heater	65-125	065Z7020
	150-250	065Z7022

Service kits

Type	Code No.	
Top cover sealing set VFM 2	065B3528	
Stuffing box	DN 65-125	065B3529
	DN 150-250	065B3530

Technical data

Nominal diameter	DN	65	80	100	125	150	200	250
k_{vs} value	m ³ /h	63	100	160	250	400	630	900
Stroke	mm	30	34	40			50	
Rangeability		>100:1						
Control characteristic		Logarithmic						
Cavitation factor z		0,45	0,40	0,35			0,30	
Leakage acc. to standard IEC 534		< 0,03 % of k_{vs}						
Nominal pressure	PN	16						
Medium		Circulation water / glycolic water up to 50 % (standard VDI 2035)						
Medium pH		Min. 7, Max. 10						
Medium temperature	°C	2 (-10 ¹⁾ ... 150						
Connections		Flange PN 16 acc. to EN 1092-2						
Materials								
Valve body and cover		Grey cast iron EN-GJL-250 (GG 25)						
Valve seat, cone and spindle		Stainless steel						
Stuffing box sealing		EPDM						

¹⁾ At temperatures from -10 °C up to +2 °C use stem heater

Pressure temperature diagram

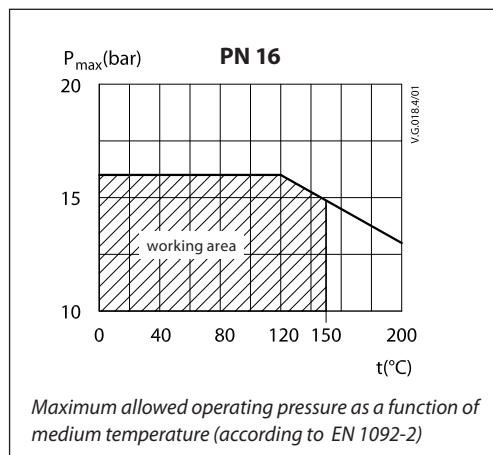

Valve characteristics

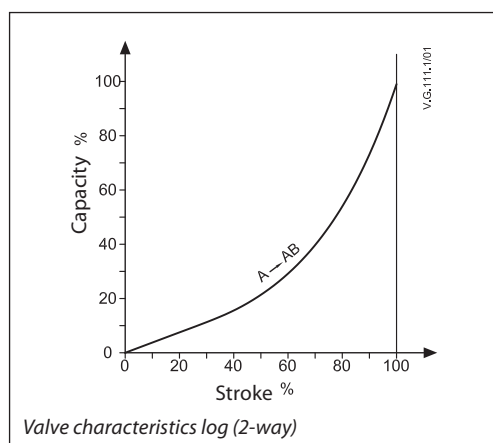

Installation

Hydraulic connections

Mount according to flow direction as indicated on valve body.

Leave sufficient clearance to facilitate the dismantling of the actuator from the valve body for maintenance purposes.

Valve mounting

Before mounting the valve be sure that the pipes are clean and free from swarf. It is essential that the pipes are lined up squarely with the valve at each connection and that they are free from vibrations. Install the motorized control valves with the actuator in a vertical or horizontal position.

Note that the actuator may be rotated up to 360° with respect to the valve body by loosening the retaining fixture.

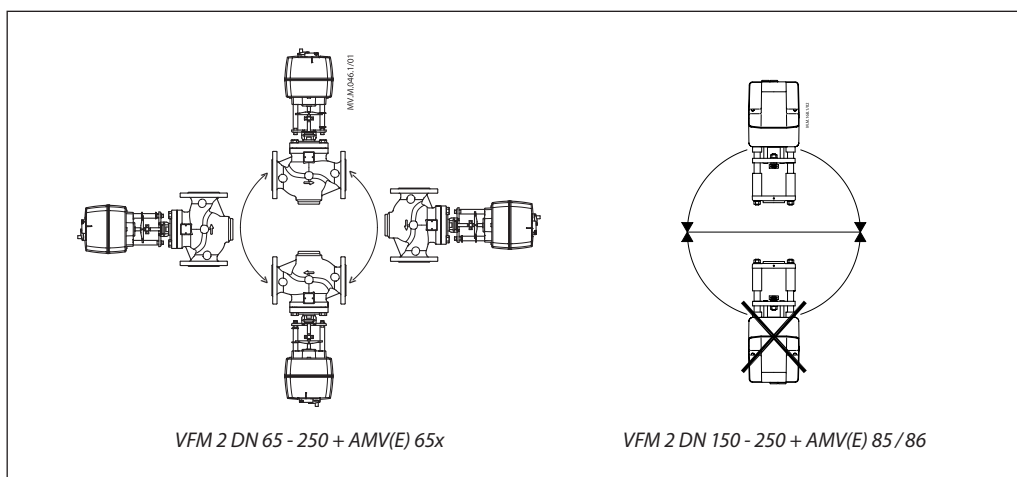

Disposal

The valve must be dismantled and the elements sorted into various material groups before disposal.

Design

- 1. Valve body
- 2. Valve cover
- 3. Stuffing box
- 4. Valve stem
- 5. Valve cone (pressure relieved)
- 6. Valve seat

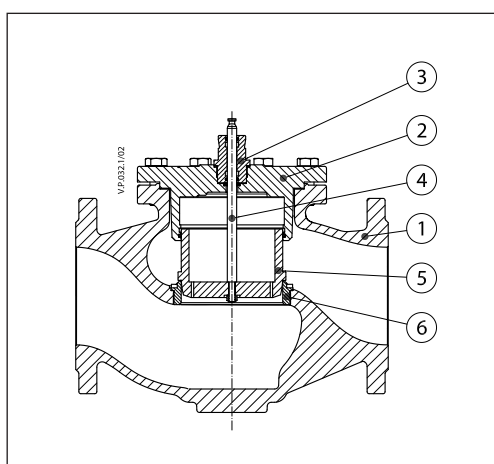

Sizing

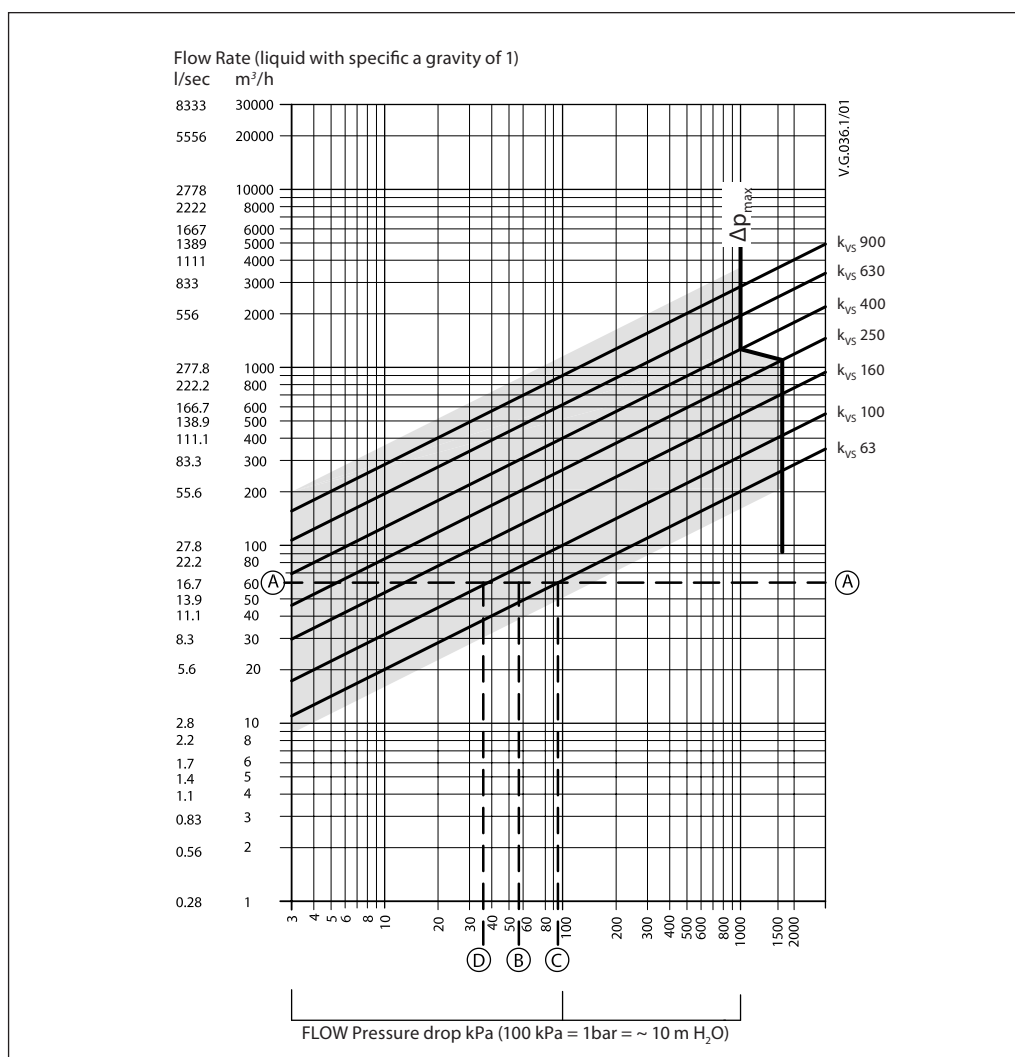

Example

Design data:
 Flow rate: 60 m³/h
 System pressure drop: 55 kPa

Locate the horizontal line representing a flow rate of 60 m³/h (line A-A). The valve authority is given by the equation:

$$\text{Valve authority, } a = \frac{\Delta p_1}{\Delta p_1 + \Delta p_2}$$

Where:
 Δp₁ = pressure drop across the fully open valve
 Δp₂ = pressure drop across the rest of the circuit with a full open valve

The ideal valve would give a pressure drop equal to the system pressure drop (i.e. an authority of 0,5)

if: Δp₁ = Δp₂

$$a = \frac{\Delta p_1}{2 \times \Delta p_1} = 0,5$$

In this example an authority of 0,5 would be given by a valve having a pressure drop of 55 kPa at that flow rate (point B). The intersection of line A-A with a vertical line drawn from B lies between two diagonal lines; this means that no ideally-sized valve is available.

The intersection of line A-A with the diagonal lines gives the pressure drops stated by real, rather than ideal, valves. In this case, a valve with k_{vs} 63 would give a pressure drop of 90,7 kPa (point C):

$$\text{hence valve authority} = \frac{90,7}{90,7 + 55} = 0,62$$

The second largest valve, with k_{vs} 100, would give a pressure drop of 36 kPa (point D):

$$\text{hence valve authority} = \frac{36}{36 + 55} = 0,395$$

Dimensions

