



# Installation Guide for Underfloor Heating Systems

TECHNICAL INFORMATION - JULY 2013



	12mm PEX	16mm PEX	20mm PEX	16mm MLCP
TM manifold	✓	✓	✓	✓
LS manifold	✓	✓	✓	✓
Solid Screed Floor		✓	✓	✓
Timber Suspended Floor		✓	✓	✓
Floating Floor System	✓	✓	✓	✓
Tracked Plywood Panel System	✓			
PUSH 12	✓	✓	✓	✓
Compact Control Pack v5	✓	✓	✓	✓
VPG 10	✓	✓	✓	✓
PPG 20	✓	✓	✓	✓
PPG 30	✓	✓	✓	✓
Climate Controller	✓	✓	✓	✓

## Technical Support - 24/7 answers

Specially designed mobile helpsite

**www.uponoruk.mobi**

is a way you can access technical answers to your Underfloor Heating and Plumbing queries



Generate a code online in minutes... [www.one-pack.co.uk](http://www.one-pack.co.uk)



## Professional underfloor heating!

An easy to order and install pack for solid screed floors up to 75m<sup>2</sup>

**AUTOBALANCE**  
TECHNOLOGY

with every single pack!

Up to **12%**  
Energy Saving!

- No manual balancing
- Improved heat distribution
- Accurate, quicker control
- Up to 25% quicker reaction time
- Easy to operate



# Contents

Introduction and Guarantee .....	4
Underfloor Heating Design Principles .....	5
Preparation and Installation Principles .....	9
(prior to installation)	
<b>Installation instructions .....</b>	<b>13</b>
• Manifolds .....	14
• Solid Screed Floor .....	16
• Self Attaching System .....	19
• Timber Suspended Floor	
- Heat Emission Plates .....	24
- Unifoil Systems .....	25
• Floating Floor .....	27
• Tracked Plywood Panel System .....	30
<b>Water Temperature Control .....</b>	<b>35</b>
• Push 12 .....	36
• V5 Compact Control Pack .....	38
• VPG and PPG Control Sets .....	40
• Climate Controller .....	43
Uponor Heating & Cooling Controls .....	47
• Room Control user guides .....	53
Mechanical & Electrical Schematics plus typical layout .....	63
Heat Pumps .....	79
Filling, Venting and Pressure Testing .....	81
Starting-up & System Operation .....	85
• Auto-Balance .....	88
• Trouble Shooting .....	90
Tools & Accessories .....	93

## Introduction and Guarantee

Underfloor heating (UFH) systems are not difficult to design or to install, but it is important that the guidelines and instructions are carefully followed to ensure that the system performs correctly once installed and has a long service life.

This guide explains the fundamental principles and design of Uponor UFH and also gives installation guidelines for the components and systems.

Heating engineers familiar with installing conventional central heating systems will be accustomed to working with radiators, convectors and copper pipes.

Installing UFH is different, although the heat source is often the same, the materials and method of heat distribution are different.

1. There is a central distribution point, the manifold, which is served by the primary heating source and which distributes warm water to the pipes of the UFH system.
2. UFH operates with a low water temperature flow and return and therefore requires its own water temperature controls and own pump.
3. UFH uses the whole floor area as the heating medium, replacing radiators or convectors.

The use of Uponor pipe systems makes the installers physical task much easier. However, it is vital that the work is done correctly, as once the installation is complete and pipes are embedded in the floor, it would be difficult to make changes.

### Responsibility

The overall efficiency of the system is inherent in its design. The installer is solely responsible to the client for ensuring that the design and system criteria are followed. The system must be installed in accordance with the design and with other recommendations contained within this guide.



This guide is not intended to override the skills of the individual installer; it is published simply as a guide to installing Uponor Underfloor Heating Systems and is based on methods and practices developed over many years. It is hoped that it will provide a useful background on installation for those who are not yet familiar with the system.

Words and pictures obviously cannot replace experience. The guide should be read through BEFORE attempting the first installation. It is the responsibility of the client to ensure that all relevant information is supplied and to ensure that any design work from Uponor is suitable for the particular purpose.

Uponor trained installers are available to install the UFH system. Technical support is available from Uponor to help with queries, if others are installing the system. However, it is important to note that the ultimate responsibility for the system operation rests with the installing company.

**Uponor Limited has a policy of continuous improvement and reserves the right to change any specification without notice.**

### Guarantee

Uponor Limited ("Uponor") guarantees [to the original purchaser/customer] that pipes and fittings sold by it are free of defects in materials or manufacture under normal conditions of use for a period of 25 years and in case of electrical and mechanical products for 2 year from the date of installation. This guarantee only applies to the products stored, installed, tested and operated in accordance with the Fitting Instructions issued by Uponor and valid at the time the products were installed.

Where a claim is made during the guarantee period and products are proven to be defective in materials and/or manufacture at the time of delivery, Uponor will supply replacement products free of charge. This is the exclusive remedy under this guarantee.

Uponor disclaims any warranty or guarantee not expressly provided for herein, including any implied warranties of merchantability or fitness for a particular purpose.

Uponor further disclaims any and all responsibility or liability for losses, damages and expenses, including special, direct, indirect, incidental and consequential damages, whether foreseeable or not, including without limitation any loss of time or use or any inconvenience arising from the ownership, installation or use of the products sold hereunder.

This guarantee does not affect the statutory rights of the consumer.

# Underfloor Heating Design Principles

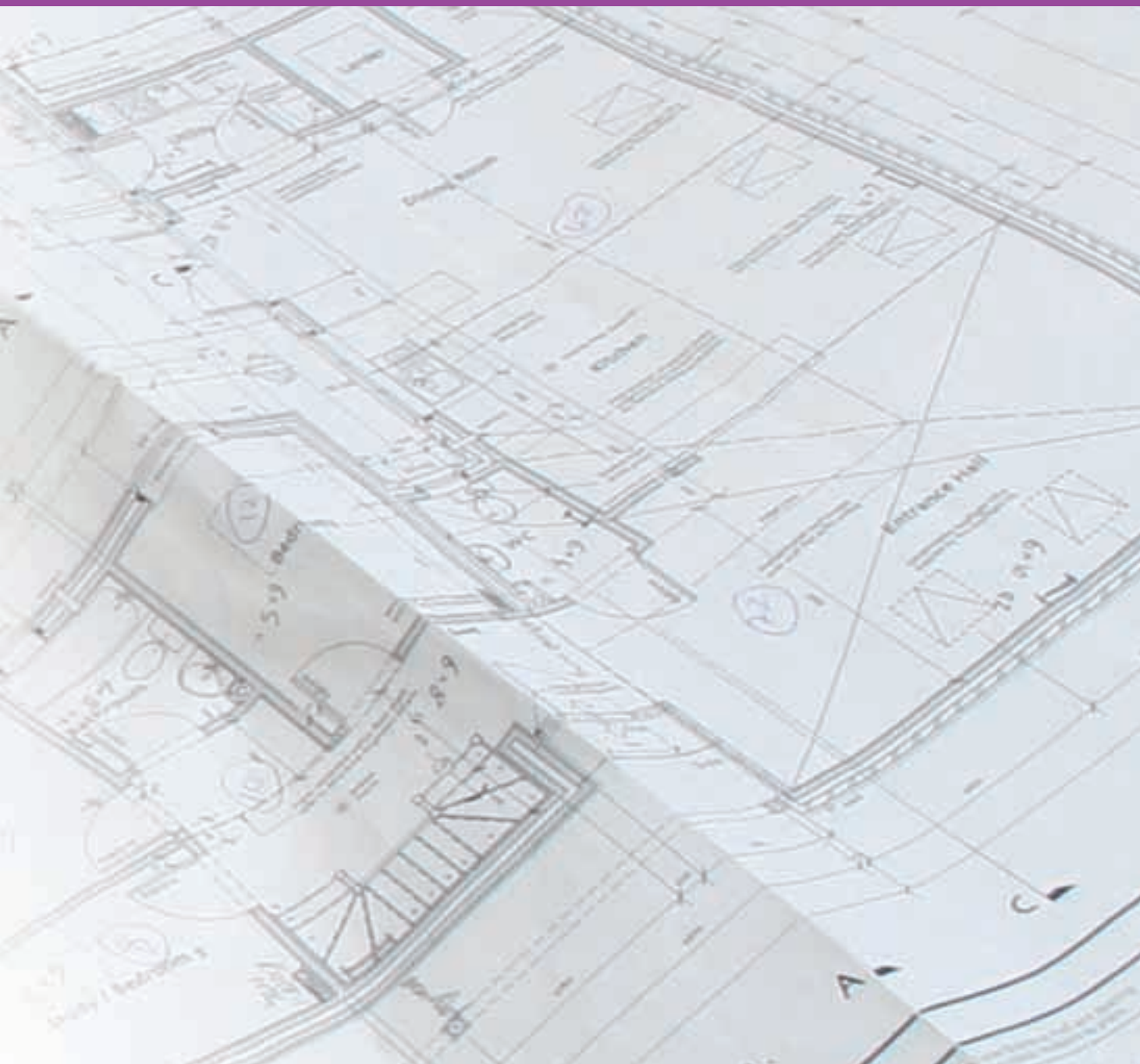

**This section provides information about how the underfloor heating (UFH) system is designed and highlights points to consider before the design work commences.**

- Points to consider \_\_\_\_\_ 06
- Floor construction type \_\_\_\_\_ 06
- Pipe spacing and layout \_\_\_\_\_ 07
- Insulation \_\_\_\_\_ 08
- Floor coverings \_\_\_\_\_ 08



## Underfloor Heating Design Principles

### Space Heating

Whatever the method used, the purpose of all space heating is to create an acceptable level of human comfort within a defined area. "Comfort" however, is a subjective concept. It will vary from person to person according to their age and activity level. There is therefore no universal ideal design temperature for all occasions - a sheltered housing project may require air temperatures of 21°C, while just 15°C may be adequate in a gymnasium or indoor sports hall.

### Principles

The principle of UFH is very simple. Rather than mount metal panels on walls, pipes are laid in the floor and warm water circulated so that the floor effectively becomes a large radiator. Because the floor is so large compared to a normal wall-mounted radiator, it needs to run only a few degrees above the air temperature to provide enough warmth to gently heat the whole room.

The primary aim of the floor heating design is to create an even, uniform surface temperature across the entire floor area within the building in order to ensure a consistent comfort level throughout the structure. When the floor temperature is higher than the air temperature, the floor will emit mainly radiant heat. The heat output from the floor is directly related to the temperature of the floor and that of the surrounding air.

Loops of pipes are normally installed beneath the whole floor area. These loops are connected to a central manifold, which is supplied with hot water from a suitable heat source - such as a boiler or heat pump - heat pumps are becoming ever more popular due to the potential energy savings. Usually, with boilers as the heat source, the central heating water is mixed before it reaches the manifold to reduce the water temperature to that suitable for the UFH system. Controls reduce the water temperature to maintain the correct design temperature and pump the warm water through the UFH pipes.

### Heating with UFH

UFH is a true radiant system and heats from floor to ceiling. UFH avoids wasted heat at high level and since the whole floor is heated evenly, optimum comfort is achieved everywhere in the room.

In fact, the room thermostat can be set 1 – 2°C lower than a radiator system and the room will still feel more comfortable! Running the system at a lower temperature and reducing the heat wasted at levels above head height makes for significant savings on fuel costs. The exact savings that can be expected are difficult to determine, as there are operational factors that also need to be considered.

### Heat Outputs

It is the clients responsibility to check that heat losses of the building, carried out by a heating consultant or engineer, are compatible with the outputs given.

Generally, the maximum output from an UFH system is often stated at between 70 and 100 W/m<sup>2</sup>. The actual output achieved is a direct relationship between the difference in floor surface and room air temperatures. The floor construction, floor covering material, pipe size, pipe spacing, and the temperature of water circulating through the UFH pipes are major factors that determine the floor surface temperature.

When designing conventional heating systems it is necessary to know the required heat output to be able to size the heat

emitter. However, for UFH the size of the emitter is fixed - it is the floor area. Hence, the heat output is a function of the operating temperature of the floor, the floor area, and room air temperature.

### Heat Requirements & Supplementary Heating

Given the low U-values stipulated in current Building Regulations, it is unusual to require outputs greater than 70W/m<sup>2</sup>, based on a 20°C internal design temperature. It is important to note that poorly insulated buildings, conservatories, areas with high ceilings and rooms with high internal temperature requirements, may require supplementary heating during mid-winter conditions.

The heating consultant or engineer should provide heat loss calculations. Heat losses are calculated in the conventional way and the boiler size will be similar whether UFH or other heating system is used.

Uponor will specify maximum heat outputs for the floor and air temperatures specified. Providing the project complies with current building regulations, particularly with regard to thermal insulation levels, these outputs should be more than adequate to meet heat losses and provide full comfort conditions.

### Design Limits

Establishing the correct operating temperature for the floor surface is a balance between not having the temperature so high that it causes discomfort, but high enough so that sufficient heat output is provided to meet the calculated heat losses. BS EN 1264-2:1997 states that the 'physiologically agreed' maximum floor surface temperature is 9°C above the room temperature. This results in a maximum floor surface temperature of 29°C in typically occupied areas with a room temperature of 20°C. A 9°C temperature difference will equate to a floor heat output of 100W/m<sup>2</sup>.

### Floor Construction Type

Floor construction is another key factor in the design. Screed floors, suspended wooden floors and floating floors all require individual consideration to ensure optimum performance and an even distribution of heat across the surface of the floor.

The screed or solid floor system relies on the conductivity of the screed or concrete to conduct the heat from the pipe surface to the underside of the floor finish. Because the screed is itself heated to conduct the heat it tends to store considerable amounts of heat and thus provides a slow response when both heating up and cooling down.

Timber floor systems rely on the conductivity of components fitted within the floor to conduct the heat from the pipe to the underside of the floor finish. In order to achieve good results the pipes must transfer their heat evenly to the floor surface. Inadequate heat dissipation and hot spots can cause unsightly shrinkage, particularly with natural wood boards. Because the mass of a timber floor structure is less than the mass of a screed floor, the system response of a timber floor system is usually much faster.

The floating floor system is predominantly suitable for sheet flooring or some stronger laminates. The grooved insulation is structural and laid on top of a prepared base. Additional insulation may be required to ensure compliance with Building Regulations and to minimize downward losses.

### Water Temperature Control

To meet the requirements of BS EN 1264, water temperature control must be provided. This ensures that maximum floor surface temperatures are not exceeded. The 'V5 Compact Control Pack', 'VPG 10' and the 'Climate Controller' are designed to mix and control the primary heat source flow water temperature with the UFH return water temperature, to a requirement suitable for the UFH system.

### Boiler/Heat Source

Traditionally, the primary heat source has been a boiler, producing low temperature hot water for the system. Modern high efficiency condensing boilers are ideal for UFH as the low water temperatures allow the boiler to work in condensing mode.

If the heat source is able to provide and maintain a constant or variable water temperature at the requirement for the UFH, it may not be necessary to have any further water temperature controls.

If there are no services, other than the UFH, being supplied by the boiler and water temperature controls are used, it may be necessary to have a heat sink, such as a towel rail, prior to the UFH mixing valve to prevent the boiler from cycling and cutting out on high limit.

However, ultimately, careful thought must be given when choosing your boiler, as not all units are compatible. Always check the specific application with the boiler manufacturer

More recently, other sources have become available which are ideal for UFH such as ground source or air source heat pumps.

### Calculating Size of UFH Pump

The smooth inner surface of MLC and PEX pipes reduces the pressure loss, optimising the pipe length that can be used. The temperature drop across the pipe loop and the maximum required heat emission determines the water flow rate required through the pump. The Uponor V5 Compact Control Pack and pre-assembled VPG and PPG's are supplied complete with a suitably sized UFH circulating pump.

### Pipe Spacing

In solid screed floors and areas of average to low heat loss, Uponor will generally recommend standard pipe spacings of 300mm (20mm diameter pipe) or 200mm (16mm diameter pipe). In areas of high heat loss, the pipe spacing may be reduced to a minimum of ½ the standard spacing to achieve higher heat output. Such areas include: highly glazed areas such as a conservatory, rooms with high ceilings, bathrooms with limited floor area and poorly insulated buildings.

Tighter pipe spacings can also be used within a peripheral zone, which is an area of floor between an external wall and 1 metre in from the external wall.

Pipe spacings may be reduced when renewable energy heat source, such as a ground or air source heat pump, is employed. In this instance, tighter pipe spacings will allow for lower hot water temperatures and result in improved efficiency and lower energy costs.

Ensure that there is sufficient pipe length available prior to installing at reduced pipe centres.

Timber suspended and floating floor pipe spacings tend to be fixed by the particular system and the UFH components used.

In order to calculate the amount of pipe required, the following guide can be used:

Pipe Spacing (mm)	Quantity of pipe (m/m <sup>2</sup> )
300	3.4
200	5.0
175	5.8
150	6.7
125	8.0
100	10.0

### Important Note:

**When calculating your pipe requirement, remember to add the feed/tail pipe lengths, between manifold and room, to your calculations.**

### Pipe Layout

Where possible, the pipe should be laid so that the flow direction is to the coldest area of the room first, e.g. under windows, along outside walls.

There are typically two patterns for installation in solid floors, the meander/serpentine pattern (1), or the bifilar/snail pattern (2). With the meander pattern the flow pipe is first directed towards the window or cold part of the room before returning backwards and forwards across the room at the defined spacing. The bifilar pattern is where the flow pipe is run at ever diminishing circles until it reaches the centre of the floor area, then it reverses direction and returns parallel to the flow pipe back to the starting point. Both patterns of installation are acceptable, however the meander pattern is often used against areas of high heat loss, while the bifilar pattern is employed where even floor surface temperature is required.

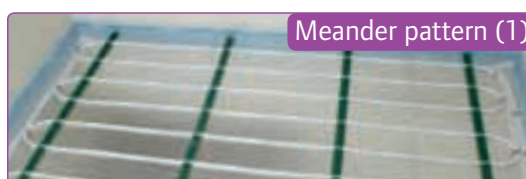

### Pipe Bend Radius

The minimum manual bend radius for Uponor pipe is:

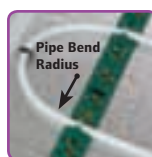

Pipe	min. Bend Radius
12mm PEX	60mm
16mm PEX	80mm
16mm MLCP	80mm
20mm PEX	100mm

On tight pipe spacing, allow the pipe to 'balloon' at the 180° turns.

## Underfloor Heating Design Principles

### Screed Floors

For solid floor construction, a normal sand/cement floor screed can be used. No special additives in the screed are required. Where the pipe is laid on insulation, the minimum screed depth must be 65mm for domestic applications and 75mm for commercial applications as specified in British Standards.

Uponor recommends that the optimum screed thickness is 75mm but no more than 90mm, for most applications. Where heavier floor loadings are required, the construction engineer should advise on the screed thickness.

Specialist Anhydrite (Calcium Sulphate) Screeds, when used with underfloor heating, must provide a minimum 30mm coverage over a pipe or conduit.

Careful consideration must be given to the expansion of heated screed floors. As a guide when using semi-dry cement and sand screeds, BS EN1264 - Part 4 recommends a maximum screed area of 40m<sup>2</sup> can be laid without expansion allowances. With Anhydrite screeds much greater areas can be laid without expansion joints; e.g. in Sports Halls up to 600m<sup>2</sup>. When using an Anhydrite screed always check with the supplier for their requirements.

The screed must be allowed to dry and cure normally, in accordance with the relevant BS Standards and manufacturer and supplier instructions, before initial heating and system start-up. The underfloor heating MUST NOT be used to speed up the curing process.

### Timber Floors

There are many types of wood flooring which are considered suitable for use with UFH and, equally, there are several methods of installing timber, which also must be taken into consideration before the system is designed. Particular attention must be paid to the moisture content of wooden floors. Not all timber floors are suitable for UFH and advice should be sought from the flooring supplier or from the trade association TRADA.

### Insulation

A layer of insulation should be applied beneath the circuit pipework to prevent downward heat loss, thus maximising the heat output into the room. It is also important to provide edge insulation around the perimeter of the area where UFH is installed, especially on screed floors, to avoid heat transfer/losses into the vertical structure. It also allows for an amount of expansion of the slab.

### Exposed Ground Floors:

Exposed ground floors should be thermally insulated to latest requirements of Building Regulations Part L (England & Wales) and in addition, for UFH systems, should limit downward heat losses to no more than 10W/m<sup>2</sup>. Supplementary insulation, above the normal Part L requirements, may be required if floor coverings with high thermal resistance are used. If insulation is already fitted below the concrete slab, a recommended minimum insulation thermal resistance of 1.25m<sup>2</sup>K/W should be installed above the slab (equivalent to Uponor 50mm Rolltec insulation boards), to improve the UFH system response times.

### Intermediate Floors:

Intermediate floors, with heated rooms below, should have a separating layer of insulation having a minimum 0.75m<sup>2</sup>K/W thermal resistance (equivalent to Uponor 30mm Self Attaching System Roll insulation), to comply with BS EN 1264-4. All floor constructions should be compliant with Building Regulations, including Part E and Part L (England & Wales).

It is the responsibility of the architect and/or the builder to ensure that the insulation is adequate for the requirements of the underfloor heating and Building Regulations.

**The relevant Building Standard codes for other countries are:**

**Northern Ireland - Technical Booklets F (Conservation of Fuel and Energy) and G (Sound).**

**Republic of Ireland - Parts L (Conservation of Fuel and Energy) and E (Sound)**

**Scotland - Sections 6 (Energy) & 5 (Sound).**

### Protective Layer

It is essential to prevent screed from slipping between the insulation board joints, creating a cold bridge and to inhibit the migration of water during the construction process. This is normally achieved by taping the joints of Uponor supplied insulation, such as, PUR board, Multifoil and Rolltec or alternative foil faced insulating boards, which have the protective layer incorporated within.

Alternatively if using an insulation without a protective layer, use a polythene film of at least 0.15mm thickness over the insulation, prior to laying the floor screed.

If using a liquid screed (calcium sulphate), please consult the screed specialist for confirmation of suitable layers to be used above the insulation.

### Floor Coverings

Most floor coverings can be laid on UFH systems. The floor covering supplier should be consulted to ensure that any special recommendations are followed, e.g. maximum temperature limits, wood drying conditions, special glues, etc.

It is strongly recommended that before any coverings are laid on screeded systems, the UFH system is run for two weeks (after normal screed drying time) and allowed to cool.

In all cases, it is recommended that thick felts, thick underlays, and cork are avoided. For optimum performance Uponor advise that a maximum combined thermal resistance, for floor coverings, of 0.15m<sup>2</sup>K/W is not exceeded, in accordance with the British Standard BS EN 1264, which equates to a carpet and underlay TOG value of 1.5. However, recent independent testing has shown that against current Building Regulations and reduced heat losses, a combined carpet and underlay TOG value of 2.5 is acceptable when used above a screed floor, although the underlay used should not exceed 1 TOG and must be suitable for use with UFH. We advise, where possible, to have masonry coverings, - e.g. ceramic floor tiles, slate, stone, marble etc - as this offers little thermal resistance and reduces downward heat losses. After the floor covering has been laid, the UFH system can be "tuned" to match the variations in floor coverings in each room by adjusting the manifold loop flowrates.



# Preparation and Installation Principles



Providing the installer with key elements to check prior to installation and ensuring the project runs smoothly.

- Before installing \_\_\_\_\_ 10
- Connection to primary circuit \_\_\_\_\_ 10
- First time tips \_\_\_\_\_ 10
- Floor types and tools required \_\_\_\_\_ 11

## Preparation and Installation Principles

### Before Installing

Prior to installation, it is important that the installer makes the following checks to ensure the project runs as smoothly as possible:

1. All the materials and the quantities are correct and on site against the delivery note and against the material schedule.
2. All other trades involved in the installation are fully conversant with component layout and positioning. For example, for first fix wiring, the electrician should know the positions of the room thermostats, water temperature controls, time clocks, etc (see Chapter 6 for further details).
3. Sub-floors are clean, level and are correct for the depth of construction needed to incorporate the underfloor heating.
4. Ensure all other trades not involved with the installation are notified and excluded from the installation area before and during installation.

It is important to read in full and understand all installation instructions offered before commencing installation.

### First Time Tips

- For first time installers, laying the pipe needs two people; one person holding the pipe coil and un-rolling it, with the second person, a couple of metres behind, securing the pipe in position. For ease of clipping pipe into insulation we would advise investing in a Kombi tacker gun (1002295).
- Only one person is needed if using a pipe de-coiler. Place the de-coiler in another room and pull the pipe off as required. (PEX only)
- Check which water temperature controls are to be used and where they are to be positioned to ensure that enough room is allowed for the manifold.
- Check the position of the manifold and fit the manifold before laying the pipe work.
- Ensure that the pipe does not become twisted when handling as it can become awkward to install. The pipe will twist slightly on bends but the print line is a good guide to assist in laying the pipe.
- During cold conditions, installation and handling will be easier if the pipes are stored overnight in a heated room before installing.
- To avoid kinks always pull the pipe to shape rather than bend and try and force into position.
- If the pipe does become kinked, the kink can be removed using one of these two methods, depending on which system is being installed:
  1. If using MLC pipe, gently squeeze the kink/crease with soft pliers and reform the bend away from the kink.
  2. If using PEX pipe, gently heat the kink/crease with a warm air gun (NEVER a naked flame) until the pipe is hand warm, max 130°C.

Contact Uponor for further technical advice if necessary.

- Always cut the pipe square and use a plastic pipe cutter ensuring that there are no burrs on the pipe ends. It is important to achieve a clean cut at right angles to the pipe.
- For solid floor, allow a minimum distance between pipe and wall face of 100mm.

### Connection to Primary Circuit

Each manifold and/or water temperature control station must be served by a flow and return from the central heating source and primary heating circuit. Where the heat source is providing water at the correct temperature for the UFH system, the manifold can be connected directly onto the primary pipework.

When using either the V5 Compact Control Pack or the pre-assembled VPG or PPG water temperature controller and a single manifold, connections can be made directly onto the manifold. Alternatively, when using the pre-assembled VPG/PPG controller or un-assembled mixing valve arrangement, located away from the manifold position, a mixed flow and return supply is required between the manifolds and controls, sized in accordance with the required flow rate and pressure drop.

Unless otherwise specified or requested, Uponor does not design or supply the primary supply pipe work.

As a precaution, Uponor recommends that a by-pass be fitted in the primary pipework.

## Floor types and tools required

Floor	Screed	Timber Suspended - Heat Emission Plates	Timber Suspended - Unifoil	Floating	Tracked Plywood
12mm PEX				✓	✓
16mm PEX	✓	✓	✓	✓	
16mm MLCP	✓	✓	✓	✓	
20mm PEX	✓	✓		✓	
<b>Tools required</b>					
Uponor plastic pipe cutter	Yes	Yes	Yes	Yes	Yes
Drill and necessary drill bits	Yes	Yes	Yes	Yes	Yes
Suitable wall fixings (for manifold)	Yes	Yes	Yes	Yes	Yes
Plumbers wrench/grips	Yes	Yes	Yes	Yes	Yes
Kombi Tacker Gun	recommended when using Kombi Klips				
Hammer			Yes	Yes	Yes
Sharp wood saw		Yes	Yes		
Chisel			Yes	Yes	Yes
Hacksaw			Yes		
Stanley knife		Yes			
Staple gun or tacks		Yes			
25mm pan head nails			Yes		
Insertion depth tool (for MLC pipe only)	Yes	Yes	Yes	Yes	
5mm Allen key (for LS manifold only)	Yes	Yes	Yes	Yes	Yes
Uponor polysterene hot cutter				recommended	
Table, mitre or circular saw and carbide blade					Yes
Commercial vacuum cleaner					Yes
Chalk line					Yes
Rubber mallet					Yes
Square					Yes
Tape measure	Yes	Yes	Yes	Yes	Yes

## UFH Installer Course

A two-day course at our purpose built facility in Lutterworth. The course is aimed at both new and experienced users of our products.

**Day 1** gives a thorough understanding of applications of UFH in our theory suite.

**Day 2** follows with practical exercises in our hands-on practical suite.



The Uponor Training Academy was established to offer you a range of industry accepted courses. Starting with a comprehensive installer training course and moving through to design and control oriented workshops, encompassing techniques associated with Uponor Plumbing and Underfloor Heating products.

We are also able to offer bespoke workshops, tailored to suit your individual needs. Our main training academy is a purpose built facility close to Junction 20 off the M1, in the market town of Lutterworth.



**Training Academy: 01455 551363**

**Uponor Head Office: 01455 550355**

**email: [training.uk@uponor.com](mailto:training.uk@uponor.com)**

**[www.uponor.co.uk](http://www.uponor.co.uk)**

**ALSO SEE PAGE 118  
FOR OTHER COURSES  
AVAILABLE**



# Installation Instructions



**This section will help you select the most appropriate system for your needs and take you through each stage of the installation.**

- **TM and LS manifold** \_\_\_\_\_ **14**
- **Floating floor system** \_\_\_\_\_ **27**
- **Solid screed floor** \_\_\_\_\_ **16**
- **Tracked plywood panel system** \_\_\_\_\_ **30**
- **Timber suspended floor** \_\_\_\_\_ **24**



## Installation Instructions - TM and LS manifold

TM & LS manifold	
12mm PEX	✓
16mm PEX	✓
20mm PEX	✓
16mm MLCP	✓

The Uponor Manifold is made from a high quality brass with a chromed finished and is for the distribution of hot and cold water in the area of radiant heating and cooling systems. The pipe loops are secured to these manifolds by the compression adaptors (supplied separately). Manifolds are supplied in pairs, i.e. a flow and return manifold, together with nickel plated fixing brackets. Manifold sets are available with between 2–12 outlets with a single loop extension set also available.

### Location

Manifold locations need to be positioned strategically and as central as possible, in order to reduce the amount and length of pipe tails and uncontrolled energy from pipes passing through heated areas en-route to other rooms/areas. It is important to select the manifold position at the beginning of the design process. If you have received a design and quotation from Uponor, manifold locations will be specified on the quotation.

Ensure there is sufficient height available, from the floor level to the lower return manifold, to enable easy connection of the UFH pipework (minimum 300mm). Although it is not necessary to have the manifold on show, it should be accessible for maintenance and servicing. Typical locations include; understairs cupboard, utility rooms, airing cupboards and cloaks cupboards.

### TM Flow Manifold

The supply section (top) offers shut off and flow rate control features, via the topmeter on individual loops. The topmeter is designed to provide the setting and visual indication (0-6 l/m) of each UFH loop flow rate, by adjustment of the meter. The red locking ring can be snapped over the topmeter to stop any unwanted changes made to the flow rate after commissioning has taken place.

### LS Flow Manifold

The supply section (top) offers shut off and flow rate control features, via the lockshield valve on each individual loop. A 5mm Allen Key is required to set each valve.

### Return Manifold

The return section (bottom) offers valves, including blue caps, for manual loop isolation. Caps can be replaced by electric thermal actuators for the provision of automatic room temperature control to individual loops. A suitable Uponor control system will be required to drive the thermal actuators.

### Fixing Brackets

Fixing brackets are supplied with the manifold. The brackets should be positioned on the wall and then the manifold secured in position. The lower manifold is staggered further out from the wall to allow the pipes from the upper manifold to pass behind.

If using the VPG or PPG control assembly directly onto the manifold, additional packers are supplied, which are required behind the manifold brackets.

If using a V5 Compact Control Pack, this can be assembled onto the manifold prior to fixing on the wall or alternatively the Control Pack can be purchased pre-assembled and fitted to the Uponor TM manifold.

### Fill & Drain Points

½" Fill & drain points are supplied with the manifold along with ½"FT x 1" MT couplers. Fit the couplers to the flow and return manifold headers and then screw the fill and drain points to the spare connections on the couplers.

### Connecting to the manifold

When laying the UFH loops, the first pipe end should be connected to the manifold before the loop is laid. Push the pipe-end lying on the outer side of the coil through and behind the return manifold and connect as per instructions below depending on which pipe is being installed. If insulating the feed pipes with Uponor conduit, we advise sliding this over the UFH pipe prior to connecting onto the manifold.

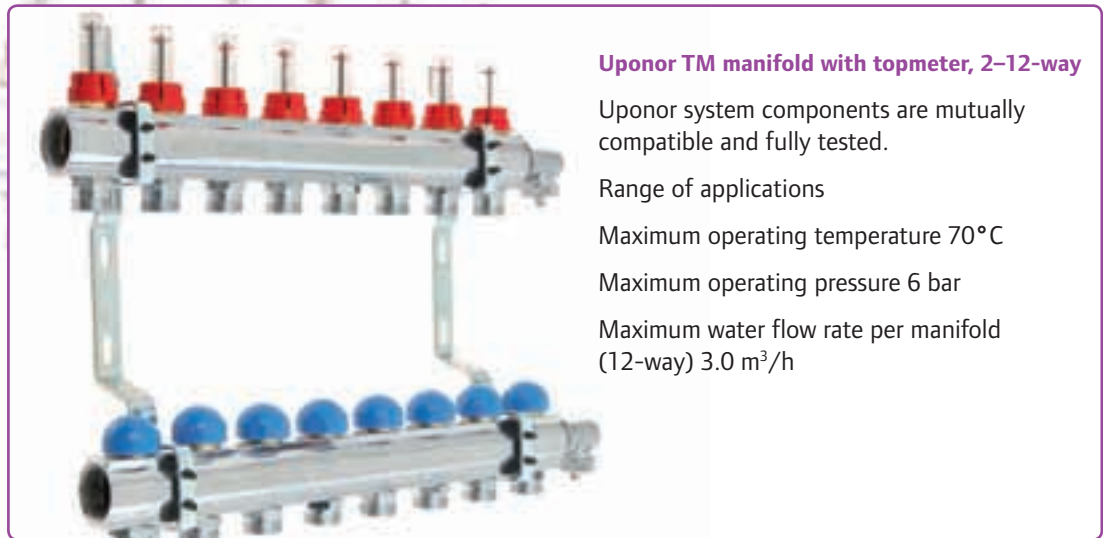

**Uponor TM manifold with topmeter, 2–12-way**

Uponor system components are mutually compatible and fully tested.

Range of applications

Maximum operating temperature 70°C

Maximum operating pressure 6 bar

Maximum water flow rate per manifold (12-way) 3.0 m<sup>3</sup>/h

### Connecting Uponor MLC Pipes

Before pushing the pipe behind the manifold, carefully bend the pipe to prevent it being damaged.

- 1 Line the pipe end up to the threaded port on the manifold.
- 2 Then cut the pipe end square using plastic pipe cutters.
- 3 Measure 10mm from the top of the pipe and mark the insertion depth.
- 4 Hand-tighten the compression adaptor fitting onto the

manifold outlet thread as shown.

- 5 Insert the pipe into the adaptor fitting and push until the pipe comes to a halt as shown (the insertion indicator should no longer be visible).
- 6 Now tighten the adaptor fitting onto the manifold, using an appropriate spanner, until the insertion depth mark can be seen again below the nut. (pic 7)

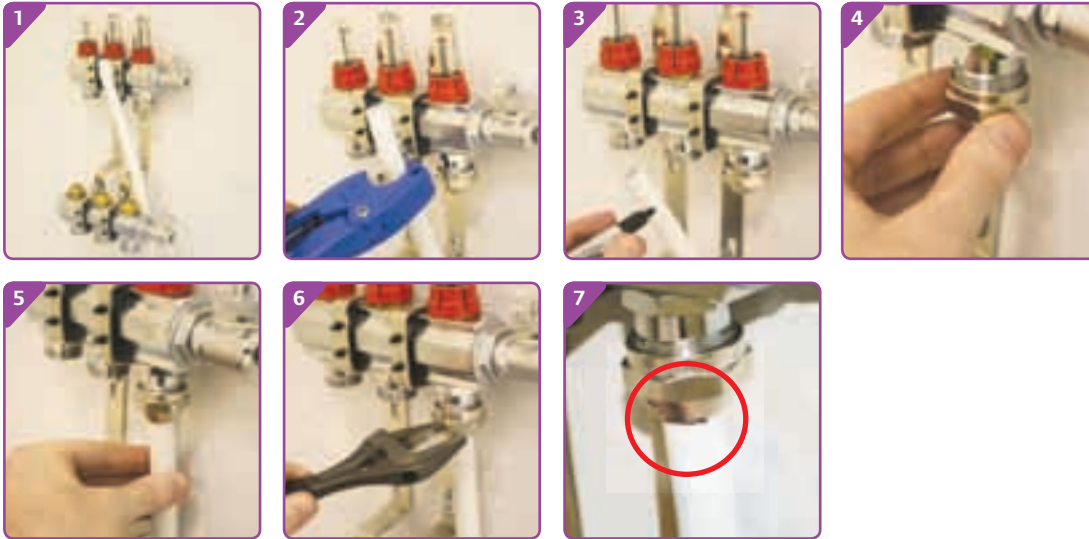

### Connecting Uponor PEX Pipes

- Ensure a pipe bend support is fitted where the pipe exits the floor and turns up to the manifold. Line the pipe end up with the threaded port on the manifold and cut the pipe end square using plastic pipe cutters.
- Push the nut and olive onto the end of the pipe. Then

push the insert fully into the pipe end in order to get a secure joint.

- Slide both the ring and nut onto the manifold port. Tighten the nut by hand.
- Then tighten a further one and half turns with a spanner.



### Loop connections

Make loop connections with 3/4" male-threaded Eurocone in accordance with DIN V 3838 compatible with Uponor MLC & PEX pipe adaptors.

### Observe the torque settings!

12 - 16mm: 50 Nm

20mm: 60 Nm

### Additional Items

- Automatic air vent with thermometer gauge (item no 1046886)
- Automatic manifold by-pass (item no 1048278)
- TM manifold one loop extension 1002197
- LS manifold one loop extension 1002181

**Note: The Uponor Manifold can be extended by one loop with the connection of an individual loop set.**

### Room Labels

Room labels are supplied with the manifold to identify the room being supplied, together with loop flow rate/settings.

### Loop control at the topmeter

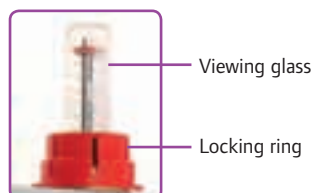

## Installation Instructions - Solid Screed Floor

Solid Screed Floor	
12mm PEX	
16mm PEX	✓
20mm PEX	✓
16mm MLCP	✓

When installing underfloor heating (UFH) within a solid screed, there are a number of different methods of fixing the UFH pipe into position, onto and above the floor grade insulation. The two most common methods are:-

### 1. Kombi Klip

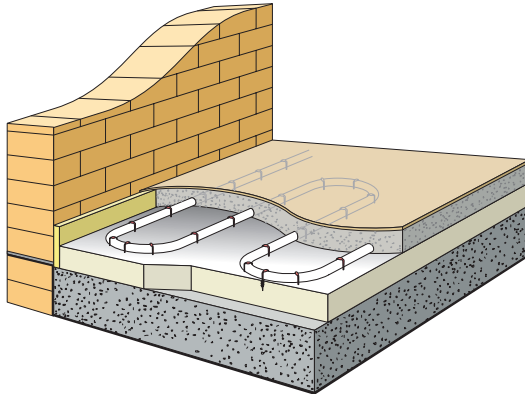

### 2. Clip Track and U-clip

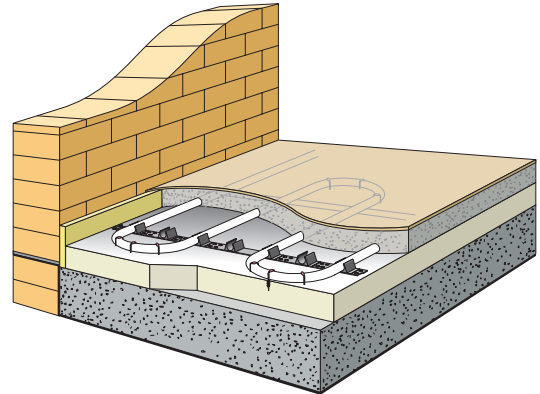

If using pipe-positioning plates, please use the installation instructions enclosed in each box to assist with the laying of the plates.

### Surface Preparation

The floor must be level and swept clean of dust and debris before laying the insulation.

### Pipe Bends

When laying the pipe, do not force the pipe into bends. It is easier to lay the pipe with a large radius and then gently pull the pipe to the required bend.

It is normal for the pipe to bulge out slightly like a 'light bulb'

on 180° turns, especially where pipe centres are closer than the standard pipe spacing.

Do not pull the pipe too tight or it may kink.

### Pipe Centres

When installing onto floor grade insulation, pipes should be spaced away, 100mm (16mm pipes) and 150mm (for 20mm pipe, from the wall edges. Thereafter, in modern well-insulated buildings the UFH pipe is generally installed at standard centres, 200mm (16mm pipes) and 300mm (for 20mm pipe) across the active floor area, unless otherwise specified.

## Installation

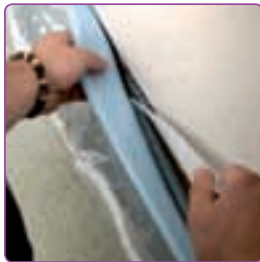

- Fix the edge insulation continuously around all internal and external wall edges, using the adhesive backing. When installed correctly the PE-skirt will be facing out from the wall and the embossed 'Uponor' will be legible.

Once the screed has dried and cured, the edge strip can be trimmed down.

- Lay the floor insulation over the entire floor area butting up to the edge strip, ensuring the PE skirt is overlapped and taped onto the floor insulation. If using Uponor insulation or another foil faced insulation board, tape the joints of all adjoining sections of insulation together to prevent screed slipping down between sheets of insulation and creating a cold bridge. Alternatively, lay a protective layer over the insulation.
- Fix the manifold into position, ensuring there is sufficient room to connect the water temperature controls and flow and return pipework.

- If using Clip Rail & U-clips, lay the rail across the floor to create a matrix for the UFH pipe. Use the self-adhesive backing to hold the rail onto the insulation. For meander pattern pipe installation, set the rail out on the insulation at a maximum 500mm spacing from two opposite wall edges and a maximum 2000mm spacing between clip rails. Ensure the clip rail is at a 90° angle to the coldest external wall.

Alternatively, if you wish to lay the pipe in a bifilar pattern, lay the clip rail over the insulation in a cross/star pattern with each clip rail strip converging in the centre of the floor area to be heated.

Once you are happy with the clip rail layout in relation to your proposed pipe configuration and routes, fix the rail permanently to the insulation by pushing the 'U'-clips through the holes provided in the clip rail at the leading and trailing end of the rail. If the length of rail exceeds 1m use additional U-clips at 500mm intervals.

On the actual pipe bends you may wish to use the U-clips directly over the pipe and into the insulation for extra hold. Insert u-clips at a 45° angle to gain maximum hold.

If the floor grade insulation is already installed below the floor slab and the additional insulation laid over the concrete slab is not sufficient to fix Uponor U-clips, we would advise fixing the rail directly to the sub concrete floor using suitable floor fixings (screws and plugs).

If using the Kombi Klips to fasten the pipe to the floor grade insulation, clip the pipe at 500mm intervals. More clips may be necessary on the pipe bends. Minimum 35mm insulation depth is required for the Kombi long and 25mm for the short. To assist with fixing the Kombi clips into the insulation we would advise using the Kombi Tacker Gun (Item no. 1002295)

### Clip Track Fixing



### Kombi Klip Fixing

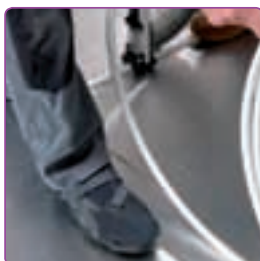

### Laying the UFH Pipe

In order to prevent the floor from overheating directly below the manifold or through doorways, where pipes are congested together, we would advise insulating the pipe, especially if they are not used to heat the room through which they pass.

- Identify each floor area to be covered by each coil/loop of UFH pipe. If you have had a design prepared by Uponor, the rooms to be heated and the coil lengths allocated to each area will be identified on your quotation and/or design layout drawing.
- When installing the pipe it is important to ensure the pipes do not cross over each other, therefore time should be spent, before actually laying any pipe, configuring the route for the feed pipes from the manifold location to their respective area/room to be heated.
- Typically, feed pipes pass through door openings, etc. However, where possible, particularly to areas adjoining the manifold location, feed pipes could be taken directly through partition walls and into their respective rooms. This will also help alleviate any congestion around the manifold location. Ensure all holes drilled are below the screed floor finished level. Also, when threading the pipe through the hole ensure it has been capped off and there are no

sharp edges, which could score and damage the pipe. It is recommended that the UFH pipes, when passing through walls, are sleeved with Uponor protective conduit.

- Once you have a clear picture of the installation, you can begin to install and lay the pipe. Firstly thread the first coil end behind the return manifold and connect onto the manifold flow port. If passing through a partition wall first thread the pipe through the hole and up behind the return manifold.

If using PEX pipe, 'pipe bend supports' must be fitted on every loop at the point where the pipes rise from the floor/insulation and up to connect to the manifold, i.e. 2 required per loop.

In all cases, the pipe should be laid so that the flow direction is to the coldest area of the room first, for example, under windows and along external walls.

To assist with installation, Uponor pipe is marked at every metre length. It is good practice to make a note of the starting metre at the manifold and keep referencing how much pipe has been laid whilst installing over the intended floor area. This will help ensure you leave sufficient pipe to return to the manifold. Each loop should be installed without any joints in the floor.



## Installation Instructions - Solid Screed Floor

### Installing the Meander Pattern (1)

Once you have entered the room/area to be covered, first lay the flow pipe around the perimeter with a gap, 100mm (for 16mm pipes) and 150mm (for 20mm pipe), from the wall to the coldest area and then meander up and down across the floor area back towards the point of entry, following the same route back to the manifold, clipping the pipe as necessary depending on the chosen method of fixing. On returning back to the manifold connect the tail end of the pipe to the corresponding return port on the manifold.



### Installing the Bifilar Pattern (2)

Once you have entered the room/area to be covered, lay the pipe around the perimeter of the active floor area to be covered, maintaining a gap, 100mm (for 16mm pipes) and 150mm (for 20mm pipe), from the wall edge and clipping the

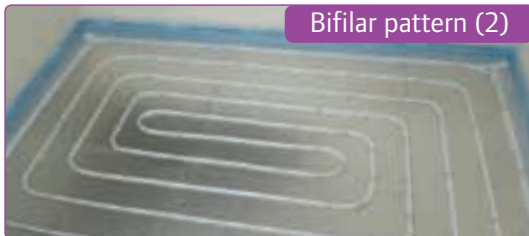

pipe as necessary. When you have circled the area and are back at your starting point, follow the same route around, but this time, at two times the design pipe spacing.

For example, if installing at 200mm centres across the floor area, follow the same route at 400mm centres. Continue spiralling this way until reaching the centre of the area. At this point turn back on yourself, making a hairpin turn and begin laying the pipe outwards centrally between the pipes already fixed on your inward journey, thus ensuring even 200mm pipe centres across the whole floor area and more importantly an even floor temperature. On returning back to the manifold connect the tail end pipe to the corresponding return port on the manifold.

### Screed Expansion Joints

Where pipes are to cross over a screed expansion joint, use a small section of conduit over the pipe, up to a minimum of 200mm either side of the joint.



### Inspection

Once the pipes have been laid, inspect the system to ensure all is as it should be.

Where used, snip back all sharp edges of mesh that may contact the pipe. Clip down any sections that have lifted to stop the pipe being too close to the finished surface.

### Pressure Testing

Once all the pipes have been laid and connected to the manifold, fill and pressure test the system.

### Sand-Cement Screed

Lay the screed as soon as possible to protect the pipes. At all times avoid unnecessary foot traffic.





## Optimal Productivity and Performance

### PROJECT SAVINGS

- **Remove work steps**

28db impact noise reduction can remove the need for installing a resilient acoustic layer

Built in membrane removes the need for installing a polythene layer above the roll insulation

- **Reduce overall build programme**

- **Save on cost of supplying and installing a resilient acoustic layer**

- **Halve the time of installing an UFH system or halve the installation cost**

### ACOUSTIC & INSULATION QUALITIES

- **28db impact noise reduction**

Tested to DIN4109

Identical laboratory methods to

BSEN ISO 140-8:1998

- **Better than some of the leading acoustic underlay products**

- **Potential for significant savings on supply and installation costs**

- **Meets BSEN 1264 insulation requirements for floors with heated rooms below**



### PEX-a 16x1.8mm UFH PIPE

- **25 year manufacturing defect warranty**

- **Design life in excess of 50 years in accordance with DIN 16892**

- **Design pressure of 6 bar at 70°C**

- **Available in coil sizes up to 640m**

- **Oxygen diffusion barrier conforming to DIN 4726**

- **Manufactured to ISO 9001 & 14001**

- **3.3 billion metres of pipe sold since 1972**

- **Conforms to EN ISO 15875**



[enquiries.uk@uponor.com](mailto:enquiries.uk@uponor.com)

Contact us on 01455 550355

## Installation Instructions - Self Attaching System (Solid Screed)

The edging strip must be fitted before the Uponor self-attaching system insulation is laid.

**Laying the Uponor self-attaching- system insulation**  
The Uponor self-attaching-system insulation is to be preferably laid in continuous strips in the room's longitudinal direction. For easier distribution of the heating loops, the marking grid should match the parallel insulating strips. Remaining surfaces in recesses, door opening and strips remaining along the walls are to be subsequently filled in with the remaining insulation. Always place the "free-hand" cut sides of the boards against the edging strip to eliminate gaps in the insulation.

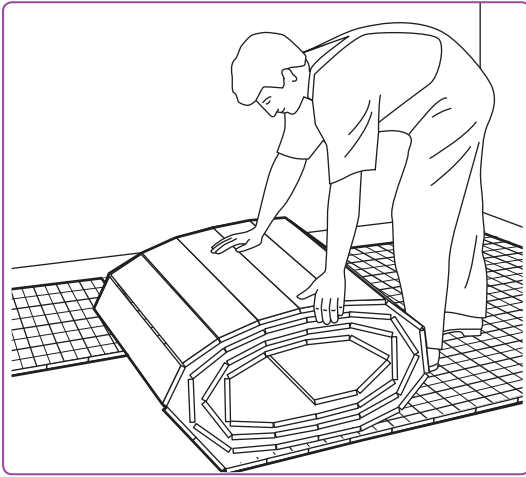

### Additional insulation

Additional heat insulation may be needed to comply with DIN EN 1264-4 and EnEV requirements.

### Masking the self-attaching system insulation joints

Masking all insulating strips joints (together with the bonded edging strip apron) creates a sealed trough ready to accept the heating screed. Precise masking stops any screed or screed water from penetrating the insulation as well as stopping acoustical bridges from being formed.

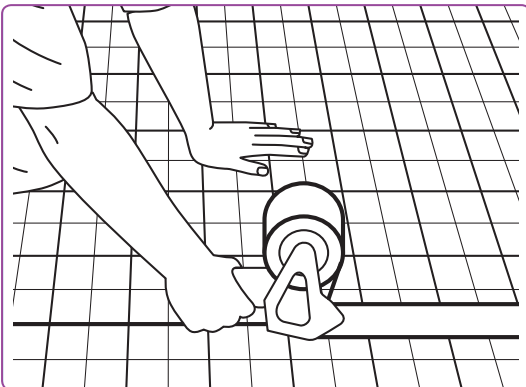

### Sealing the edging strip

To eliminate all gaps or cavities the edging strip foil apron must be bonded to the insulation boards. This keeps the foil from ripping and prevents the penetration of screed or screed water.

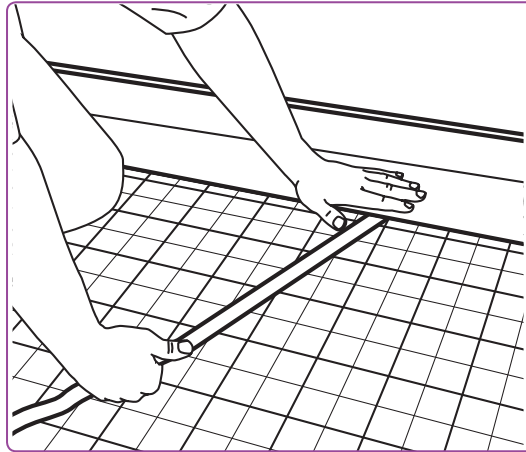

### Pipe laying

The heating pipes are laid on the boards at the predetermined distance without using tools. The microscopic hooks meshing with the looped sheets are sufficient to ensure that the pipes are fixed to the boards. No additional fixing is required. The minimum allowed bending radii of the pipes are to be maintained. All known methods of pipe laying are possible. It makes sense to mark the supply and return of the heating loops to ensure correct distributor connection. Uponor recommends installing pipes in the biffilar (snail) pattern.

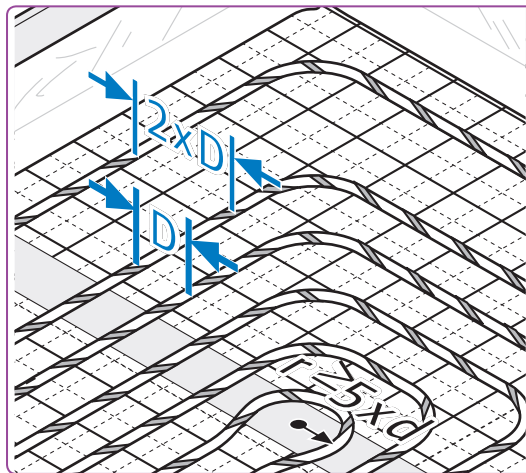

### Other notes

The radiant heating pipe is to be protected with Uponor protective sleeves in the area of the expansion joints. Before pouring the screed a pressure test is to be made in accordance with BS EN 1264-4. A test report is to be prepared.

The exposed parts of the edging strip may only be removed after completion of the flooring or when laying textiles and flexible coverings only after the hardening of the filler at the predetermined breaking points.

Before any floor covering is laid the screed must be heated up in accordance with BS EN 1264 part 4. For proprietary screeds please consult with the manufacturer for curing times and heat climatiation procedures.

Self-Attaching System	
12mm PEX	
16mm PEX	✓
20mm PEX	
16mm MLCP	

## Installation Instructions - Self-Attaching System

### Roll Insulation

The following pages are intended as a quick reference guide where you can see the main steps of installing self attaching system.

For more details please refer to the installation manuals that can be found inside the packaging of the products.

### Floor installation main steps

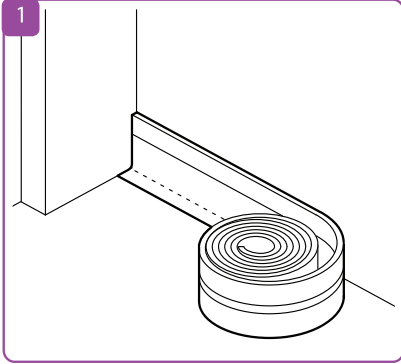

The edging strip should be installed prior to the insulation

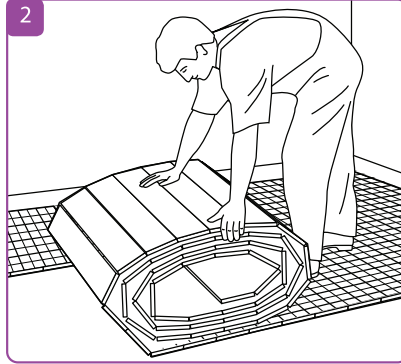

Lay the insulation roll length ways in the room and by matching the pre-printed grid

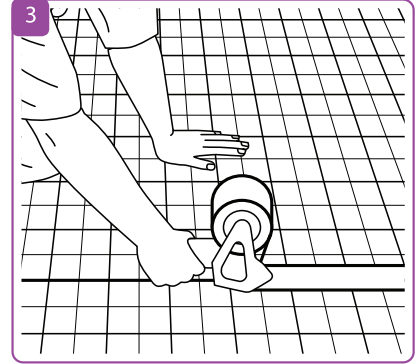

Seal the panels side by side using tape

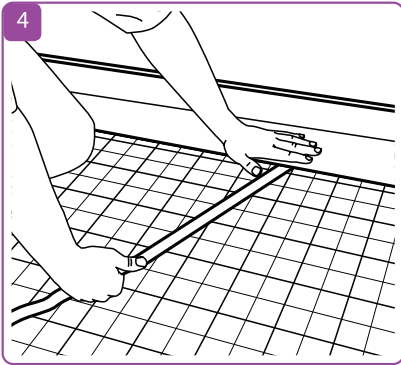

Seal the edging strip along the perimeter of the insulation

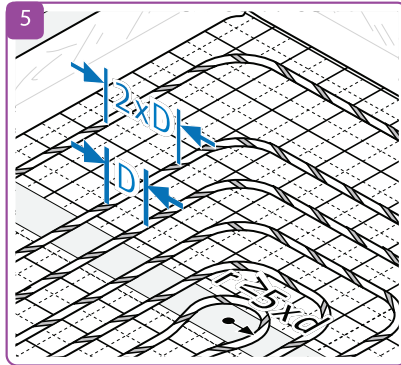

Lay the pipe by applying pressure with your foot to attach it to the insulation panel. Uponor recommends installing the pipe in a bifilar (snail) pattern. Bifilar pattern details shown on page 18.

### Pipe Leading Tool

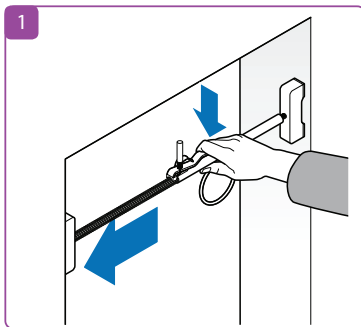

Position the pipe leading tool within the door frame, close to the top

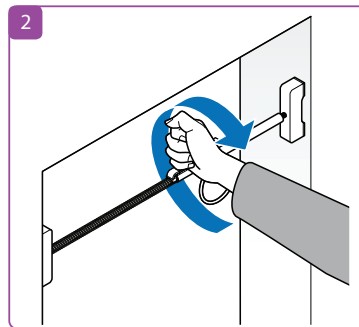

When you are happy with the position, and the ring is on the underside lock the tool in place

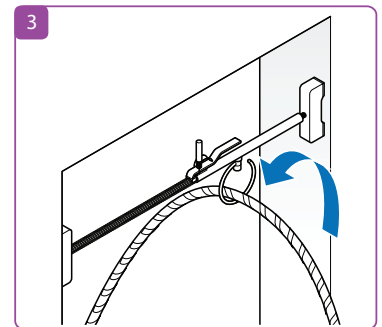

Insert the self attaching system pipe through the ring

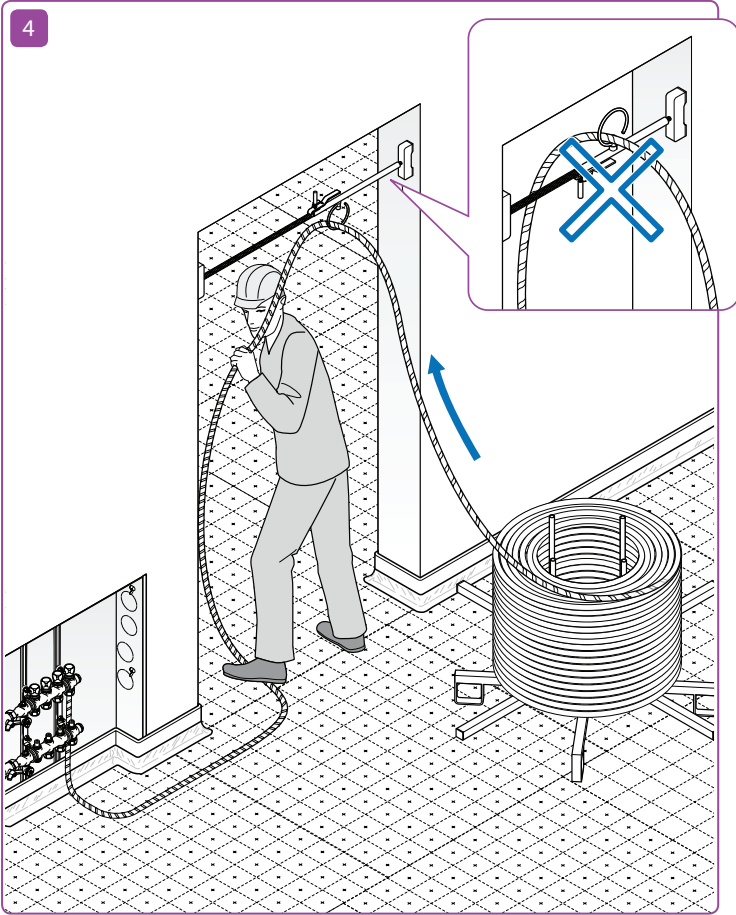

\*When connecting pipe to manifold use a 90° bend support for creating a stable bend.

Start laying the self attaching system pipe having previously positioned the de-coiler in an adjacent room

Pipe Leading Tool

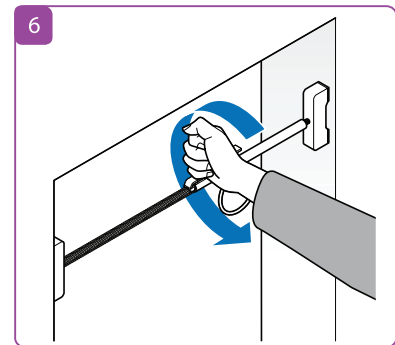
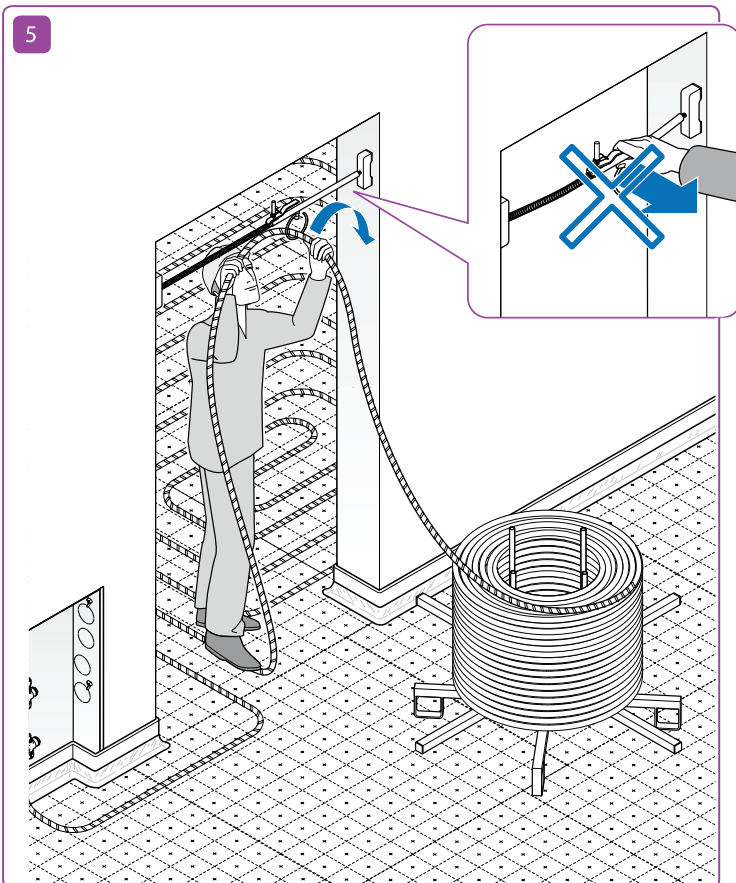

Remove the self attaching system pipe from the pipe leading tool but do not try to remove the tool itself

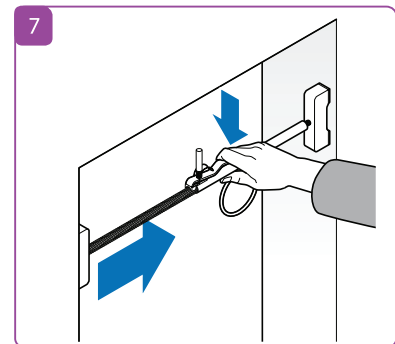

Unlock the pipe leading tool

## Installation Instructions - Self-Attaching System

### Compression Adapter

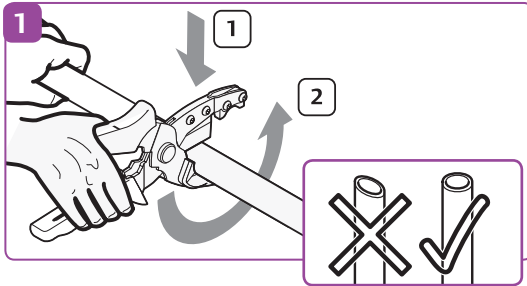

#### 1. Cutting to length

Cut the pipe to length at right angles with a pipe cutter. The edges must be straight and burr-free.

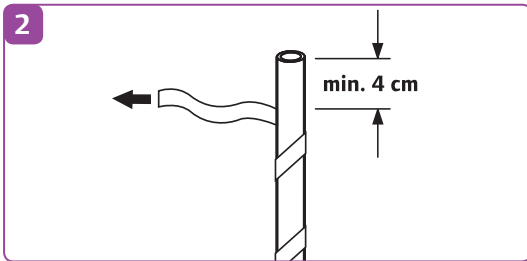

#### 2. Removing the self-attaching-system strip

Loosen and cut off at least 4 cm of the self-attaching system strip from the end of the pipe.

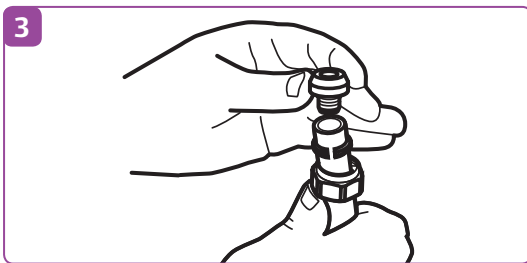

#### 3. Installation of the union nut and locking ring

First push the union nut and then the locking ring onto the end of pipe.

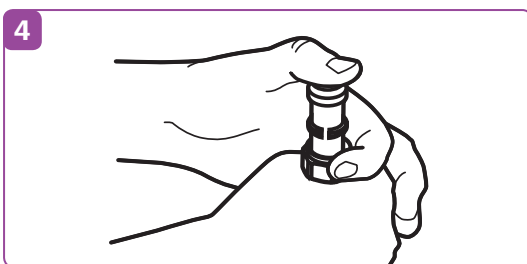

#### 4. Installation of the pipe inset (support sleeves)

Push the pipe inset (support sleeves) by hand into the pipe until the positive stop is reached. If manual force is not sufficient, it is possible to use a plastic hammer.

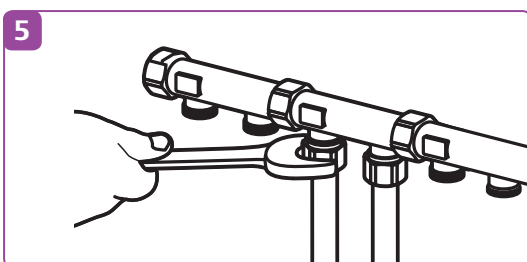

#### 5. Connection to the distributor

Attach the pipe to the distributor and secure the nut by hand. Then tighten the nut with a wrench until the torque noticeably increases.

#### Please note

With threaded locking ring connectors you must always use pipe inserts (support sleeves). If the compression adapter is loosened a new locking ring must be used. The reuse of a locking ring is not allowed.



## Installation Instructions - Timber Suspended Floor (Heat Emission Plates)

### Heat Emission Plates

Uponor have developed various heat emission plates (HEP's) to suit many timber floor applications. There are 4 plate sizes suitable for Uponor pipes, as follows:

#### HEP300

For use with timber suspended or battened floors with joists/ supports at 300mm centres. 20mm PEX pipe only.

#### HEP400

For use with timber suspended or battened floors with joists/ supports at 400mm centres.

#### HEP411

For use with sprung timber floors with battens spaced at 411mm centres, such as Junckers Unobat and Blubat Sports Floor Systems, suspended or battened floors with joists/ supports at 411mm centres. 20mm PEX pipe only.

### Insulation

It is essential that insulation is installed between the joists, as close to the underside of the plates as possible. Typically, a minimum 100mm of mineral wool insulation is used, however, where relevant, the insulation used must comply with current Part L and Part E (England & Wales) of the Building Regulations.

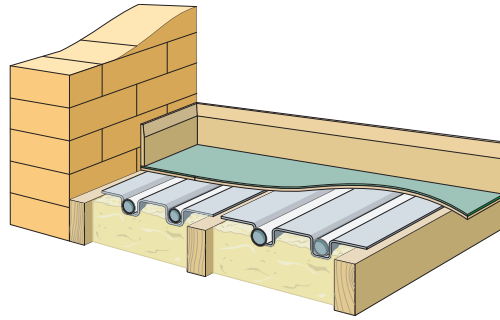

HEPs - Timber Suspended Floor	
12mm PEX	
16mm PEX	✓
20mm PEX	✓
16mm MLCP	✓

The relevant Building Standard codes for other countries are as follows:

**Northern Ireland - Technical Booklets F (Conservation of Fuel and Energy) and G (Sound).**

**Republic of Ireland - Parts L (Conservation of Fuel and Energy) and E (Sound)**

**Scotland - Sections 6 (Energy) & 5 (Sound).**

Item	Product code	Dimensions (m)	No. of pipe tracks	Plates/pack	*Pack Coverage (m <sup>2</sup> )
HEP400 (16mm)	1034365	0.38 x 1.15	Two	28	15.3
HEP300 (20mm)	1009132	0.28 x 1.15	Single	40	16.0
HEP400 (20mm)	1034492	0.38 x 1.15	Two	20	11.0
HEP411 (20mm)	1034491	0.405 x 1.15	Two	20	11.8

\*Equates to approximately 80% floor coverage

### Installation of Heat Emission Plates



- The plates are for heat distribution only and are not structural. They are easily damaged and it is very important that no other trades are allowed where the UFH is being installed. The heat emission plates normally cover approximately 80% of the floor area. Plates should never touch each other, as they expand when heated and can create noise. Plates are only laid under straight runs of pipe.
- Ensure all insulation and the necessary battening work is installed and complete, prior to laying of the plates. If cross battening, this is best achieved using 25mm x 100mm battens. Leave the ends of the battens loose so that the pipe loop can be laid beyond the end of or under the cross batten. Fix batten ends before laying floor.
- Lay the heat emission plates across the joists without fixing, leaving a gap between the ends and sides of each plate. Check to ensure appropriate number of plates are evenly spread out across the entire area before fixing.
- Lay the first plates at each end of the room, leaving a minimum 300mm space (16mm) and 450mm space (20mm) space from the wall edge, to enable the pipe to bend 180

degrees around. Thereafter space the plates out evenly ensuring gaps between plates are at least 10mm but less than 100mm. Use any sections of plates in the middle of the room.

- When the plates have been laid on the first row of joists, fix these into position and repeat the process for the remaining joists.
- Careful consideration should be given to the location of plates around the manifold area and along feed pipe routes, where the UFH pipes congregate together, cross joists at right angles and are non standard pipe centres.

### Cutting Plates

The plates are scored  $\frac{1}{3}$  from one end of the plate and at  $\frac{1}{6}$  from the other and are easily split along these score lines. Keep the pipe groove uppermost and sharply break the plate over a straight edge. If different lengths are required, score the plate deeply with a Stanley knife and cut along the pipe groove with a hacksaw.

Clean off the burrs in the pipe groove to prevent damage to the pipe.

## Installation Instructions - Timber Suspended Floor (Unifoil)

Unifoil - Timber Suspended Floor	
12mm PEX	
16mm PEX	✓
20mm PEX	
16mm MLCP	✓

### Unifoil

Unifoil is a multi-layer bubble film insulation with an aluminium coating bonded to its face. The aluminium is coated with polyethylene which gives a corrosion resistant fully waterproof insulation system.

Unifoil is a high performance material, tested by BSRIA (Building Services Research & Information Association) to prove its efficiency, which acts by trapping air within its structure, creating low emissive air spaces to enhance its total thermal capabilities. For use on intermediate timber suspended floors, with 50mm x minimum 160mm deep (for 20mm notching) joists at 400mm centres and chipboard T & G flooring/decking. The Unifoil system is not suitable for ground floor timber suspended floors with ventilated voids or rooms above unheated spaces below.

### Unifoil Technical Specification

- Thermal Resistance 1.45 m<sup>2</sup>K/W (inc air spaces)
- Fire Properties Foil face meets Class 1
- Environmental CFC & HCFC free
- Dimensions Thickness 4.5mm, Width 1.2m, Length 25m roll

### Coverage:

When used with standard 50mm joists at 400mm centres, one roll of Unifoil will cover approximately 20 square metres of floor area and will require 100 Unifoil clips.

### Additional Insulation

For optimum performance from the UFH system we would advise additional insulation is used below the Unifoil insulation,

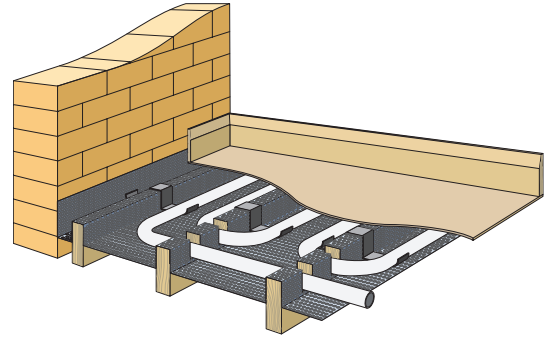

thus reducing the amount of downward heat loss. Typically, a minimum 50 - 100mm of mineral wool insulation is used, however, where relevant, the insulation used must comply with current Part L and Part E (England & Wales) of the Building Regulations or equivalent standards for Ireland and Scotland.

### Fire Properties

As only the foil face of the Unifoil meets class 1 fire approval, if installed directly over ceiling mounted light fixtures or other hot fixtures within the ceiling void, sufficient care should be taken to ensure the Unifoil does not become a fire hazard. Alternatively use another method of installation (see heat emission plates).

### Pipe Centres

The Unifoil clips are manufactured to saddle the floor joist and set the UFH pipe at 200mm centres, when used over joists at 400mm centres.

### Laying the Unifoil Insulation

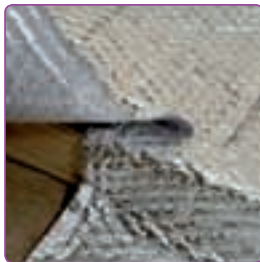

- First roll the Unifoil out over and at right angles to the joists with the foil facing upwards. We would advise not to pre-cut the insulation from the roll until you have secured each strip with the Unifoil clips.
- Unifoil must be brought up every wall edge by at least 75mm. The skirting board can be used to hide the foil edges.
- Unifoil is then fixed in place using Unifoil Clips, fixed at approximately 500mm centres, which saddle the foil over the joist. Once in place fasten the Unifoil Clip with a pan head nail through the hole provided. Leave at least 300mm gap from the wall edge and the first clip, leaving sufficient space for notching of the joists.
- On joists greater than 50mm wide, the clips can be cut in half and fixed either side of the joist. Alternatively, pipe clips can be used to fasten pipes to the sides of the joists.
- Work across the floor area to be heated, ensuring each strip of Unifoil overlaps the previous by a minimum 50mm.
- Please note the insulation roll is not structural and will not support a persons weight.
- The UFH pipe can now be laid.

## Installation Instructions - Unifoil

### Laying the Pipe for Heat Emission Plates & Unifoil



When laying the pipe, do not force the pipe into bends. It is easier to lay the pipe with a large radius and gently pull the pipe to the required bend before pressing into the next clip. It is normal for the pipe to bulge out slightly like a 'light bulb' on 180° turns.

Do not pull the pipe too tight or it may kink.

- Where possible, the design will ensure that the flow pipes are directed to the coldest part of the room. However, in suspended floors the pipe direction is dictated by the joist/batten direction.
- Identify each floor area to be covered by each coil/loop of UFH pipe (if you have received a design prepared by Uponor, the rooms to be heated and coils allocated can be identified on the quotation and/or design layout drawing).
- When installing the pipe it is important to ensure the pipes do not cross over each other, therefore time should be spent, before actually laying any pipe, configuring the route for the feed pipes from the manifold location to their respective area/room to be heated.
- Typically, feed pipes from the manifold pass through door openings. However, where possible, to avoid any congestion around the manifold and unnecessary notching, particularly to rooms adjoining the manifold location, feed pipes can be taken directly through partition walls and into the respective room. Ensure any holes drilled are below the floor level. When threading the pipe through the hole, ensure it has been capped off and there are no sharp edges, which could score and damage the pipe. It is recommended that the UFH pipes, when passing through walls, are sleeved with Uponor protective conduit.
- Mark out, notch or drill holes in the joists in compliance with current Building Regulations. When cutting the joist or batten, we would advise preparing a 20mm deep x 50mm wide (for 16mm pipes) or 25mm deep x 60mm wide (20mm pipe) notch, enabling two pipes to pass over the joist side by side. Where possible with Unifoil installation, lift the insulation foil to expose the bare timber before notching.
- Once you have a clear picture of the installation, you can begin to install and lay the pipe. Firstly thread the first coil end behind the return manifold and connect onto the flow port manifold. If passing through a partition wall, first thread the pipe through the hole and up behind the return manifold.
- If using PEX pipe, 'pipe bend supports' must be fitted on every loop at the point where the pipes rise from the floor to connect to the manifold, i.e. 2 required per loop.
- Lay the pipe, pressing it into the Unifoil clip by hand or, if using plates, gently by foot and meander the pipe up and down across the floor area towards the start position and manifold. Be careful not to bend the plates excessively, although it is normal for the plates to deflect a small amount.
- Do not pull the pipe tightly against notches to prevent additional stress on the pipe.
- To assist with installation, Uponor pipe is marked at every metre length. It is good practice to make a note of the starting metre at the manifold and keep referencing how much pipe has been laid whilst installing over the intended floor area. This will help ensure you leave sufficient pipe to return to the manifold. Each loop should be installed without any joints in the floor.
- Once the loop has been laid, take the pipe back to the manifold, following the same route out and connect the tail pipe to the corresponding return port on the manifold.

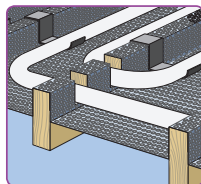

#### Inspection

Once the pipes have been laid, it is important to inspect the system before laying the floor, to ensure the installation is correct and pipes are held firmly away from any possible damage.

#### Pressure Testing

Once all the pipes have been laid and connected to the manifold, fill & pressure test the system.

#### Decking

The area should be decked out immediately after completing installation to protect the system. For safety reasons, foot traffic must be prevented until this is carried out. If necessary, the floor can be marked to show the pathway of the pipe runs and joists to assist the Floor Layer fixing down the floor.

#### Safety

It is the responsibility of the installer to ensure that the system is installed in accordance with all relevant Health and Safety Regulations and requirements.

## Installation Instructions - Floating Floor System

Floating Floor System	
12mm PEX	✓
16mm PEX	✓
20mm PEX	✓
16mm MLCP	✓

### Floating Floor System

The Floating Floor Panel can be laid on almost any existing floor surface. It is an ideal system for retrofitting UFH, or as an alternative to screeded floors.

### Floating Floor Panels

The pre-grooved insulation floor panel is made of polystyrene and designed for use with heat emission plates to distribute the heat over a wide area. When used on a ground floor installation, additional insulation may be required to ensure compliance with Building Regulations and to minimize downward losses ( $\leq 10W/m^2$ ).

### Surface Preparation

All subfloors should be clean, rigid and level prior to installing the underfloor heating system. Any projections must be levelled off as any imperfections in the slab will be projected through to the finished floor. The recommended maximum

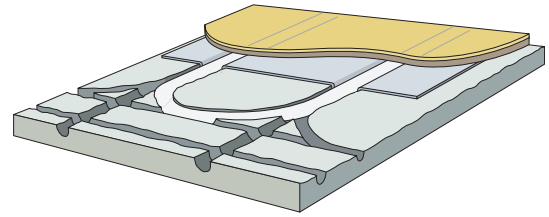

surface irregularity under a 3m long straight edge is 3mm in all directions. If a liquid based DPM has been used or self-levelling compound, it must be allowed to dry completely before laying any insulation. Where moisture control barriers are required these should be installed prior to laying the floating floor panels. It is a prudent precaution to install a moisture control barrier on all existing solid floors where the condition of the existing moisture barrier buried within the existing floor construction is unknown.

### Dimensional Details for 20mm PEX pipe

20mm PEX pipe	Panel thickness (mm)	Length x width (m)	Pipe spacing (mm)
Panels for 20mm pipes	30	1.2 x 0.79	300
	50	1.2 x 0.79	
Single heat emission plate	-	1.15 x 0.28	

### Dimensional Details for 16mm PEX and 16mm MLC pipes

16mm PEX & 16mm MLC	Panel thickness (mm)	Length x width (m)	Pipe spacing (mm)
Panel for 16mm pipes	50	1.2 x 1.2	200
Double heat emission plate	-	1.15 x 0.38	

### Dimensional Details for 12mm PEX pipe

12mm PEX pipe	Panel thickness (mm)	Length x width (m)	Pipe spacing (mm)
Main panel c/w heat emission plate	15	1.2 x 0.75	125
Feed & return panel	15	1.2 x 0.75	62.5
Heat Emission Plate	0.3	1.18 x 0.11	-

### Laying the Panels

Take care with the panels as they may easily be damaged. Lay the pre-grooved insulation panels across the whole floor, symmetrically keeping the grooves running across the floor area. It is preferable to stagger the rows of panels in a brick pattern to avoid 4 corners of adjacent sheets lining up. Avoid using small pieces of panels, especially around the perimeter.

### Additional Notes for 12mm PEX Floating Floors:

Visualise the route the feed pipes will take from the manifold to the heated room/area. If the manifold has 3 or more loops, you need to incorporate Feed Panels into the installation, this will allow feeds to be run at c/c 62.5mm pipe centres. If used determine the location of the Feed Panels, prior to laying the main Floor Panels within each room/area. The main Floor Panels have both bends and feed grooves at the panel header. These can be revealed by breaking off a small section of each heat emission plate.

To maintain an even floor height, 15mm plywood or chipboard (supplied by others) should be installed where underfloor heating is omitted, i.e. under baths, showers, kitchen units, etc. Insulation panel off-cuts should be used as infill pieces at doorways, etc.

### Cutting the Panels or Extra Grooves

It will be necessary to cut the panels in places, particularly in doorways and near to the manifold where the feed pipes congregate at less than standard centres. Use either a sharp long bladed knife or hand saw to cut the insulation boards. Additional grooves can be made in the insulation using a 230 volt polystyrene hot wire cutter (product code: 1006290). To cut 20mm PEX a replacement head (product code: 1002072) will also be required. Alternatively use a sharp knife or router to cut the groove.



## Installation Instructions - Floating Floor System

### Floating floor system for 16mm pipes



### Floating Floor System 12

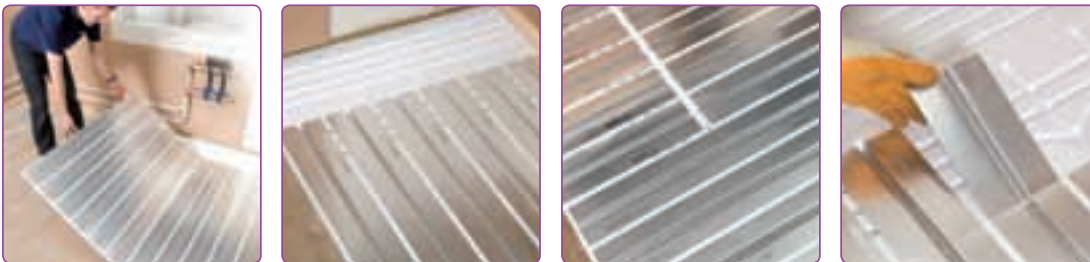

#### Laying the Heat Emission Plates

For 16 and 20mm pipes the number of plates allowed is given in the materials schedule. Plates normally cover approximately 80% of the floor area. Lay the heat emission plates in the required configuration, prior to pressing them into the grooves in the insulation panels. This ensures that the appropriate quantity of plates, is set out across the entire area. Where possible, configure the plate positions to run parallel with the coldest external wall and windows. Leave a gap between the ends of the plates; there will normally be a gap between the sides of the plates. Where extra grooves are cut into the insulation, the edges of the plates should be cut to avoid them overlapping.

- Start at each end of the room with full size plates, leaving a 300mm gap from the wall edge for bending the UFH pipe through 180 degrees.
- Fill in the middle with sections of plates.
- Space the plates out evenly ensuring gaps are at least 10mm but less than 100mm.

- When the room is evenly covered with plates press them into the grooves in the polystyrene.
- For 12mm PEX (System 12) Snap off' heat emission plates removed from the floor panels should be used on the pipe tails installed in the outer grooves of floor and feeder panels.

#### Cutting Plates

Apart from System 12 plates, plates are scored  $\frac{1}{3}$  from one end of the plate and at  $\frac{1}{3}$  from the other and are easily split along these score lines. Keep the pipe groove uppermost and sharply break the plate over a straight edge. If different lengths are required, score the plate deeply with a Stanley knife and cut along the pipe groove with a hacksaw.

Clean off the burrs in the pipe groove to prevent damage to the pipe.

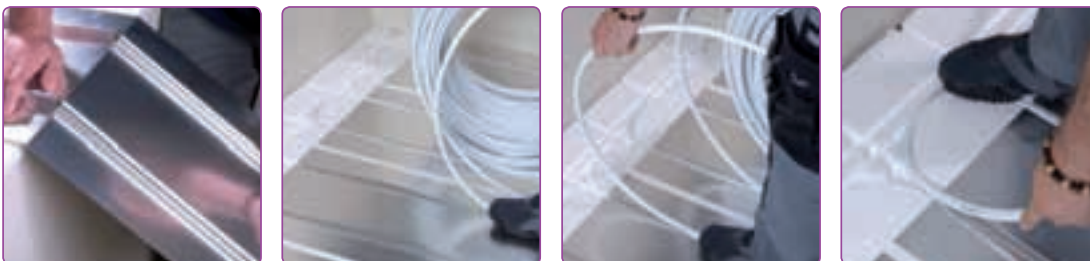

#### Pipe Bends

When laying the pipe, do not force the pipe into bends. It is easier to lay the pipe with a large radius and gently pull the pipe to the required bend before pressing into the next plate and insulation board.

Do not pull the pipe too tight or it may kink.

#### Pipe Centres

The plates and insulation boards are manufactured with grooves set at the following pipe centres;

12mm PEX	-	125mm
16mm PEX	-	200mm
16mm MLCP	-	200mm
20mm PEX	-	300mm

## Installation Instructions - Floating Floor System

### Laying the Pipe

- Where possible, the design will ensure that the flow pipes are directed to the coldest part of the room.
- Identify each floor area to be covered by each coil/loop of pipe (if you have received a design prepared by Uponor, the rooms to be heated and coils allocated can be identified on the quotation and/or layout drawings).
- When installing the pipe it is important to ensure the pipes do not cross over each other, therefore time should be spent, before actually laying any pipe, configuring the route for the feed pipes from the manifold location to their respective area/room to be heated.
- Typically feed pipes from the manifold go through door openings. However, where possible, to avoid any congestion around the manifold and through rooms adjoining the manifold location, feed pipes can be taken directly through partition walls and into the respective room. Ensure any holes drilled are below the floor level. When threading the pipe through the hole ensure it has been capped off and there are no sharp edges, which could score and damage the pipe. It is recommended that the UFH pipes, when passing through walls, are sleeved with Uponor protective conduit.
- Once you have a clear picture of the installation, you can begin to install and lay the pipe. First thread the first coil end behind the return manifold and connect onto the flow port manifold. If passing through a partition wall, first thread the pipe through the hole and up behind the return manifold.  
If using PEX pipe, 'pipe bend supports' must be fitted on every loop at the point where the pipe rises from the floor to connect to the manifold, i.e. 2 required per loop.
- Lay the pipe, pressing it into the plates grooves by hand or gently by foot. Where possible take the flow pipe to the coldest section of the room and meander the pipe up and down across the floor area towards the start position.
- It may be necessary to weigh down loop bends (do not use sharp objects), prior to laying the flooring and until the pipe has relaxed.
- Once the loop has been laid, take the pipe back to the manifold, following the same route out and connect the tail pipe to the corresponding return port on the manifold.

### Inspection

Once the pipes have been laid, it is important to inspect the system before laying the floor, to ensure the installation is correct and pipes are held firmly away from any possible damage.

### Pressure Testing

Once all the pipes have been laid and connected to the manifold, fill & pressure test the system as per Chapter 7.

### Decking

The area should be decked immediately to protect the system. Foot traffic must be prohibited until this is carried out to protect the pipe and the panels.

Laminate floor finishes should be a minimum of 7mm thick with inter-locking joints.

Chipboard or plywood floor deck should be a minimum of 15mm thick with glued tongue and grooved edges.

If required an intermediate layer between the underfloor heating and the finish floor can be installed to minimise the risk of movement/expansion noise; use lightweight flooring cardboard, heavy gauge paper, polythene sheet or finish floor supplier's/manufacture's solution to compensate for uneven and flexible subfloors.

As an alternative to laying tongue & groove chipboard flooring over the underfloor heating, 'Fermacell' or 'Knauf' dry flooring element (20mm or 25mm depth) can be used as it offers a lower resistance to heat transfer than chipboard and plywood.

The final floor deck should be installed as per the manufacturers/suppliers instructions.

## Installation Instructions - Tracked Plywood Panel System

A unique underfloor heating system incorporating plywood panels bonded, on the underside, to thin aluminium heat transfer plates. The panels have a central groove providing a tight fit for the 12mm pipes thus ensuring for intimate contact between pipe and heat transfer plate. The system comprises straight panel sections and other components to aid installation, such as the turn panel with U-shaped grooves to facilitate pipe turns between adjacent tracks.

With the relatively wide spacing of 175mm between pipe runs, means that only 6 linear metres of 12mm pipe is required per m<sup>2</sup> of floor area.

The system has been engineered for speed and ease of installation and can be fixed, or floated, on top of an even base. And to make things even better, Uponor have pre-assembled 6 tracked plywood panels together to enable 1.3m<sup>2</sup> to be installed in one go.

And best of all, the system has an ultra low profile of only 13mm making it ideal for integration into new builds and for retrofit floors.

Tracked Plywood Panel System	
12mm PEX	✓
16mm PEX	
20mm PEX	
16mm MLCF	

**A variety of floor coverings can be easily installed on top of the Uponor Tracked Panel system and some typical floor construction examples follow:**

### 1. Joisted floor with hardwood or laminate floor coverings.

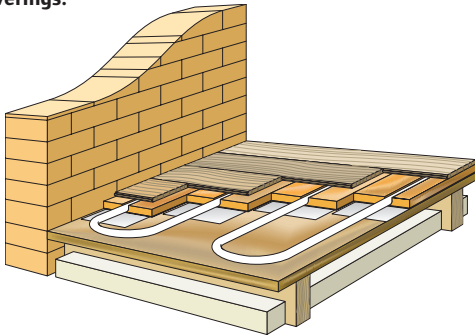

- Screw or staple Uponor Tracked Panels to the floor decking.
- Stagger the joints of the Uponor Tracked Panels.
- Hardwood or laminate floor should be installed in accordance with manufacturer's instructions. If using underlay, use 2mm polyethylene foam or similar material offering a low thermal resistance.
- Min. 100mm mineral wool insulation in joist void, or 150mm if installed over unheated areas or ground floor.

### 3. Joisted floor with carpet covering.

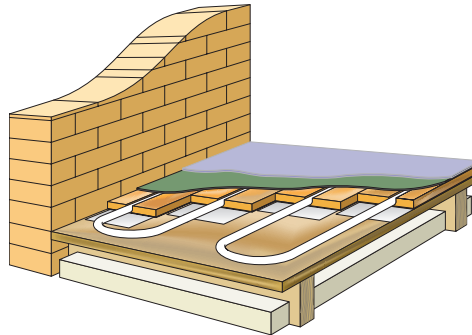

- Screw or staple Uponor Tracked Panels to the floor decking.
- Stagger the joints of the Uponor Tracked Panels.
- For minimum height build up, install underlay and carpet directly over the Uponor Tracked Panels.
- Underlay must have a TOG value of 1 or less and be suitable for underfloor heating applications. Do not exceed a combined TOG value of 2.5 for the underlay and carpet.

### 2. Joisted floor with tile, vinyl or linoleum floor coverings.

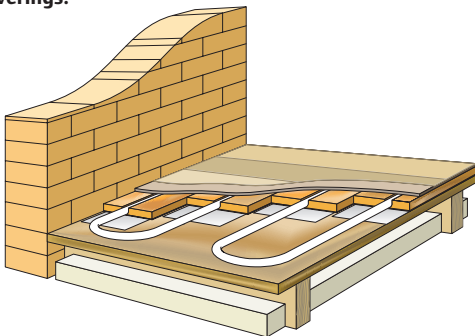

- Screw or staple Uponor Tracked Panels to the floor decking.
- Stagger the joints of the Uponor Tracked Panels.
- Glue and screw T&G or gypsum fibre boards to Uponor Tracked Panels.
- Use tiles suitable for thin bed fixing, or glue vinyl/linoleum to capping layer.
- Min. 100mm mineral wool insulation in joist void, or 150mm if installed over unheated areas or ground floor.

### 4. Concrete with insulation beneath the slab and floating floor finish.

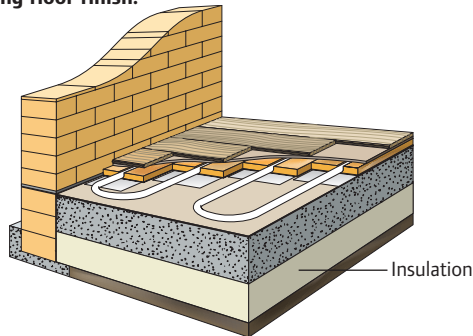

- Lay foam underlay over clean and level concrete slab.
- Insulation beneath the slab should be in accordance with Building Regulation requirements.
- Float pre-assembled Uponor Tracked Panels making sure to tape all joints.
- Install the floating floor system - if using plywood or chipboard, ensure that T&G boards are used and all joints are glued.

## Installation Instructions - Tracked Plywood Panel System

### Layout Planning

The layout of the tracked panels must be carefully planned before installation begins. The result of a well-planned layout will be minimal material wastage and a tidy installation.

First, determine where the manifold is to be located and then visualise the route the pipe feeds will take. The floor area close to the manifold will have tightly spaced pipes and, depending on the quantity of pipe loops, may be installed directly on top of the sub-floor decking. Later the spaces around the pipe can be filled in with off-cuts of plywood or by using a suitable levelling compound.

Alternatively, at manifold locations, 15mm MDF board or similar may be routed and used as a distribution board for the local pipe system. We recommend our timber panel system is installed and fixed prior to making the distribution panel.

### Panel Direction

Decide the direction that tracked panels will run.

### Tile floor finish:

Run the panels parallel to the outside wall with the greatest heat loss if possible. For joisted floors, running the tracked panels perpendicular to the floor joists will strengthen the floor, reduce deflection and give a more stable base for fixing the tiles. A capping layer over the timber panels is required for tile floor coverings. The capping layer should be suitable for floor finish and could be a 6mm plywood, gypsum/cement based board, or similar.

### Carpet or vinyl floor finish:

Run the panels parallel to the outside wall with the greatest heat loss if possible. For joisted floors, running the tracked panels perpendicular to the floor joists will strengthen the floor and reduce deflection. A capping layer over the timber panels is required for vinyl and linoleum floor coverings. The capping layer should be suitable for floor finish and could be a 6mm plywood, gypsum/cement based board, or similar.

For minimal build height when using a carpet finish, either a capping layer or underlay may be installed directly over the timber panel system. Underlays must have a maximum TOG value of 1 and be suitable for underfloor heating. Do not exceed a combined TOG value of 2.5 for the underlay and carpet.

### Hardwood or laminate flooring:

Always run the panels perpendicular to the hardwood/laminate flooring (regardless of joist direction). This will keep pipe visible during the fixing of the floor finish and reduce the risk of puncturing a pipe. Floating hardwood or laminate floor coverings should have tongue and groove inter-locking joints. If using an underlay, use 2mm thick polyethylene foam or similar material offering a low thermal resistance.

### Preliminary Layout

Once the direction of the tracked panels is determined, a layout must be designed. Mark any areas where panels are not required (e.g. beneath kitchen units).

From the wall, where standard 'Turn' panels are to be positioned, measure 180mm in (170mm for return panel width +10mm) and make a mark on the floor. Do the same at the other end of the wall.

Snap a chalk line between these two points to outline the location of the turn panels.

On the opposite wall mark a similar chalk line at 180mm in, if return panels are used – or at 310mm in (300mm +10mm), if the 'Feed & Turn' panel is used.

Determine the starting point for the first run of straight panels and snap a chalk line perpendicular to the other chalk lines using a square as a guide. The line must be at 90° to the Turn/Feed & Turn panels and not necessarily parallel to the wall.

### Panel Installation

- Use a circular, power mitre or table saw with a carbide blade for cutting the tracked plywood panels.
- Always follow the floor finish manufacturer's recommendation regarding installation. Where moisture control barriers are required these should be installed prior to laying the timber panels. It is a prudent precaution to install a moisture control barrier on all existing solid floors where the condition of the existing moisture barrier buried within the floor construction is unknown.
- Always install the tracked panels for one circuit at a time.
- Begin by laying the first row of panels parallel to the chalk line.
- To improve structural integrity, stagger the panels in each row so the joints are not lined up next to each other. Use the 6 pre-assembled straight panel units, which are already hinged together in a staggered format, for quicker installation.
- Fasten down one side of the panels by using a screw at each end. This allows for quick realignment, if necessary. Once all panels have been properly placed, screws should be used to fix both sides of the panels; 10 screws per panel to ensure that panels are securely fixed down. If the panels are to be floated over a solid floor base, instead of fixing the panels to the sub-floor, use strapping tape to fix the panels together. Alternatively, a layer of 18mm chipboard or similar can be installed and securely fixed to the concrete/screed base ready for installation of the system.

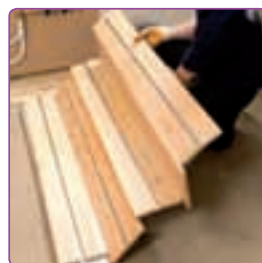
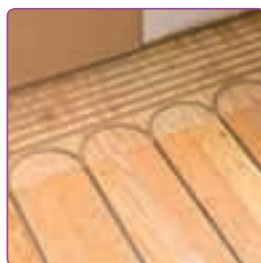
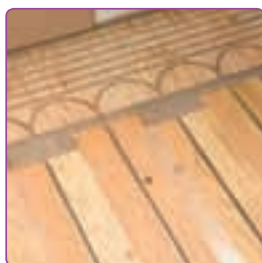



## Installation Instructions - Tracked Plywood Panel System



### Turn Panel or Feed & Turn Panel Installation

- After the straight panels have been fitted, it is time to install the header panels (Turn Panels or Feed & Turn Panels).
- Place the aluminium strips in the area where the header panels are to be installed.
- Trim aluminium strips, where necessary, with a pair of tin snips.
- Place the header panels so that they align with the grooves in the straight panels. Make sure to locate header panels to allow for a continuous pipe loop – see figures Fig 1 & Fig 2.
- Secure header panels in place; use 10 screws per panel to ensure that panels are securely fixed down.
- If necessary, Turn Panels can be cut to provide for single 90° or 180° bends.

### Final Floor Preparation

- To maintain an even floor height, 15mm plywood or chipboard (supplied by others) should be installed where underfloor heating is omitted, i.e. under baths, showers, kitchen units, etc. Timber panel off-cuts should be used as infill pieces at doorways, etc.
- When installing panels on a suspended wood floor, with pipe feeds in the joist space below the tracked panels, determine the location of the supply and return holes.
- Use a 18mm drill bit and drill 2 holes side by side. Then use a sharp wood chisel to square off the hole. Trim the aluminium backing plate out of the way. This will allow the 12mm pipe bend support to be located within the cut channel.
- Next, vacuum the whole area, especially the grooves in the tracked panels, to remove all debris.

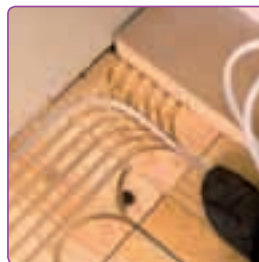
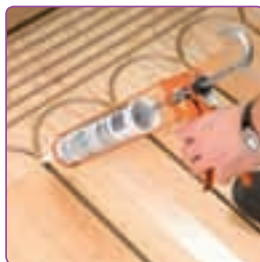

Fig 1. Incorrect



Fig 2. Correct

### Pipe Loop Installation



- Attach the first loop to the manifold at the supply connection.
- If the tails feed from under the floor, feed the pipe through the joist space before attaching to the manifold.
- Fit and position the bend support to the pipe where it rises out of the floor void to connect to the manifold.
- If feeding pipe tails from beneath the floor, connect another bend support to the pipe where it rises out of the floor void to enter the tracked panels.
- Lay down a 3 to 4mm bead of silicone sealant into the panel grooves.
- The sealant will become tacky in 8 to 10 minutes so only apply sealant to a section of panels that can be covered with pipe in this amount of time.
- Next, walk the pipe into the groove.
- Hard soled boots or shoes are recommended.

## Installation Instructions - Tracked Plywood Panel System

- If the pipe does not snap completely into the groove, first check to see if there is any obstruction under the pipe. If not use a rubber mallet to tap the pipe into place.
- Repeat the process of applying the silicone and walking the pipe into the groove until you reach the manifold, or the pre-drilled hole for taking the pipe into the joist space.
- Run the pipe to the return manifold connection and fit pipe bend supports as before.
- Repeat the procedure for all loops connected to this manifold.

### Inspection

Once the pipes have been laid, it is important to inspect the system before laying the floor, to ensure the installation is correct and pipes are held firmly away from any possible damage.

### Pressure Testing

Once all the pipes have been laid and connected to the manifold, fill and pressure test the system.

### Decking

The area should be decked, or covered, immediately to protect the system. Foot traffic must be prohibited until this is carried out to protect the pipes and panels. The final floor deck, and/or floor covering, should be installed as per the manufacturer's/supplier's instructions.



## UFH Installer Course

A two-day course at our purpose built facility in Lutterworth. The course is aimed at both new and experienced users of our products.

**Day 1** gives a thorough understanding of applications of UFH in our theory suite.

**Day 2** follows with practical exercises in our hands-on practical suite.



The Uponor Training Academy was established to offer you a range of industry accepted courses. Starting with a comprehensive installer training course and moving through to design and control oriented workshops, encompassing techniques associated with Uponor Plumbing and Underfloor Heating products.

We are also able to offer bespoke workshops, tailored to suit your individual needs. Our main training academy is a purpose built facility close to Junction 20 off the M1, in the market town of Lutterworth.



**Training Academy: 01455 551363**  
**Uponor Head Office: 01455 550355**  
**email: [training.uk@uponor.com](mailto:training.uk@uponor.com)**  
**[www.uponor.co.uk](http://www.uponor.co.uk)**

**ALSO SEE PAGE 118  
FOR OTHER COURSES  
AVAILABLE**



# Water Temperature Control



Water Temperature Control

Selection advice and installation guidance for your chosen water temperature control solution.

• Push 12 _____	36	• Uponor VPG & PPG control sets _____	40
• Compact Control Pack Version 5 _____	38	• Climate Controller _____	43



## Water Temperature Control - Push 12

Push 12	
12mm PEX	✓
16mm PEX	✓
20mm PEX	✓
16mm MLCP	✓

### Water Temperature Control for Underfloor Heating in one room

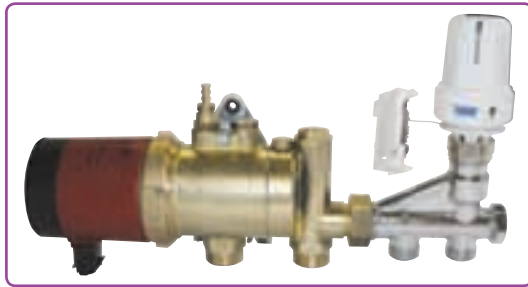

The Uponor Push 12 has been specially developed for small areas of underfloor heating in one room. It is designed to connect directly to the existing radiator system pipe work and supply one underfloor heating loop.

The Uponor Push 12 is designed to ensure that both the room temperature and the flow water temperature are maintained at a set level. A thermostatic valve (TRV) controls the water temperature in the underfloor heating system to suit the requirements of the room. An additional thermostatic valve is built into the pump housing to limit the temperature of the flow water in the underfloor heating loop. This special design ensures that both the room temperature and the flow water temperature are maintained at a set level.

The Push 12 is designed to be fitted directly to an existing radiator circuit. The water temperature in the underfloor heating loop must be lower than the water temperature in the radiator system. In order to obtain the required heat output, the flow in the underfloor heating loop must be greater than that in the radiator circuit. The Uponor Push 12 increases the water flow and controls the water temperature in the underfloor heating loop.

#### Installation

The Uponor Push 12 has been specially developed for use in conjunction with an existing radiator heating system, connecting directly to the existing pipework. It is supplied factory set for a two pipe system, but can easily be adapted to a single pipe system (see Figs. 1 and 2), and the setting on the thermostatic valve adjusted accordingly.

The air temperature sensor is supplied with a 2m capillary tube. The sensor should be fitted to the nearest available wall, preferably an inner wall. The thermostatic valve to which the sensor is connected (via the capillary tube), will automatically control the flow from the radiator circuit to ensure that the correct water temperature is supplied to the underfloor heating loops, achieving the desired room temperature.

The adjustable thermostatic valve has a temperature setting range of between 6°C and 27°C. To achieve a room temperature of approximately 20°C, the thermostatic valve should be set to number 3. An additional thermostatic valve is built into the pump housing in order to limit the water temperature in the underfloor heating loops. The balancing valve on the pump housing is used to set the pressure and flow in the underfloor heating loops.

If required, the thermostatic head and air sensor can be replaced with a 230 volt thermal actuator, which can then be controlled via a room or programmable thermostat.

In order to minimise any noise in the Uponor Push 12, the maximum recommended pressure drop in the valve should not exceed 30 kPa. Uponor recommend that, if the underfloor heating loop is to be installed in a bedroom or a bathroom, then the Push 12 should be fitted outside the room itself.

#### Maintenance

The Uponor Push 12 generally requires no maintenance. However, as a precaution it should be regularly inspected for leaks, and checked to ensure that the pump is not making any unusual noise. Excessive noise may be caused by air getting into the heating system. This can usually be resolved by turning the pump off, allowing the system to settle and then purging it of air through the air bleed valve (numbered 4 in schematic drawings overleaf), before re-starting it. Should the pump be inoperative for any length of time, check that the impeller on the pump is able to rotate freely by starting and stopping the pump several times. During the summer months, the pump should be inspected and run at least once a week, in order to ensure that it remains in good working order.

#### Selection Guide for 20mm Pex, m<sup>2</sup>

Output (Wm <sup>2</sup> )		
100	70	50
Maximum Loop Length (m)		
60	80	100
Maximum Floor Area (m <sup>2</sup> )		
17	23	29

**Note:** Areas based on pipe laid at 300mm c/c & dT of 8°C

#### Selection Guide for 16mm Pex, m<sup>2</sup>

Output (Wm <sup>2</sup> )		
100	70	50
Maximum Loop Length (m)		
60	80	100
Maximum Floor Area (m <sup>2</sup> )		
10	15	20

**Note:** Areas based on pipe laid at 200mm c/c & dT of 8°C

#### Selection Guide for 16mm MLCP, m<sup>2</sup>

Output (Wm <sup>2</sup> )		
100	70	50
Maximum Loop Length (m)		
50	75	100
Maximum Floor Area (m <sup>2</sup> )		
9	14	19

**Note:** Areas based on pipe laid at 200mm c/c & dT of 8°C

#### Selection Guide for 12mm Pex, m<sup>2</sup>

Output (Wm <sup>2</sup> )			
	100	70	50
Maximum Loop Length (m)			
	N/A	50	65
Maximum Floor Area (m <sup>2</sup> )			
Floating	N/A	6	7
Timber	N/A	8	10

**Note:** System12 Floating Floor at 8°C dT & 125mm c/c  
System12 Timber Panels at 10°C dT & 175mm c/c

### Underfloor heating in individual rooms made easy

The Uponor Push 12 is designed primarily to provide underfloor heating in a single room and room temperature control is provided only in the room in which the air temperature sensor is mounted. The Uponor Push 12 is further influenced by any central air temperature thermostat or programmer fitted to the radiator circuit which directly controls the operation of the boiler or heat source. The underfloor heating will only be "ON" when the radiator system is "ON". The thermostat or programmer may need to be adjusted to suit the underfloor heating system.

### Product Code

Item	Code
Push 12	<b>1059834</b>
Push 12 coupling set for 12mm PEX (x2)	<b>1002051</b>
Push 12 coupling set for 16mm PEX (x2)	<b>1057441</b>
Push 12 coupling set for 16mm MLCP (x2)	<b>1058090</b>
Push 12 coupling set for 20mm PEX (x2)	<b>1010629</b>
230V Programmable Thermostat (optional)	<b>1058425</b>
230V Thermal Actuator (optional)	<b>1022244</b>

### Basic diagram for a single pipe system

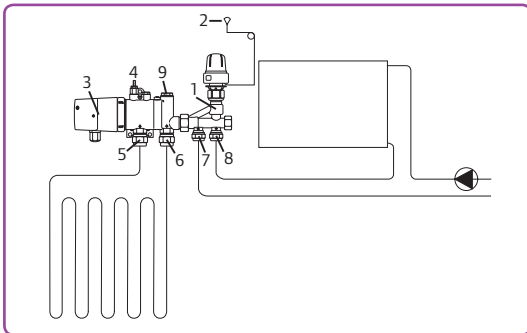

### Basic diagram for a two pipe system

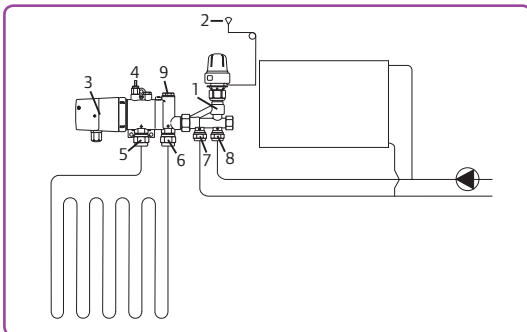

- 1) Thermostatic valve
- 2) Air temperature sensor with capillary tube
- 3) Circulation pump for underfloor heating loop
- 4) Air bleed valve
- 5) Flow connection to underfloor heating loop
- 6) Return connection from underfloor heating loop
- 7) Return to radiator heating system
- 8) Flow from radiator heating system
- 9) Balancing valve for regulation of pressure drop in underfloor heating system

### Pump diagram

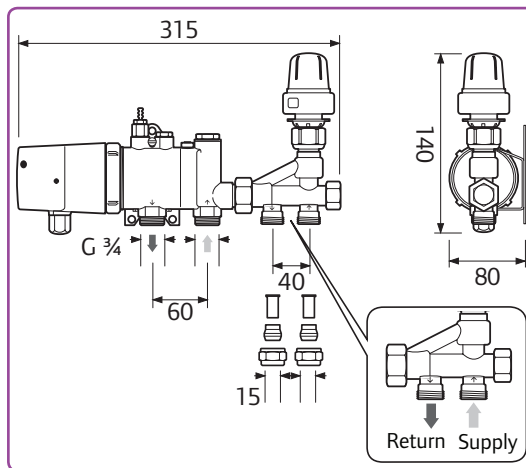
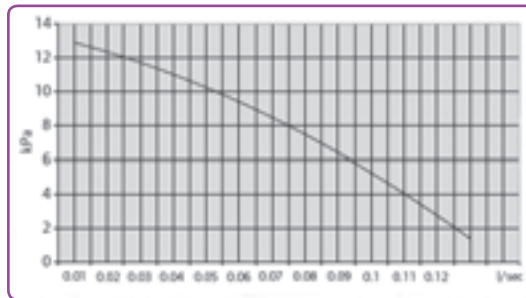

Distance from wall to centre pipe 43 mm. Total build depth 78mm. Radiator circuit connection  $\varnothing$  15 mm.



Electrical connection 1 x 230 V AC, 50 Hz, 0.11 A.



The LED indicates that the pump is connected to the electrical supply.

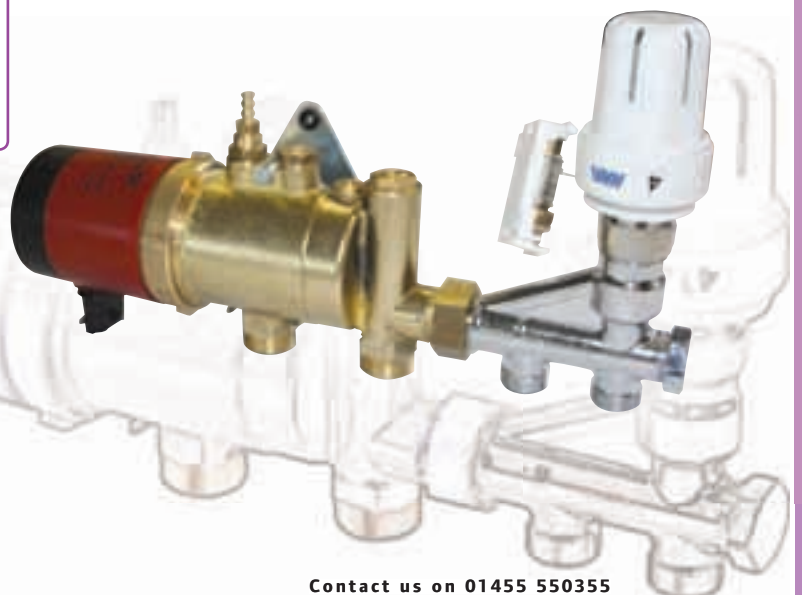

## Water Temperature Control - Compact Control Pack Version 5

CCPV5	
12mm PEX	✓
16mm PEX	✓
20mm PEX	✓
16mm MLCP	✓

### Installation Instructions

To reduce on site installation time the Uponor Compact Control Pack V5 is available pre-assembled to the Uponor TM Manifold (2-8 port). The following is intended to give the installer the necessary information to install the V5 Compact Control Pack when bought in its preassembled form. If a Compact Control Pack (CCP) and Manifold are purchased separately then the installation instructions included with the CCP should be consulted prior to installation.

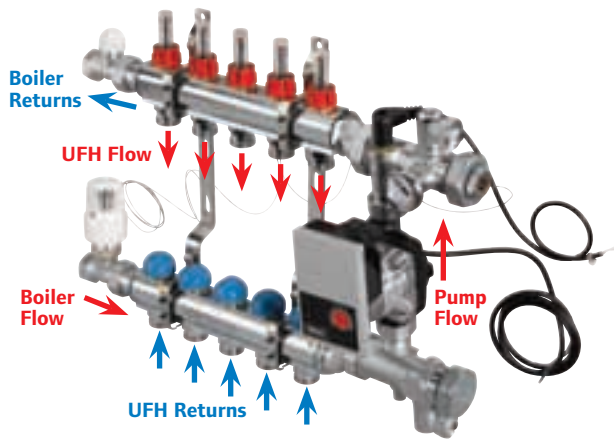

### Pack Contents

#### Main items:

- 1" Wilo 6m A - rated pump
- Thermostatic head and pipe sensor
- Preset immersion thermostat
- 2-port thermostatic valve body, 1" MT x 3/4" FT (BSP)
- Lockshield valve, 1" MT x 3/4" FT (BSP)
- Thermometer
- Manifold
- 1" connection set with integral pump isolation valve
- 1" connection set with immersion sensor pocket.
- 2 x fill and drain points

**Note, The pack does not include fittings to go from the manifold on to the UHF pipe work. These need to be ordered separately. The fittings used will have to be suitable for the pipe size and pipe type used.**

### Introduction

- The Uponor Underfloor Heating (UHF) Compact Control Pack is a "designed for purpose" solution for controlling the flow and temperature of water in systems with up to 200m<sup>2</sup> of active floor area and maximum 15kW heat load.
- The Control Pack comes pre-assembled on to the Uponor TM Manifold and is ready to be mounted on the wall straight from the box. It can also be supplied alone for coupling to LS manifolds and the larger size, 9 loops or more, TM manifolds.
- The thermostatic valve has a control head with a temperature adjustment range of 20 - 65°C.

### Operation

#### • During Heating Demand Periods

The Compact Control Pack is designed to mix the primary boiler flow water with the under floor heating return water. This is managed via a two port injection valve which is situated on the boiler flow which when open, allows the higher temperature boiler flow water to blend with the UHF return water in the return manifold. This maintains the required UHF flow temperature. An internal pipe sensor is fitted within the 90° elbow which operates the two port thermostatic injection valve.

A secondary pump then circulates the water around the UHF loops. To ensure that the majority of the water is forced around the UHF pipe network, a lock shield is positioned on the return back to the boiler which is used for balancing the system.

#### • High Limit Protection

The Compact Control Pack also includes a failsafe device. A high limit thermostat which is fitted to ensure that water exceeding 60°C does not flow around the UHF system as per BS EN: 1264 since high temperature water may damage floor coverings. This thermostat will operate, in the unlikely event of a high water temperature condition, to switch off the electrical supply to the UHF pump therefore preventing overheating and possible damage to the floor.

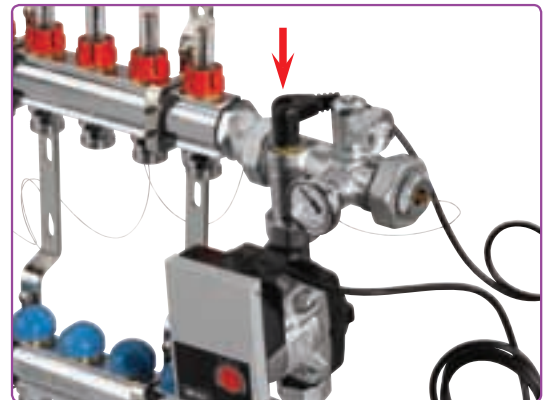

Approach temperature from heat source must be a minimum of 15°C above the required design flow temperature.

### Installation

- The unit is ready to be wall mounted straight from the box. Appropriate wall plugs and fixing screws should be used to do this. If there is not 100mm available to the right of the UFH pump then it is recommended that the injection valve head and immersion sensor are fitted prior to wall mounting the unit as per picture below.



- Fit the injection valve head on to the injection valve on the bottom left of the unit. The immersion sensor needs to be fitted into the pocket above on the connection set above the UFH pump. The grub screw should be tightened to ensure the sensor can not move.

**Note, it is possible to install the CCP V5 for either left or right hand primary pipe connection.**

- Primary flow & return pipes, to supply the UFH manifold, should be sized correctly, based on flow rate, pressure loss, and available pump duty. However, as a general guide we suggest the following sizes:

Manifold Size	MLCP/PEX (mm)			Copper (mm)		
	12	16	20	12	16	20
2 loop	16	16	16	15	15	15
3 loop	16	16	20	15	15	15
4 loop	16	20	25	15	15	22
5 loop	16	20	25	15	22	22
6 loop	20	25	25	15	22	22
7 loop	20	25	25	22	22	28
8 loop	20	25	32	22	22	28
9 loop	20	25	32	22	28	28
10 loop	25	32	32	22	28	28
11 loop	25	32	32	22	28	28
12 loop	25	32	32	22	28	28

### Wiring

- A suitable electrical supply is required.
- The immersion thermostat must be wired into the control circuit to cut out the electrical supply to the UFH circulator and two port zone valve in the event of a high limit condition.
- For individual room control systems the manual heads on the lower manifold are replaced with electro-thermal actuators. Uponor can supply various wiring/relay control units, including wireless control versions, to simplify the wiring for these types of installations.
- Uponor recommends that a 2-port motorised valve is used on the primary flow feeding the UFH manifold, a 'demand' from the UFH system will open the zone valve and the auxiliary switch should be wired to energise the boiler and

main system circulator.

- All wiring should be in accordance with the current edition of the IEE Regulations and any applicable Local Regulations.
- Refer to Mechanical and Electrical Schematics chapter for wiring drawings..

### Settings

- The thermostatic head is set to the required water flow temperature for the underfloor heating system, typical settings as follows:  
Screed floors: 40 – 45°C  
Wooden floors: 50 – 55°C
- The high limit thermostat does not need any adjustment. It is preset to 60°C.
- The lockshield valve needs to be opened so that it forces the majority of the water around the UFH system. The primary and secondary pump speeds, existing primary pressure and manifold size will affect how far open the lockshield valve needs to be.
  - To make an adjustment first unscrew and remove the white cap. Use the included Allen Key to adjust the valve.
  - To calibrate it is recommended that the lockshield valve is first fully closed and then opened until you see the thermometer continuously reading the same temperature as the setting on the injection valve head.
- Adjust the circuit flow rates by adjusting the flow regulators (topmeters) - see Starting-up and System Operation chapter.
- Pump setting: Set to maximum.



### Duty Table - Compact Control Pack V5

Heat Output (Wm <sup>2</sup> )		
100	70	50

PEX 20 Maximum Loop Length (m)					
80	100	100	120	120	160

Maximum Floor Area (m <sup>2</sup> )					
150	125	200	180	200	200

PEX 16 Maximum Loop Length (m)			
80	100	120	120

Maximum Floor Area (m <sup>2</sup> )			
140	200	145	200

MLC 16 Maximum Loop Length (m)			
75	100	120	120

Maximum Floor Area (m <sup>2</sup> )			
140	200	140	200

PEX 12 Maximum Loop Length (m)	
80	100

Maximum Floor Area (m <sup>2</sup> )	
120	120

#### Note:

- Pipes laid at 300mm c/c and dT = 7.5K for **PEX 20** pipes.
- Pipes laid at 200mm c/c and dT = 7.5K for **PEX 16/MLC 16** pipes.
- Pipes laid at 125mm c/c and dT = 7.5K for **PEX 12** Floating Floor.
- Pipes laid at 125mm c/c and dT = 10K for **PEX 12** Timber Panel System.



## Water Temperature Control - VPG & PPG Control Sets

VPG-10, PPG-20 & PPG-30	
12mm PEX	✓
16mm PEX	✓
20mm PEX	✓
16mm MLCP	✓

### Introduction

- The pre-assembled sets are designed for control of both water temperature and flow rates in secondary UFH circuits. All sets are robust and engineered for use in new and old domestic and commercial applications. The range of three sets gives flexibility to match individual project duties without compromising performance.
- The sets are supplied for left-hand primary connections. The VPG-10 can be handed by removing the brackets and rotating the pump through 180°. Right hand installation for both PPG-20 and PPG-30 is possible.
- Please read these instructions completely before commencing installation, this will reduce both initial setup and commissioning time.

### Set Contents

- Wilo A-Rated energy efficient pump
- 1" Ball valves with butterfly handles
- Brass interconnecting piping
- Mounting brackets
- Rubber lined pipe clips
- 1" Brass manifold ball valve connection set
- Manifold bracket spacer set
- Excenter fittings for direct manifold coupling (PPG-20 and PPG-30)
- Secondary water temperature immersion pocket (PPG-20 and PPG-30)
- Pre-wired Climate Controller and valve actuator (PPG-30)
- DUOmix TMV with electro-thermal actuator (VPG-10 only)
- 3-port rotary shoe valve (PPG-20 and PPG-30)

**Note: Climate Controller, 24v transformer and valve actuator for PPG-20 sold separately.**

VPG-10 with actuator  
(1061091)



PPG-20 (1059839)



PPG-30 (1059840)



### VPG and PPG Installation

- For future reference record the set name and batch number found on the box label.  
Set Product Name:
- In a majority of cases and as recommended, these instructions have been written assuming that the UFH manifold and VPG/PPG set will be coupled together..
- All fittings, except the pump unions, compression nut, brackets and manifold connectors, are supplied sealed with liquid thread sealing compound.
- When tightening fittings to the sets always ensure the liquid sealed components are sufficiently restrained to prevent rotation and breaking of thread seals.**
- Identify all components and ensure adequate space for mounting the set is provided.
- The PPG sets are supplied at a pitch of 175mm and both come with excenter fittings that enable them to be directly coupled to our TM/LS manifolds which have a pitch of 225mm. The VPG-10 however is supplied at a pitch of 225mm and does not require any additional fittings.

Please follow the installation procedure below:-

- Apply thread sealant to the 1" BSPM end of the manifold connection sets and fit to the manifold ball valves.
- Remove the plastic dust caps from the manifold connections of the VPG/PPG and offer the VPG/PPG assembly up to the manifold and mark the bracket fixing locations.
- Lay the VPG/PPG aside and prepare the wall fixings, (not supplied), then fix the VPG/PPG to the wall.
- Insert the fibre washers between the manifold connection set flanges and the VPG/PPG and tighten the swivel nuts.
- Ensure the pump shaft is horizontal by loosening and retightening the pump unions. See pump installation instructions for further details.

### VPG-10, DUOmix Actuator Installation

- Prior to fitting the valve actuator, the temperature setting of the TMV requires adjusting using a 10mm spanner.
- The fully down/clockwise rotated position corresponds to the minimum temperature setting of 35°C, and the fully up/anticlockwise rotated position corresponds to the maximum setting of 60°C.

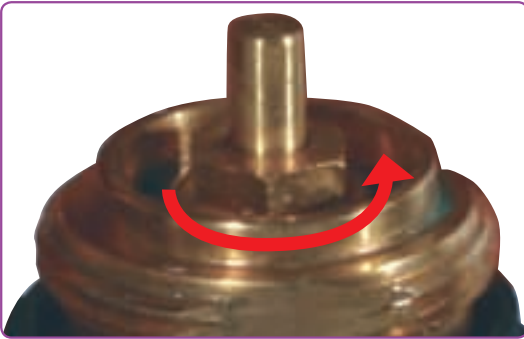

- For intermediate temperature settings rotate the nut anticlockwise from the fully down position through an angle of 60° (one nut flat) for approximately every 4°C temperature rise required, see table below.

#### Rotation from fully closed (60° is one nut flat)

0°	60°	120°	180°	240°	300°	360°
35	39	43	48	52	56	60

Approx. mixed flow temp. °C

- Typically, the maximum water temperature setting for solid floors is 45°C and 60°C for timber suspended and floating floors.
- To install the actuator, position over the valve head and apply a downward pressure to compress the pin and hand tighten the actuator swivel nut. The primary hot port is now in the closed position until the actuator is energised, as shown by the actuator indicator.



### PPG-20, Motorized Valve Actuator Installation

- The PPG-20 is designed for use with the Climate Controller (product code 1047844) and 24V valve actuator (product code 1002356); both are ordered and supplied separately.
- Set the valve shaft in the mid-position of the scale plate, between the 9 and 12 o'clock position, and remove the handle without changing the position of the valve spindle.

**Note: A separate 24V power supply is required (product code 1048762).**

- Place the white sleeve on the spindle.
- Screw the actuator ant-rotation stud into its position beneath the valve cover plate.

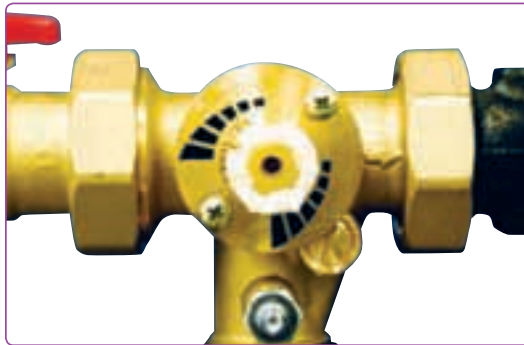

- Fit the actuator to the valve by removing the actuator knob, and securing together with the central screw. Refit knob back on the actuator - red line indicator should be pointing to the 3 o'clock position.
- Fit the red plastic scale to the actuator cover directly above the knob. Use the one with the larger scale to the left-hand side.
- Should manual operation of the valve be required simply pull and twist the knob in the desired direction.

### Remote Coupling of Set and Manifold(s)

- The set can be used for supplying mixed water to a remote manifold(s).
- Like the primary system, the correctly sized interconnecting pipe size between the set and manifold(s) is essential for satisfactory operation of the UFH system.
- The area served by a set, as given in the Selection Guide, will be reduced when remotely coupling the mixing set and manifold(s), as some of the pump head will be used to overcome the interconnecting pipe pressure loss.
- For further advice on remote coupling and interconnecting pipe sizes please refer to the Uponor Technical Department (See telephone number on back page).



## Water Temperature Control - VPG & PPG Control Sets

**Duty Table - VPG-12-TH Pump Group**

Heat Output (Wm <sup>2</sup> )					
100	70	50			
PEX 20 Maximum Loop Length (m)					
80	100	100	120	120	160
Maximum Floor Area (m <sup>2</sup> )					
130	120	185	170	260	160
PEX 16 Maximum Loop Length (m)					
80	100	120	120		
Maximum Floor Area (m <sup>2</sup> )					
130	185	140	260		
MLC 16 Maximum Loop Length (m)					
75	100	120	120		
Maximum Floor Area (m <sup>2</sup> )					
130	185	115	260		
PEX 12 Maximum Loop Length (m)					
	80	100			
Maximum Floor Area (m <sup>2</sup> )					
	120	120			

**Duty Table - PPG-30 Pump Group**

Heat Output (Wm <sup>2</sup> )			
100	70	50	
PEX 20 Maximum Loop Length (m)			
100	120	120	160
Maximum Floor Area (m <sup>2</sup> )			
300	430	600	600
400*	575*	800*	800*
PEX 16 Maximum Loop Length (m)			
80	100	120	120
Maximum Floor Area (m <sup>2</sup> )			
300	430	370	600
400*	570*	495*	800*
MLC 16 Maximum Loop Length (m)			
75	100	120	120
Maximum Floor Area (m <sup>2</sup> )			
300	430	350	600
400*	570*	465*	800*

\* dT = 10K

**Duty Table - PPG-20 Pump Group**

Heat Output (Wm <sup>2</sup> )					
100	70	50			
PEX 20 Maximum Loop Length (m)					
80	100	100	120	120	160
Maximum Floor Area (m <sup>2</sup> )					
175	160	250	230	350	300
PEX 16 Maximum Loop Length (m)					
80	100	120	120		
Maximum Floor Area (m <sup>2</sup> )					
175	250	185	350		
MLC 16 Maximum Loop Length (m)					
75	100	120	120		
Maximum Floor Area (m <sup>2</sup> )					
175	250	155	350		

**Note:**

- 1) Pipes laid at 300mm c/c and dT = 7.5K for **PEX 20** pipes unless specified otherwise.
- 2) Pipes laid at 200mm c/c and dT = 7.5K for **PEX 16/MLC 16** pipes unless specified otherwise.
- 3) Pipes laid at 125mm c/c and dT = 7.5K for **PEX 12** Floating Floor.
- 4) Pipes laid at 175mm c/c and dT = 10K for **PEX 12** Timber Panel System.

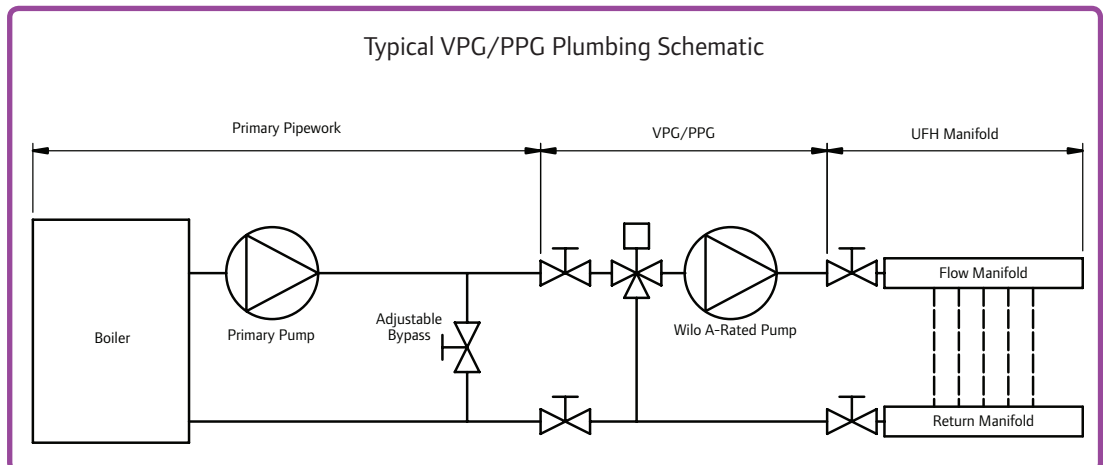

## Water Temperature Control - Climate Controller

The Climate Controller is flexible, easy to install, simple to operate and designed to achieve optimum results.

### The Uponor Climate Controller .....

- a fixed water temperature controller
- a weather compensator
- suitable for heating only applications
- suitable for combined heating and cooling applications
- configurable for ice and snow melt applications
- able to work stand alone (with basic sensors)
- able to co-operate with the wired system (heating/cooling switchover)
- able to co-operate in an integrated and enhanced way with the Radio Zone Controller and Interface



Climate Controller	
12mm PEX	✓
16mm PEX	✓
20mm PEX	✓
16mm MLCP	✓

The Uponor Climate Controller is a piece of advanced technology, yet simplifies the installation task and is intuitive for the end user.

Once connected, the installation wizard guides you through the system set-up. By following the on screen instructions it is configured in almost no time.

And it won't take long to instruct your customer, either! The quick menu makes it easy to find the settings and handle the Uponor Climate Controller.

The Uponor Climate Controller provides room temperature control for a comfortable thermal environment.

- Installation wizard allows fast and easy fit
- Quick menu system provides easy access to basic settings
- Automatic summer/winter time change
- ECO/Comfort timer
- Integrates water temperature with room temperature controls or can operate in stand alone mode



The installation wizard gives on-display-guidance, making installation fast and easy for you.

### Heating Mode

- Heating mode requires:** Climate Controller c/w Supply Water Temperature Sensor and Outdoor Sensor (Product Code: 1047844).
- Optional:** Antenna module for connection to wireless thermostats  
Wired Indoor Sensor (Product Code: 1047848)  
Wired Return Sensor (Product Code: 1047847)

The Climate Controller can be setup to control heating in a number of different operating modes, which will depend on the sensors connected. The table below shows sensors used for each operating mode.

Operating mode	Supply sensor	Outdoor sensor	Indoor sensor	Return sensor	Relative humidity sensor	Floor sensor
Heating - fixed supply	○					
Heating - outdoor controlled supply	○	○				○
Heating - outdoor controlled supply with indoor compensation	○	○	○			
Heating - outdoor controlled average	○	○		○		
Heating - indoor controlled	○		○			

In the majority of installations, heating with outdoor controlled supply (commonly known as weather compensation) will be the chosen operating mode. For this arrangement all required sensors are contained in the standard Climate Controller pack. To gain maximum benefits of energy efficiency and communication between water and room temperature controls, use the Climate Controller to interface with Uponor Radio Zone controller and/or wireless room thermostats.

## Water Temperature Control - Climate Controller

### Heating and Cooling Mode

**Heating and Cooling mode requires:** Climate Controller Extended version c/w Antenna, Wireless Humidity Sensor H-56, Supply Water Temperature Sensor and Outdoor Sensor (Product Code: 1047845).

**Optional:** Wired Indoor Sensor (Product Code: 1047848)  
 Wired Return Sensor (Product Code: 1047847)  
 Up to 5 additional wireless Relative Humidity Sensors (Product Code: 1047846)

In addition to heating control, the Climate Controller can maintain design water temperature for cooling systems together with summer/winter switchover.

Operating mode	Supply sensor	Outdoor sensor	Indoor sensor	Return sensor	Relative humidity sensor	Floor sensor
Cooling - fixed supply	●					○
Cooling - indoor controlled	●		●			○
Cooling - indoor compensated supply with dew point control	●		●		●	○

For combined floor heating and floor cooling systems, cooling with indoor compensated supply with dew point control is the recommended operating cooling mode. The relative humidity sensor(s) should be located to minimise the risk of condensation within the building.

Item	Description
-	Climate Controller
-	Relative Humidity Sensor (only used in cooling systems with dew point control)
-	Radio Public Thermostat
-	Radio Dial Thermostat
-	Radio Digital Thermostat
1	Radio antenna
2	Outdoor sensor
3	Indoor sensor
4	Supply sensor
5	Return sensor
6	Circulation pump
7	Mixing valve actuator <ul style="list-style-type: none"> <li>• Thermal. 24V DC, 3W, NC (See illustration)</li> <li>• Motorized, 0-10V DC, externally powered</li> </ul>
8	H/C switchover relay box (only used in heating/cooling switchover systems)
9	Diverting valve (only used in cooling systems with dew point control)
10	Pipes to heating source
11	Pipes to cooling source

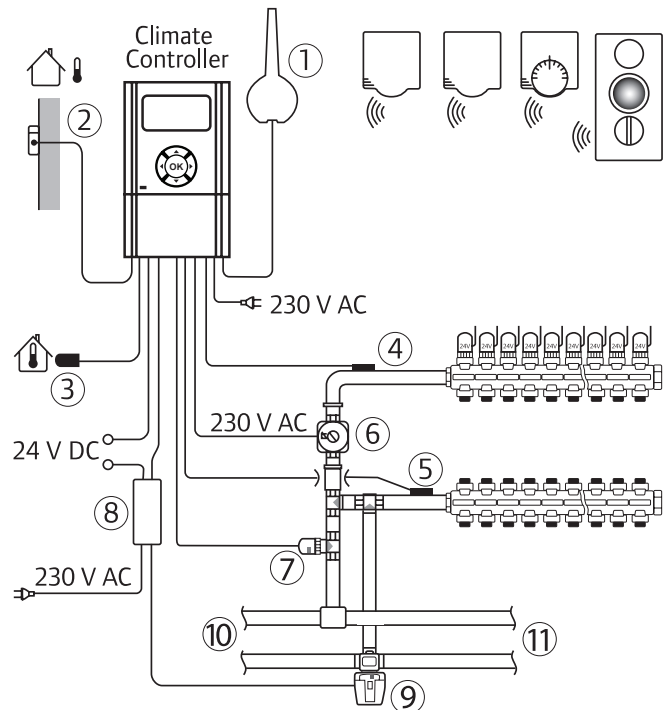

The Climate Controller features heating/cooling switchover, which can be controlled by the Radio Zone Controller controller when using Uponor radio room temperature controls.



## Meltaway Mode

**Meltaway mode requires:** Climate Controller c/w Supply Water Temperature Sensor (Product Code: 1047844) and Return Water Temperature Sensor (Product Code: 1047847)

Climate Controller can be used to control the water temperature to a Meltaway (Snow or Ice Melt) System. The Climate Controller can be wired to a timer and push button for simple manual activation, alternatively, a dedicated Meltaway controller with snow-and-ice sensor can be used for fully automatic operation.

Item	Description
-	Climate Controller
1	Simplified meltaway using timer and push button (alternative solution)
2	Meltaway controller with snow-and-ice sensor (alternative solution)
3	Supply sensor
4	Return sensor
5	Circulation pump
6	Mixing valve actuator <ul style="list-style-type: none"> <li>• Thermal (See illustration)</li> <li>• Motorized, externally powered</li> </ul>
7	Pipes to meltaway system
8	Pipes to heating source

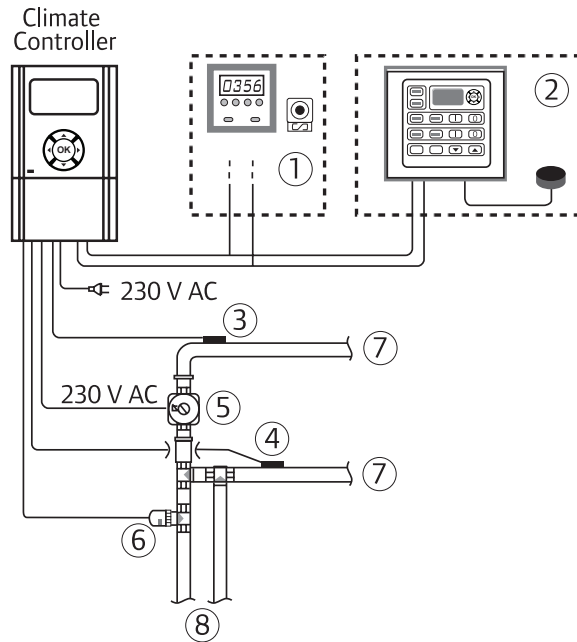

# Uponor Controls at a glance



## Wireless

- Control up to 36 zones through one interface
- Up to 12% energy saving due to better efficiency
- No manual balancing
- More accurate control
- Improved heat distribution
- Easy to operate
- Auto-balancing, no recalculation required
- Easy trouble shooting
- Changing the floor covering will not affect the system



## Wired 12V

- Can control up to 12 zones
- Economical and secure low voltage thermostat cabling
- Range of thermostats to choose from
- Thermostats can be connected to a floor sensor
- Auto-balancing, no recalculation required. Digital Thermostats only.
- Setpoint values can be limited



## Wired 230V

- Surface or flush mounted thermostats available
- Controls up to 8 zones and 16 thermal actuators
- 2 Channel set back time control
- Choice of programmable or non programmable thermostats
- Thermostats can be connected to floor sensors



# Uponor Heating & Cooling Controls



Uponor individual room and supply temperature controls, combined with our radiant heating and cooling solutions, provide comfortable ambient temperatures all year round.

- **Wireless Controls** \_\_\_\_\_ 48
- **Wired Controls** \_\_\_\_\_ 49
- **230V Wired Controls** \_\_\_\_\_ 51

## Room Controls

With underfloor heating (UFH), the basic principles of domestic thermostatic control remain the same. The floor of a room can be considered to be a large low surface temperature radiator, but instead of a self-regulating thermostatic radiator valve to provide room temperature control, a room thermostat is used to open and close a loop(s) on the UFH manifold. Alternatively, a single room sensor or programmable room thermostat can be used to control the UFH as a single zone.

Uponor recommends that all UFH systems are equipped with room temperature controls, to optimize operating efficiency of the heating system and provide for the flexibility of independent control to each room or heating zone.

### Uponor offers two options for individual room control:

1. **Wireless controlled room thermostats.**
2. **Hard wired room thermostats.**



### Wireless Control

Wireless Control is Uponor's preferred system for multi-zone installations. Wireless thermostats can be located almost anywhere within the room and easily relocated if necessary. No planning or cost for routing cables to thermostats simplifies the electrical installation. As well as standard wireless thermostats Uponor have developed a Premium version which more effectively measures thermal comfort, increase comfort and energy efficiency. The Wireless Controller is a wiring centre with in-built relay logic that requires a 230 volt electrical supply and has an on board 230V/24V transformer for connection of 24V thermal actuators and Control Interface Unit. Each room or zone is equipped with a room thermostat, which signals to open/close the thermal actuators fitted to the respective heating loops on the manifold. 12 wireless thermostats and 14 thermal actuators can be connected to each wireless controller. While the Interface unit can manage up to 3 Controllers.

#### Wireless Control Components

##### Wireless Zone Controller



##### NEW! Featuring Dynamic Energy Management - up to 12% energy saving!

Designed for receiving and interpreting radio signals from a maximum of 12 wireless thermostats. In built 230-24V transformer, two relays and can control up to 14 x 24V actuators. Time controlled setback is available via the Wireless Zone Interface Controller (1046083).

- Easy wireless installation of thermostats
- LED for each channel indication on/off/alarm
- The majority of the wiring is possible without tools
- Connections for Interface Unit (I-76, see next section)
- Pump/Valve exercise function
- Lightweight unit

Description	Code	Qty
Controller	<b>1045567</b>	1

##### Wireless Zone Interface Controller



##### NEW! Featuring Dynamic Energy Management - up to 12% energy saving!

The Interface can be used to control a maximum of three wireless Zone Controllers (1045567). The unit offers 5 temperature setback programs and comes complete with cable for connection to the Controller. Features include holiday mode, assignment of room names, display of all setpoint and actual room temperatures and valve and pump exercise functions.

- Holiday temperature
- Automatic summer/winter change over
- Set room names (kitchen, Living etc.)
- Five temperature setback programs
- Different access levels (Basic/Advanced/Installer)
- Max/min temperature limitations
- The interface can control up to three controllers
- Pump management settable to "Individual" or "Common"

Description	Code	Qty
Interface	<b>1046083</b>	1

##### Wireless Digital Thermostat



Push button operation for temperature control from +5°C to +35°C. Allows the user to view the current ambient temperature or the set point temperature via the LCD display.

Two standard AAA batteries are included.

- LCD display
- Push buttons for setting
- Sensor for operative temperature (measures radiant and convective heat)
- Easy wireless registration
- Available in white, silver or grey
- Set point range 5-35°C
- Low battery indication

Description	Code	Qty
White	<b>1000502</b>	1
Silver	<b>1000504</b>	1
Grey	<b>1046114</b>	1

Refer to Uponor Control System Installation and Operation Manual for detailed instructions.



### Wireless Dial Thermostat



- Dial for setting
- Sensor for air temperature
- LED indication for "Radio transmission" and "Low battery"
- Easy wireless registration
- Set point range 6-30°C, mark at 21°C
- Setting range can be limited mechanically by adjusting pins under the dial

Description	Code	Qty
White	1058385	1

### Wireless Public Thermostat



- Plain cover with internal setting
- Sensor for air temperature
- LED indication for "Radio transmission" and "Low battery"
- Easy wireless registration
- Set point range 6-30°C
- Terminals for connection of a room sensor
- Terminals for connection of a max/min floor sensor

Description	Code	Qty
White	1045572	1

### Wireless Controller Remote Access Module



Allows remote access to switch between Eco or Comfort settings. Very useful for holiday homes. Gives updates; indoor temperature and outdoor temperature - requires a Wireless Public Thermostat (1045572)  
 Note: will require a SIM card, not provided.

Description	Code	Qty
Remote Access Module	1046485	1

### Wired Control

Uponor's hard-wired control system, for multi-zone applications, incorporates a transformer housed within the Controller. This provides low voltage power to the thermostats and thermal actuators. 3 room thermostat options are available including 2 with max/min limitation of floor temperature with a floor sensor connected. Each room or zone is equipped with a room thermostat, which opens and closes the thermal actuators fitted to the respective heating loops on the manifold. A 2 channel remote timer can be connected to allow programming of times for automatic setback of room temperatures.

#### Wired Control Components

### Wired Zone Controller



The Wired Controller is a relay/wiring centre that can control up to 14 x 24V actuators via a maximum of 12 hard wired room thermostats. The unit has an in built 240-24V transformer with two relays; one to send a demand signal to the heat source or water temperature control unit and one for a dedicated underfloor heating pump (if required). Additional features of this unit include:

- Pump/Valve exercise function
- Connections to connect to an external timer unit, wired controller timer
- The majority of the wiring is possible without tools
- Power LED
- Lightweight unit

Description	Code	Qty
230/24V Controller	<b>1000534</b>	1

### Wired Controller Timer



The Timer (I-36) is designed to offer Night Set Back (NSB) of the internal room temperatures when used in conjunction with the Controller Wired (C-35). The Night Set Back control increases the responsiveness of the system by ensuring the system is not allowed to cool below an acceptable level by maintaining a lower temperature during unoccupied times. The unit itself has navigation buttons situated around a large LCD making using and programming straight forward. Additional functions include:

- Holiday temperature
- Two temperature setback programs
- Optional summer/winter time change
- Remote controlled economy mode, which requires additional SMS module (1046485) or other third party hardware.

Description	Code	Qty
White	<b>1048013</b>	1

## Room Controls

### Wired Control Components

#### Wired Public Thermostat



The thermostat dials are hidden by a cover which needs to be removed before adjustments can be made. The Public Thermostat also allows control over the minimum or maximum floor temperature when used with a floor sensor (1000538).

- Plain cover
- Internal setting
- Sensor for air temperature
- Set point range 6-30°C
- Max/Min limitation with floor sensor

Description	Code	Qty
White	1000537	1

#### Wired Dial Thermostat



Easy-to-use thermostat that incorporates conventional thumb wheel control to adjust the air temperature set point. The setting range can be limited mechanically by adjusting pins under the thermostat dial. A floor sensor can be wired to the thermostat which will give it the ability to control the minimum or maximum floor temperature (1000538).

- Dial for setting
- Sensor for air temperature
- LED for indication
- Terminal for floor sensor (internal setting for floor sensor)
- Set point range 6-30°C, mark at 21°C
- Setting range can be limited mechanically by adjusting pins under the dial

Description	Code	Qty
White	1058387	1

#### Remote Floor Sensor



Floor sensor attached to a 4m cable for use with the thermostats to enable control over the maximum or minimum floor temperature.

Description	Code	Qty
4m	<b>1000538</b>	1

#### Wired Digital Thermostat



- Large LCD display
- "Auto-balance" function available. No manual calculation or balancing required
- Comfort and Eco setting via the i-36
- Heating or Cooling demand display
- Min/Max limitation for both air and floor
- Optional floor sensor can be connected
- Temperature calibration function
- Lock facility – tamper proof
- Condensation warning (Cooling mode)
- Floor sensor fault display

Description	Code	Qty
White	<b>1048011</b>	1

#### Wired Programmable Digital Thermostat



- Large LCD display
- 5/2, 6/1, 7 day programmable groups
- Up to 5 Comfort/Economy changeovers per day
- "Auto-balance" function available. No manual calculation or balancing required
- Holiday temperature setting
- Heating or Cooling demand display
- Min/Max limitation for both air and floor
- Optional floor sensor can be connected
- Temperature calibration function
- Lock facility – tamper proof
- Condensation warning (Cooling mode)
- Floor sensor fault display

Description	Code	Qty
White	<b>1048012</b>	1

Refer to Uponor Control System Installation and Operation Manual for detailed instructions.

## 230V Wired Control Components

### 230V Wired Control

Uponor's 230 V hard wired control system, for multizone applications, provides mains voltage power to the thermostats and actuators. 2 room thermostat options available, digital programmable or dial type with digital temperature display. Both thermostats have the ability to regulate floor temperature through floor sensors. 4°C Night temperature setback is also available for the dial thermostat by using our single channel time clock, the 8 way control box can handle 2 setback time zones via remote time clock(s).

### 230V Wiring Centre



The 8 way controller is a relay/wiring centre that can control up to 16 x 230 V actuators via a maximum of 8 hard wired thermostats (230 V). The unit has two relays; one to send a demand signal to the heat source or water temperature control unit and one for a dedicated underfloor heating pump (if required).

#### Additional features of this unit include:

- Setback temperature with connection for up to 2 timers, or via BMS.
- Open system
- 2 volt free contacts for UFH pump and heat demand
- Lightweight unit
- Replaceable fuse
- 230 V wiring throughout

Description	Code	Qty
White 230V	<b>1047456</b>	1

### 230V Digital Programmable Thermostat



- Fully programmable 5/2 or 7 day with four heat levels per day
- Multiple regulation control choice: air only, air and floor or floor only
- Holiday mode with override feature
- Optimised start
- Lock facility/tamper proof setting
- 35mm pattress box required

Description	Code	Qty
White 230V	<b>1058425</b>	1

### 230V Digital Dial Thermostat



- 4°C night setback
- Multiple regulation control choice: air only, air and floor or floor only
- Lock facility/tamper proof setting
- Heat demand indicator

Description	Code	Qty
White 230V	<b>1047457</b>	1

### Room Thermostat Mounting

Thermostats are generally mounted approximately 1.5m above floor level, away from draughts, direct sunlight or any other direct heating outlet which could affect the reading. If a room is likely, presently or sometime in the future, to be used by a wheelchair user then thermostat mounting height should be lowered to between 1 to 1.2 metres. An advantage of radio thermostats is that they can easily be repositioned within the room to suit any change in room use.

### Thermal Actuators

Thermal actuators are fitted onto the UFH manifold and provide for automatic control of individual heating loops. They have an open and closed indicator window and take between 2–4 minutes to completely open.

### Integration with Uponor Water Temperature Controls

The Uponor electronic control systems can easily be integrated with the Uponor range of water temperature control sets, including the 'V5 Compact Control Pack', 'VPG/PPG' and the 'Climate Controller'. See electrical wiring details in Mechanical and Electrical Schematics chapter.

### Single Zone Control

All water temperature controls supplied for a single zone application will be offered with a programmable room thermostat. This will provide both time and temperature control. See electrical wiring details.

For full installation and user instructions refer to the manuals enclosed with each item (additional copies available on request).

# Easy control for individual comfort

## Ideal room temperatures every month of the year

Everyone perceives temperature differently. During summer and winter, maximum thermal comfort can only be reached if the environmental temperatures satisfy the needs of the user.

This requires a flexible and sensitive control system. Uponor offers exactly this, ranging from room thermostats to controllers and heating manifolds, all from one source.

A feeling of well-being in our surroundings can only be achieved when all components fit perfectly with each other.

The innovative systems from Uponor for individual room and supply temperature control, combined with Uponor radiant heating and cooling solutions, provide comfortable ambient temperatures all year round, together with ease of use.



Patented technology unique to Uponor. Auto balance technology continues balancing through sun, wind and frost; through the changing seasons and through the household's changing lifestyle and usage patterns.

**Up to 12%**  
**Energy Saving!**

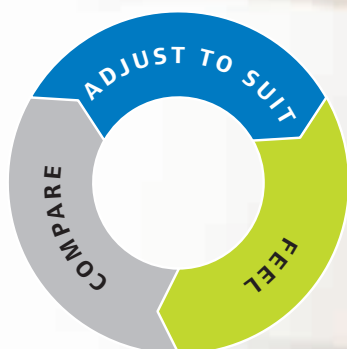

Control cycle for thermal comfort













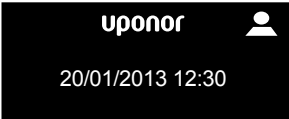



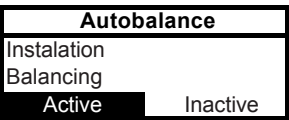

# Uponor Room Control User Guide

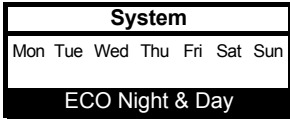

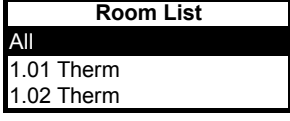

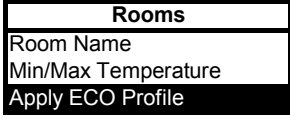

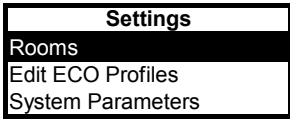





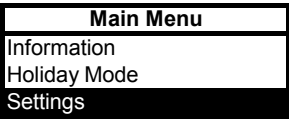

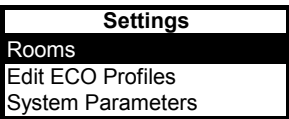

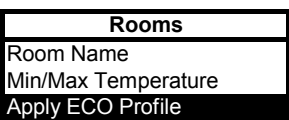

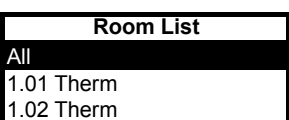
Step by step guide for Uponor individual room controls

- Wirell Zone Interface \_\_\_\_\_ 54
- Wired Programmable Digital \_\_\_\_\_ 56
- Wired Zone Timer \_\_\_\_\_ 58
- Wired Digital Thermostat \_\_\_\_\_ 60
- 230V Digital Programmable Thermostat \_\_\_\_\_ 61





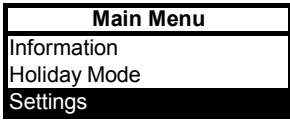

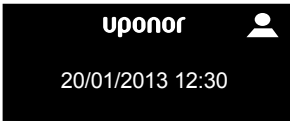









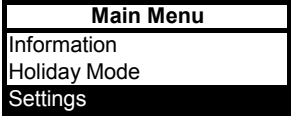

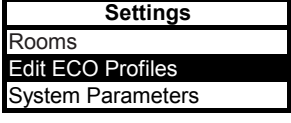



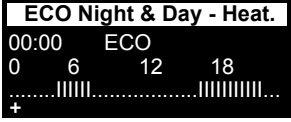

## Wireless Zone Interface First Time Start up

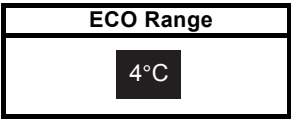
1.  
2.   
3.  
4.  
11.  
12.  
13.  
14.  

To edit **ECO Profiles**, see page 55 opposite, then follow steps below to apply.

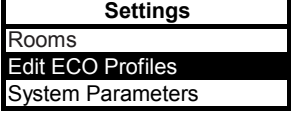
5.   
6.  
7.   
8.  
9.   Use **down** arrow to put marker against each day.  Use **right** arrow to move to next day.  Hold **down** arrow until ECO profile list appears.
10.   
15.  
16. 

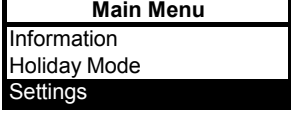
## How to edit your time and temperature schedule (ECO Profile)

1.   If the user icon in the right hand corner appears without a + symbol then perform the following key press sequence. Press and hold the **left** and **right** directional arrows simultaneously until the word "Advanced" appears.
2.   Press **OK** to accept access level change.
3.   Press **OK** to enter main menu.
4.    Select settings and press **OK**
5.    Select Edit ECO Profiles and press **OK**
6.    Select the profile that you are currently using and press **OK**
7.    The time line displays the Eco and Comfort schedule, Comfort is indicated by the long line and ECO by the short line. Move the cursor (+) along the time line and toggle between either Comfort or ECO by using the **up** and **down** arrows. When you have finished editing the chosen ECO profile press **OK** to accept.
8.   The temperature shown here is the reduction below the comfort setpoint when an ECO event occurs. For example a setpoint temperature of 21°C in comfort mode would give an eco setpoint temperature of 17°C (based on a 4°C eco range). When you have selected the required ECO range press **OK** (Uponor recommends a 4°C ECO range).
9.   Use **left** hand arrow to exit menu.
10.   Use **left** hand arrow to exit menu.  
*If you have modified a different profile to the one that you are currently using and wish to apply it then please follow step 6 onwards from the wireless zone interface setup page.*
11.   Use **left** hand arrow to exit menu.
12. 

**Please see chapter 9 of the installation and operation manual for further detailed information on programming and operating the wireless zone interface.**

## Wired Programmable Digital Thermostat



1. Start up screen.

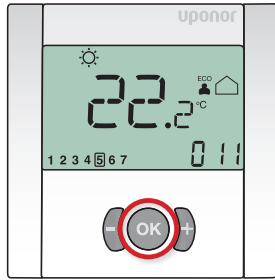

2. **Display screen.** Press and hold OK until screen 3 appears.

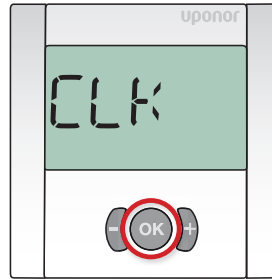

3. Press OK once to enter clock menu.

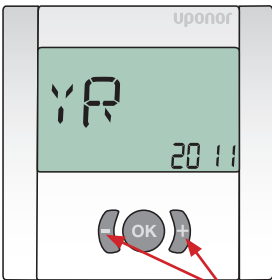

4. Adjust year using + or -, confirm by pressing OK.

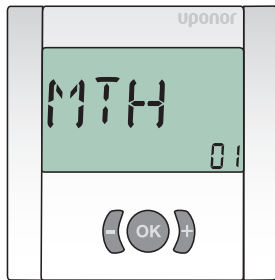

5. Select month 01 = Jan, confirm by pressing OK.

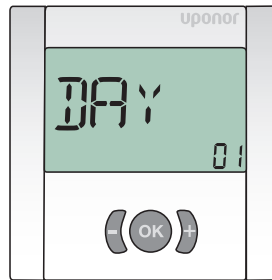

6. Select day of the month and confirm by pressing OK.

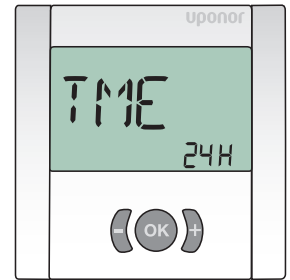

7. Choose between 24hr or 12hr time clock, confirm by pressing OK.



8. Adjust to correct time confirm by pressing OK.



9. Confirm automatic summer winter time, change by pressing OK.



10. Enter programming menu by pressing OK.



11. Select programming ON by pressing OK.



12. Select schedule group. Press + or - successively to select the group of days. There are three alternatives:

- 1 2 3 4 5 6 7 Monday till Friday, default setting.
- 1 2 3 4 5 6 7 Monday till Saturday.
- 1 2 3 4 5 6 7 Monday till Sunday.

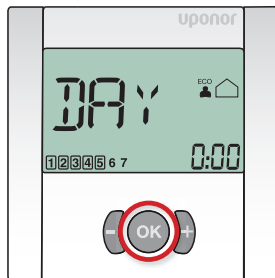

13. To accept the default setting press and hold the OK button for 3 seconds. Repeat for Z2 and subsequent group day(s) if applicable.

Default Schedule Mon - Fri:  
 05:00 – 08:00 Comfort  
 08:00 – 17:00 Eco  
 17:00 – 22:00 Comfort  
 22:00 – 05:00 Eco

Default Schedule Sat –Sun:  
 06:00 – 23:00 Comfort  
 23:00 – 06:00 Eco

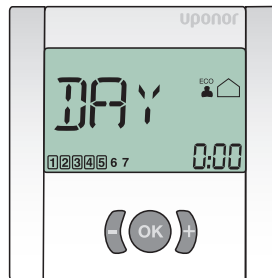

14. For user defined ECO and Comfort schedule please follow screen steps 14 - 20. Press the + button until you reach the desired time for comfort operation.



15. Example shows 6am as the chosen comfort event. Press OK to put the person in the house.





**16.** Example shows 9am as the next chosen ECO event. Press OK to take the person outside of the house.

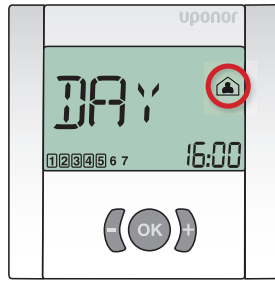

**17.** Example shows 4pm as the next comfort event. Press OK to put the person inside the house.

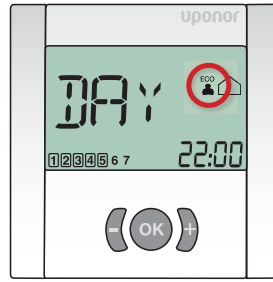

**18.** Example shows 10pm as the next ECO event. Press OK to take the person outside of the house.

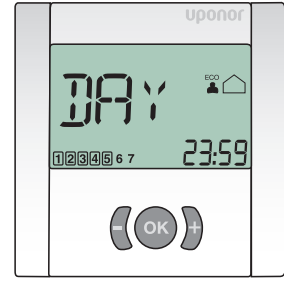

**19.** Press the + button until 23:59. Leave until screen 20 appears.



**20.** Repeat process for days 6 & 7 if applicable.

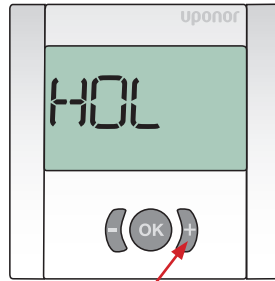

**21.** Press the + button once to scroll to next menu.

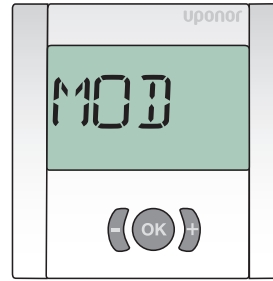

**22.** Enter MOD menu by pressing OK.

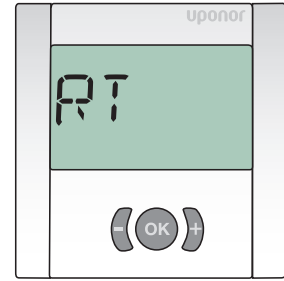

**23.** Select RT (room thermostat) using the - & + button and press OK. For further information on different modes please refer to section 9.5 page 28 of the Wired System operation and installation manual.



**24.** Enter BAL menu by pressing OK.

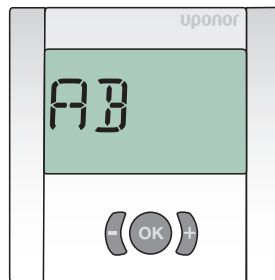

**25.** Select AB and press OK.

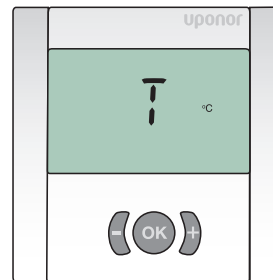

**26.** Press OK to enter comfort and ECO temperature settings.

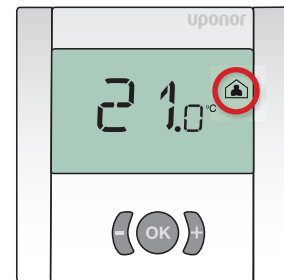

**27.** Person inside house indicates comfort. Adjust value to suit using + & -. Press OK to accept.

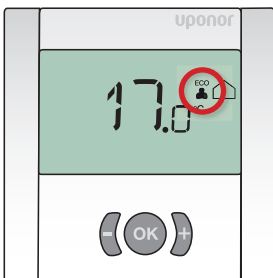

**28.** Person outside the house indicates ECO. Adjust value and press OK to accept.

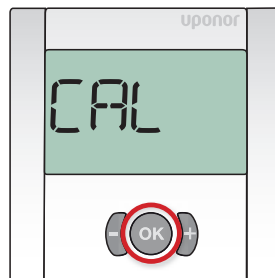

**29.** Press and hold OK to exit back to main screen.

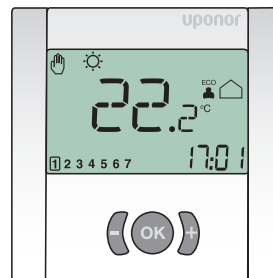

**30. Setting forced ECO or comfort mode.**  
To set the system in forced ECO or comfort mode:  
1. Press the OK button. The house icon starts flashing.  
2. Press the + or - button to change mode.  
3. Press the OK button. The screen returns to run mode displaying the selected mode and override icon.

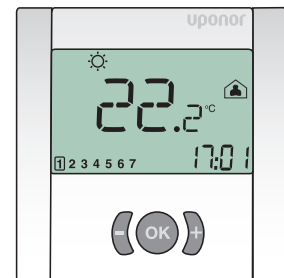

To remove forced mode:  
1. Press and hold OK for 3 seconds. The manual override icon disappears and the system returns to its original programmed mode.

**N.B.** The forced mode will stay in place until it has been cancelled. The next scheduled Eco or comfort event will not take it out of forced mode.

Please see chapter 9 of the installation and operation manual for further detailed information on programming and operating the wireless zone interface.

## Wired Zone Timer



1. Start up screen.

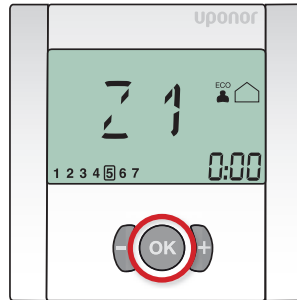

2. **Display screen.** Press and hold OK until screen 3 appears.

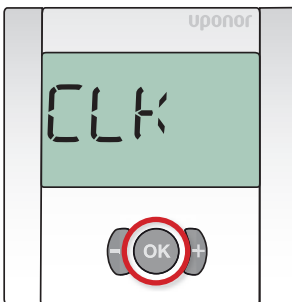

3. Press OK to enter clock menu.

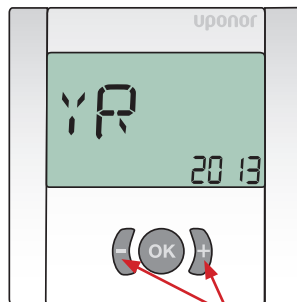

4. Adjust year using + or - , confirm by pressing OK.

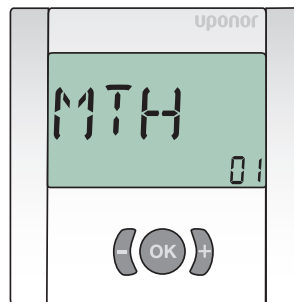

5. Select month 01 = Jan, confirm by pressing OK.

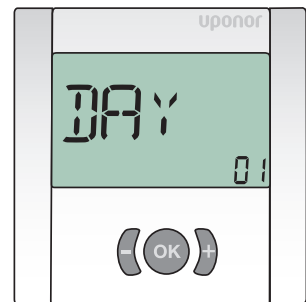

6. Select day of the month.



7. Choose between 24hr or 12hr time clock, confirm by pressing OK.



8. Adjust to correct time confirm by pressing OK.

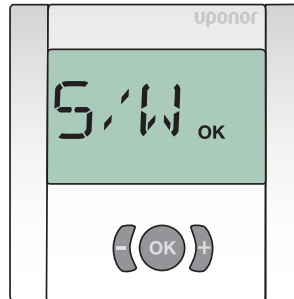

9. Confirm automatic summer winter time, change by pressing OK.



10. Enter programming menu by pressing OK.

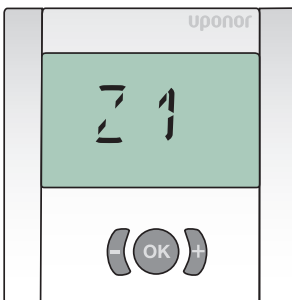

11. Enter Zone 1 schedule by pressing OK.

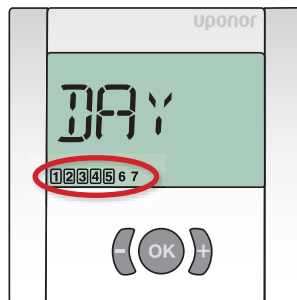

12. Select schedule group. Press + or - successively to select the group of days. There are three alternatives:  
 • 1 2 3 4 5 6 7 Monday till Friday, default setting.  
 • 1 2 3 4 5 6 7 Monday till Saturday.  
 • 1 2 3 4 5 6 7 Monday till Sunday.



13. To accept the default setting press and hold the OK button for 3 seconds. Repeat for Z2 and subsequent group day(s) if applicable.

Default Schedule Mon - Fri:  
 05:00 – 08:00 Comfort  
 08:00 – 17:00 Eco  
 17:00 – 22:00 Comfort  
 22:00 – 05:00 Eco  
 Default Schedule Sat –Sun:  
 06:00 – 23:00 Comfort  
 23:00 – 06:00 Eco



**14.** For user defined ECO and Comfort schedule please follow screen steps 14 - 21. Press the + button until you reach the desired time for comfort operation.



**15.** Example shows 6am as the chosen comfort event - press OK to put the person inside the house (this symbolises comfort mode).

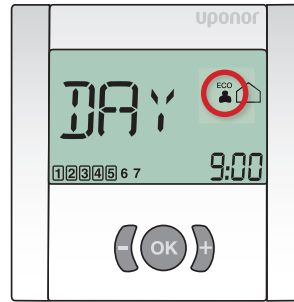

**16.** Example shows 9am as the next chosen ECO event. Press OK to take the person outside the house.

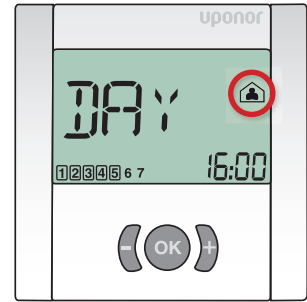

**17.** Example shows 4pm as the next comfort event. Press OK to put the person back inside the house.



**18.** Example shows 10pm as the next ECO event. Press OK to put the person outside the house.



**19.** Press the + button until 23:59. Leave until screen 19 appears.

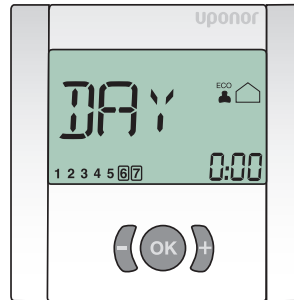

**20.** Repeat process for days 6 & 7.

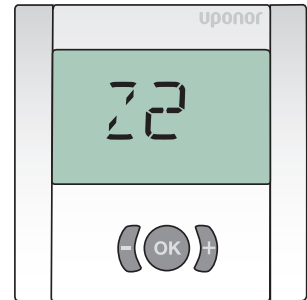

**21.** Press OK to enter Z2. Even if you are not using a second time schedule you still need to enter a program for Z2. For more info see page 12 of Wired System installation and operation manual.



**22.** To exit press and hold OK until the main screen appears.

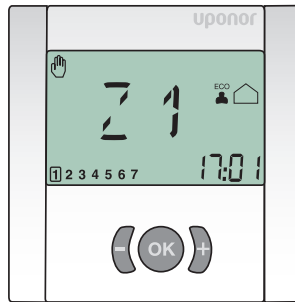

**23. Setting forced ECO or comfort mode**  
To set the system in forced ECO or comfort mode:  
1. Press the **OK** button.  
The house icon starts flashing.  
2. Press the + or - button to change from comfort to ECO mode or the other way around.  
3. Press the **OK** button.  
The screen returns to run mode displaying the selected ECO or comfort mode and the manual override icon 

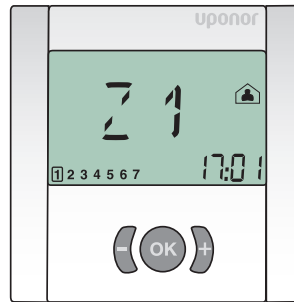

To remove forced mode:  
1. Press and hold **OK** for 3 seconds.  
The manual override icon  disappears and the system returns to its original programmed mode.  
  
N.B. The forced mode will stay in place until it has been cancelled. The next scheduled Eco or comfort event will not take it out of forced mode.

Please see chapter 9 of the installation and operation manual for further detailed information on programming and operating the wireless zone interface.

For more help on operating the Wired Zone Timer visit us at:  
[http://uponoruk.mobi/i-36\\_modes\\_236.php](http://uponoruk.mobi/i-36_modes_236.php)

## Wired Digital Thermostat



1. Start up screen.

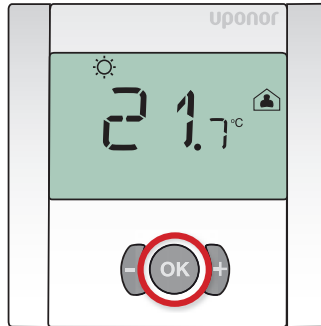

2. Main display screen. Press and hold OK button until screen 3 appears.

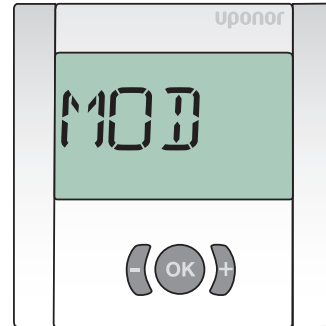

3. Enter mode menu by pressing OK.

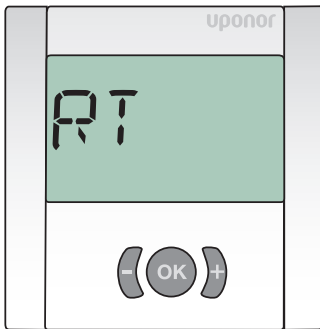

4. Select RT for room thermostat only. Press OK to confirm.  
RFT - Air sensor + floor sensor.  
RS - Floor sensor only

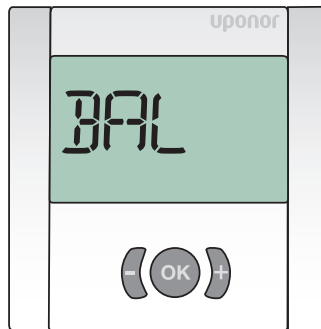

5. Select balance mode by pressing OK.

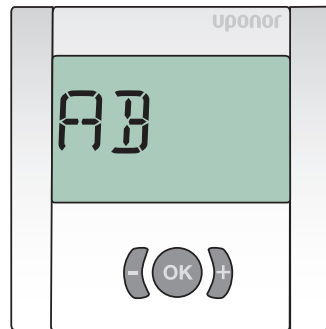

6. Adjust to AB (auto balance) and press OK



7. Select ECO menu by pressing OK.

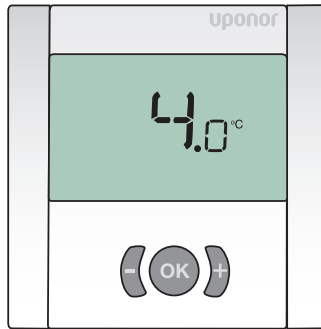

8. Adjust ECO reduction to 4°C. Recommended by Uponor.

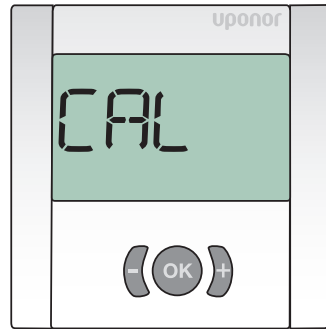

9. Press and hold OK to exit to main display.

Please see chapter 9 of the wired manual for more detailed information on thermostat settings.  
Alternatively please visit [www.uponoruk.mobi](http://www.uponoruk.mobi)

## 230V Digital Programmable Thermostat

### Time & Temperature Schedule

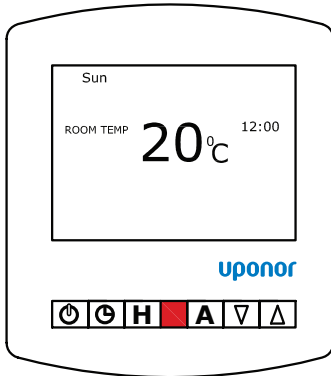

1. Default screen.

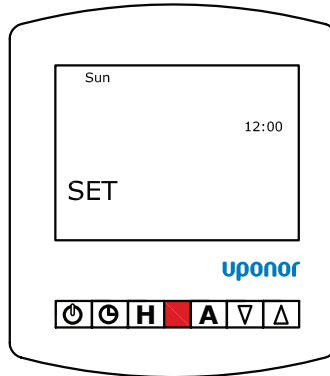

2. Press twice.  
Use to adjust time.  
Press **H** to accept.  
Use to adjust the day of the week.  
Press **A** to exit.

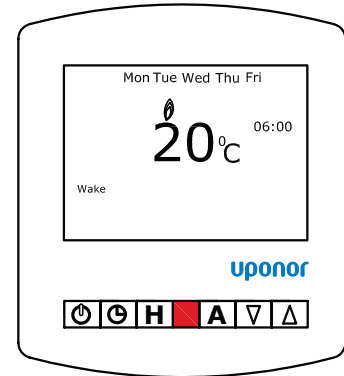

3. Press once.  
Use to adjust wake time.  
Press **H** to accept.  
Use to adjust temperature.  
Press **H** to accept.

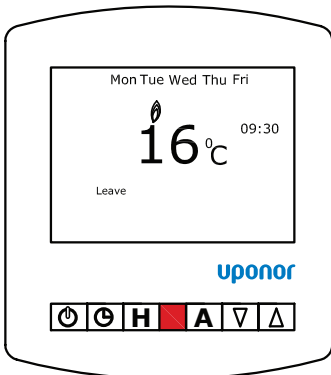

4. Press to adjust leave time.  
Press **H** to accept.  
Use to adjust temperature.  
Press **H** to accept.

**N.B.** Uponor recommend reducing the unoccupied temperature by 4°C.

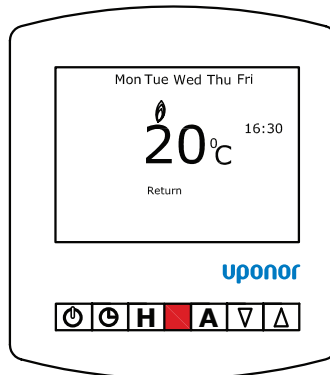

5. Use to adjust return time.  
Press **H** to accept.  
Use to adjust temperature.  
Press **H** to accept.

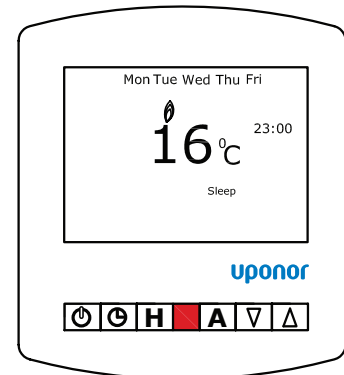

6. Use to adjust sleep time.  
Press **H** to accept.  
Use to adjust temperature.  
Press **H** to accept.

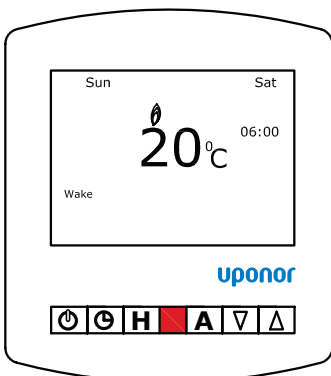

7. Repeat 3-6 for weekend time and temperature schedule.  
Press **A** at end of sequence to store and exit.



## 230V Digital Programmable Thermostat

### Floor Temperature

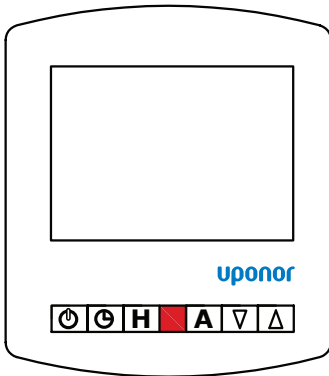

1. Press and hold **Power** to switch off.

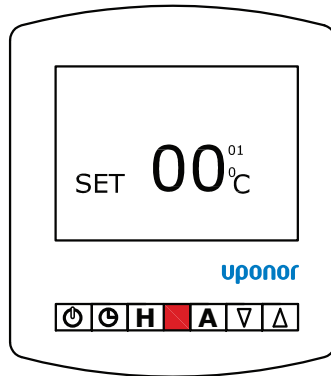

2. Press and hold **Mode** until showing as above.

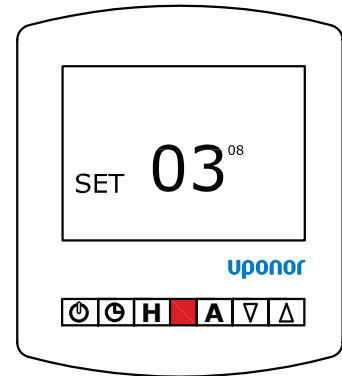

3. Select function 08 by pressing **Mode**.  
Use **Down Arrow** to select sensor mode.  
00 - built in air sensor only.  
01 - remote air sensor only.  
02 - floor sensor only.  
03 - floor sensor and built in air sensor.  
04 - floor and remote air sensor.

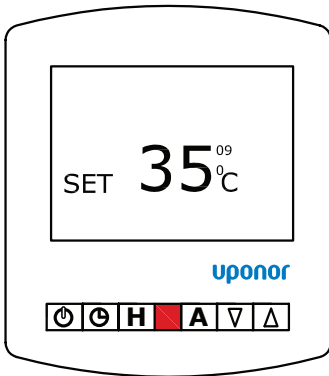

4. Select function 09 by pressing **Mode**.  
Use **Down Arrow** to adjust floor temperature.  
Press **A** to store and exit.  
Press **Power** to return to main screen.

### Additional Information

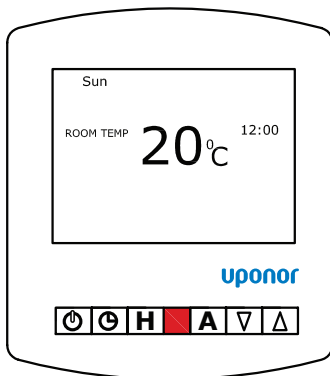

1. Press **Down Arrow** to adjust temperature.  
Press **A** to accept.  
Temperature is now set until the next scheduled change.

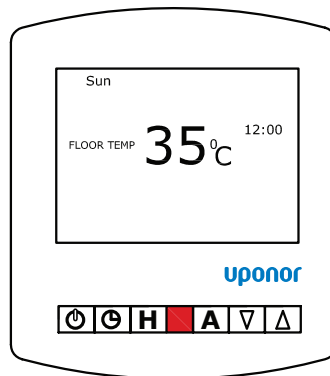

2. Press and hold **A** to view floor temperature. Floor temperature will display for 5 seconds.

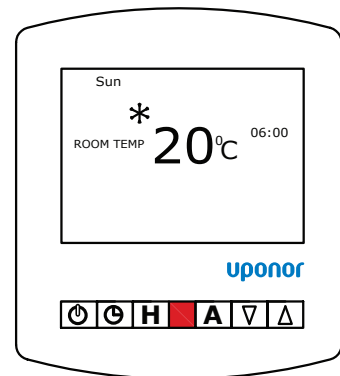

3. Press **Power** to enable frost protection.  
Press **Power** to disable frost protection.  
See page 14 of operating instructions for further details.

# Mechanical and Electrical Schematics



The following section is designed to show the installer how their system is to be wired and plumbed. The mechanical and electrical schematics apply to both MLCP and PEX systems.

• Water & Air Temperature Controls _____	64	• Climate Controller _____	76
• Uponor LS & TM Manifolds _____	74	• Single Zone Control with PUSH 12 _____	77
• Compact Control Pack & VPG Set _____	75	• Typical Pipe Layout _____	78

## Mechanical and Electrical Schematics

### Water Temperature Control:- V5 Compact Control Pack Air Temperature Control:- Wired Zone Controller (12V)

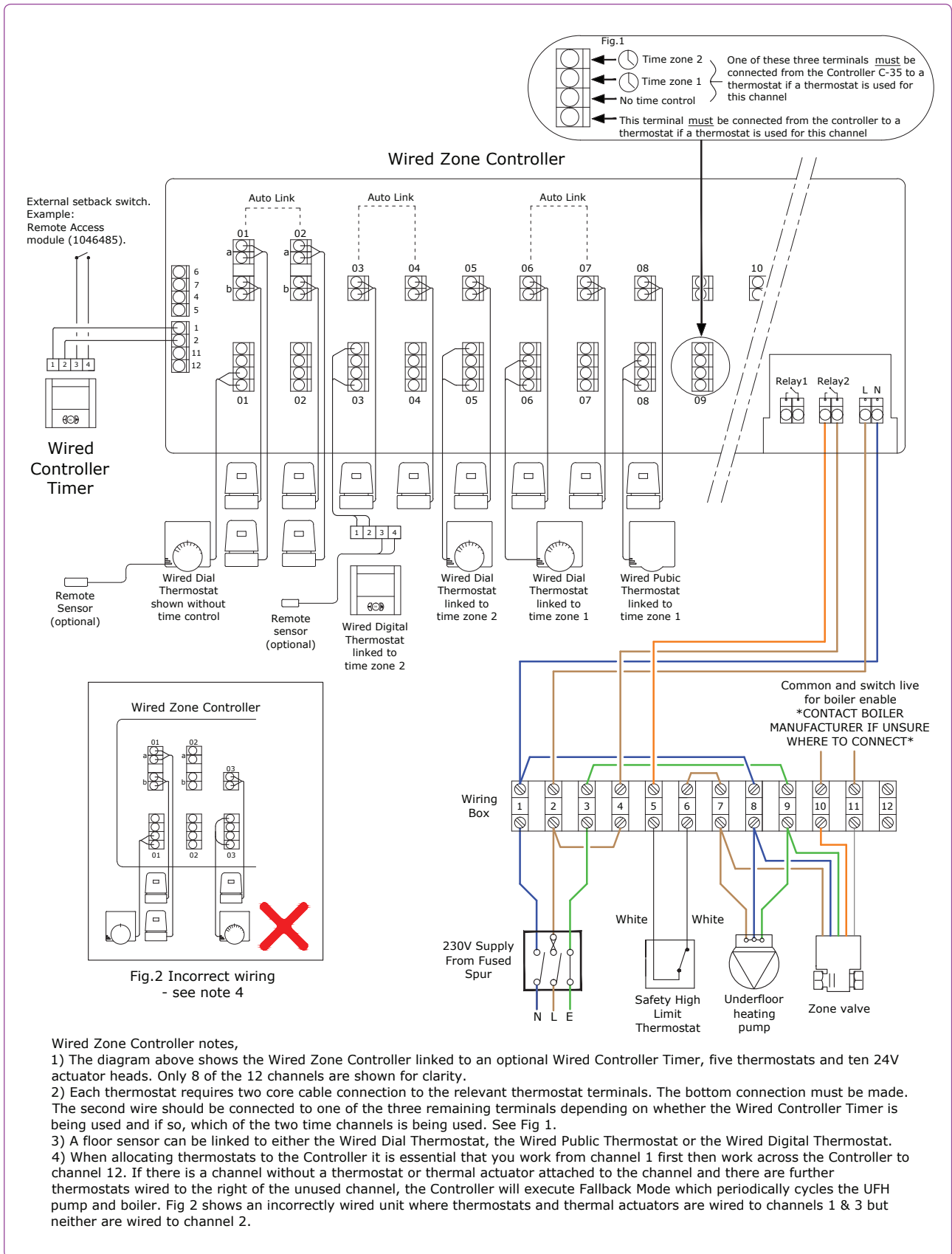

**Wired Zone Controller notes,**

- 1) The diagram above shows the Wired Zone Controller linked to an optional Wired Controller Timer, five thermostats and ten 24V actuator heads. Only 8 of the 12 channels are shown for clarity.
- 2) Each thermostat requires two core cable connection to the relevant thermostat terminals. The bottom connection must be made. The second wire should be connected to one of the three remaining terminals depending on whether the Wired Controller Timer is being used and if so, which of the two time channels is being used. See Fig 1.
- 3) A floor sensor can be linked to either the Wired Dial Thermostat, the Wired Public Thermostat or the Wired Digital Thermostat.
- 4) When allocating thermostats to the Controller it is essential that you work from channel 1 first then work across the Controller to channel 12. If there is a channel without a thermostat or thermal actuator attached to the channel and there are further thermostats wired to the right of the unused channel, the Controller will execute Fallback Mode which periodically cycles the UFH pump and boiler. Fig 2 shows an incorrectly wired unit where thermostats and thermal actuators are wired under channels 1 & 3 but neither are wired to channel 2.

## Water Temperature Control:- Climate Controller with 3 port valve/PPG-20/PPG-30. Air Temperature Control:- Wired Zone Controller (12V)

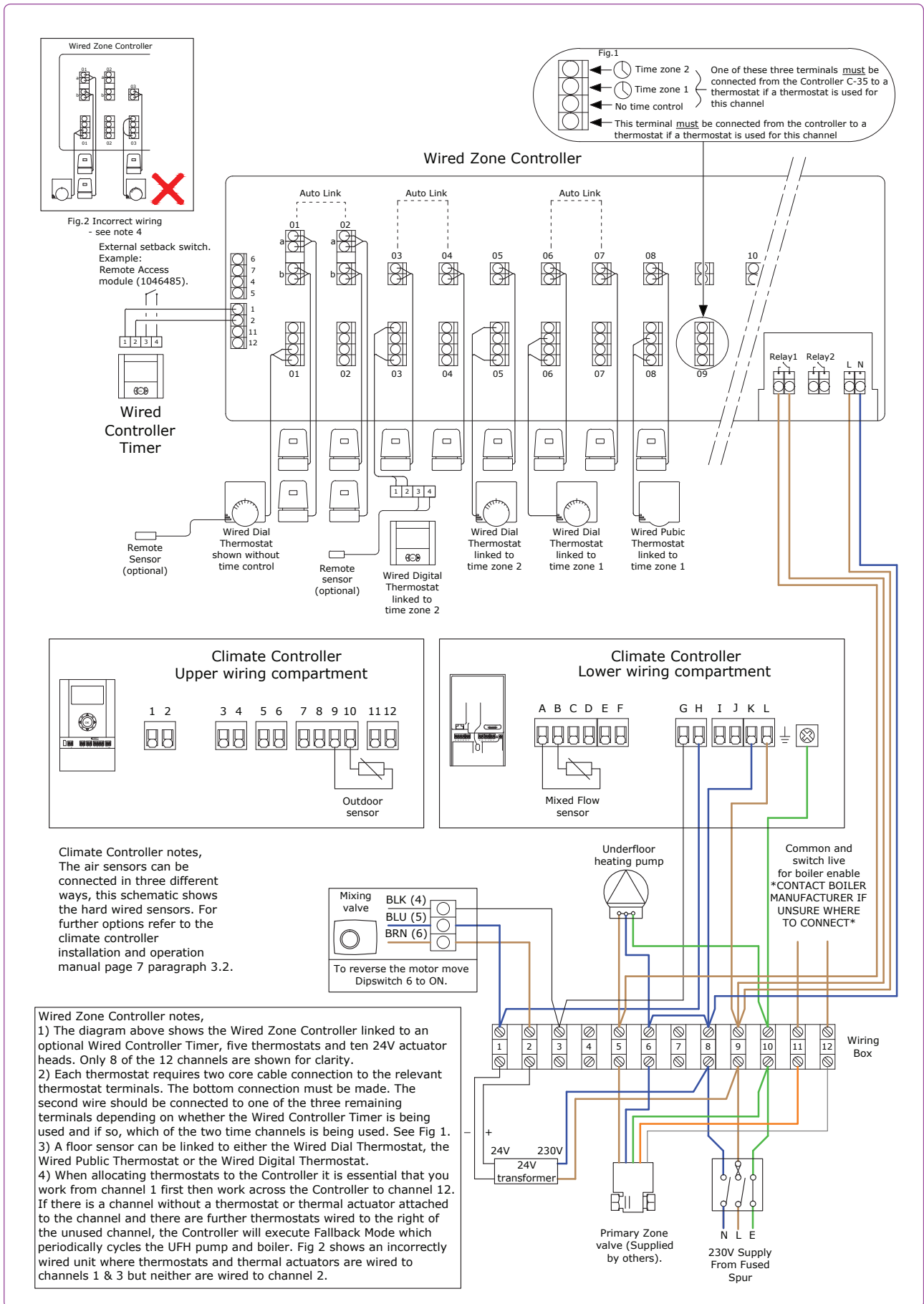

## Water Temperature Control:- VPG-10

## Air Temperature Control:- Wired Zone Controller with Actuator (12V)

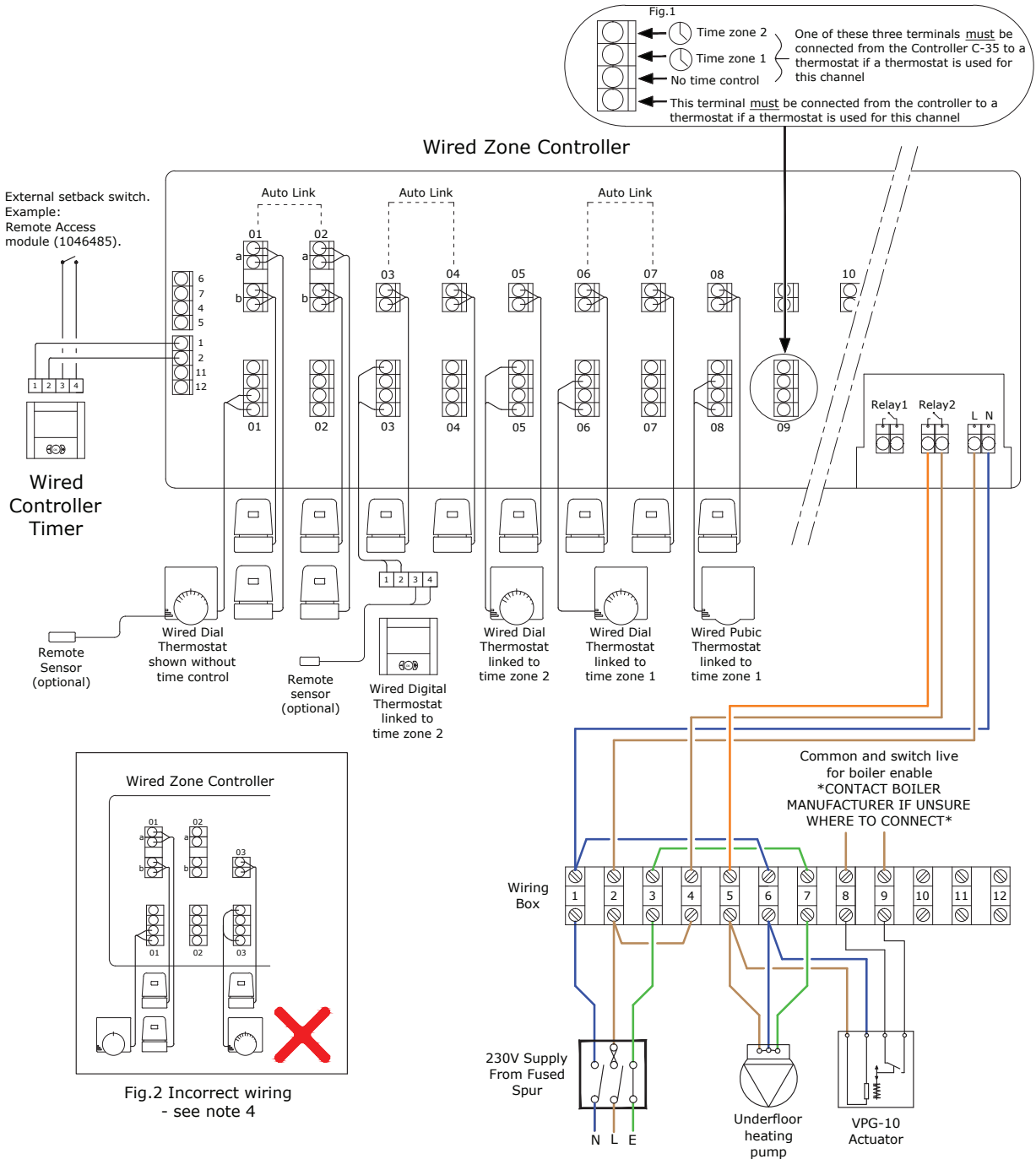

### Wired Zone Controller notes,

- 1) The diagram above shows the Wired Zone Controller linked to an optional Wired Controller Timer, five thermostats and ten 24V actuator heads. Only 8 of the 12 channels are shown for clarity.
- 2) Each thermostat requires two core cable connection to the relevant thermostat terminals. The bottom connection must be made. The second wire should be connected to one of the three remaining terminals depending on whether the Wired Controller Timer is being used and if so, which of the two time channels is being used. See Fig 1.
- 3) A floor sensor can be linked to either the Wired Dial Thermostat, the Wired Public Thermostat or the Wired Digital Thermostat.
- 4) When allocating thermostats to the Controller it is essential that you work from channel 1 first then work across the Controller to channel 12. If there is a channel without a thermostat or thermal actuator attached to the channel and there are further thermostats wired to the right of the unused channel, the Controller will execute Fallback Mode which periodically cycles the UFH pump and boiler. Fig 2 shows an incorrectly wired unit where thermostats and thermal actuators are wired to channels 1 & 3 but neither are wired to channel 2.



**Water Temperature Control:- V5 Compact Control Pack**  
**Air Temperature Control:- Wireless Zone Controller**

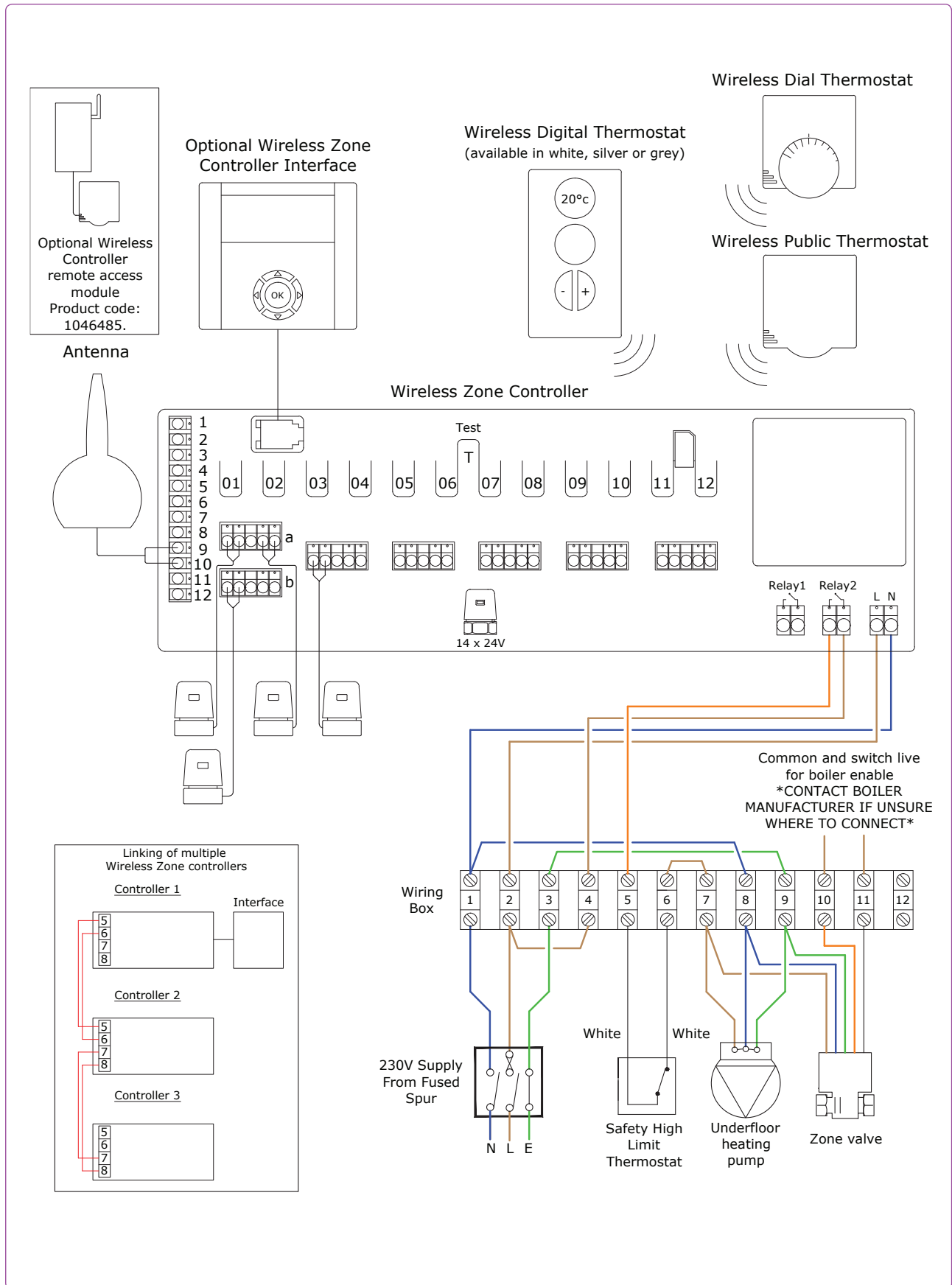

**Water Temperature Control:- Climate Controller with 3 port valve/PPG-20/PPG-30.**  
**Air Temperature Control:- Wireless Zone Controller**

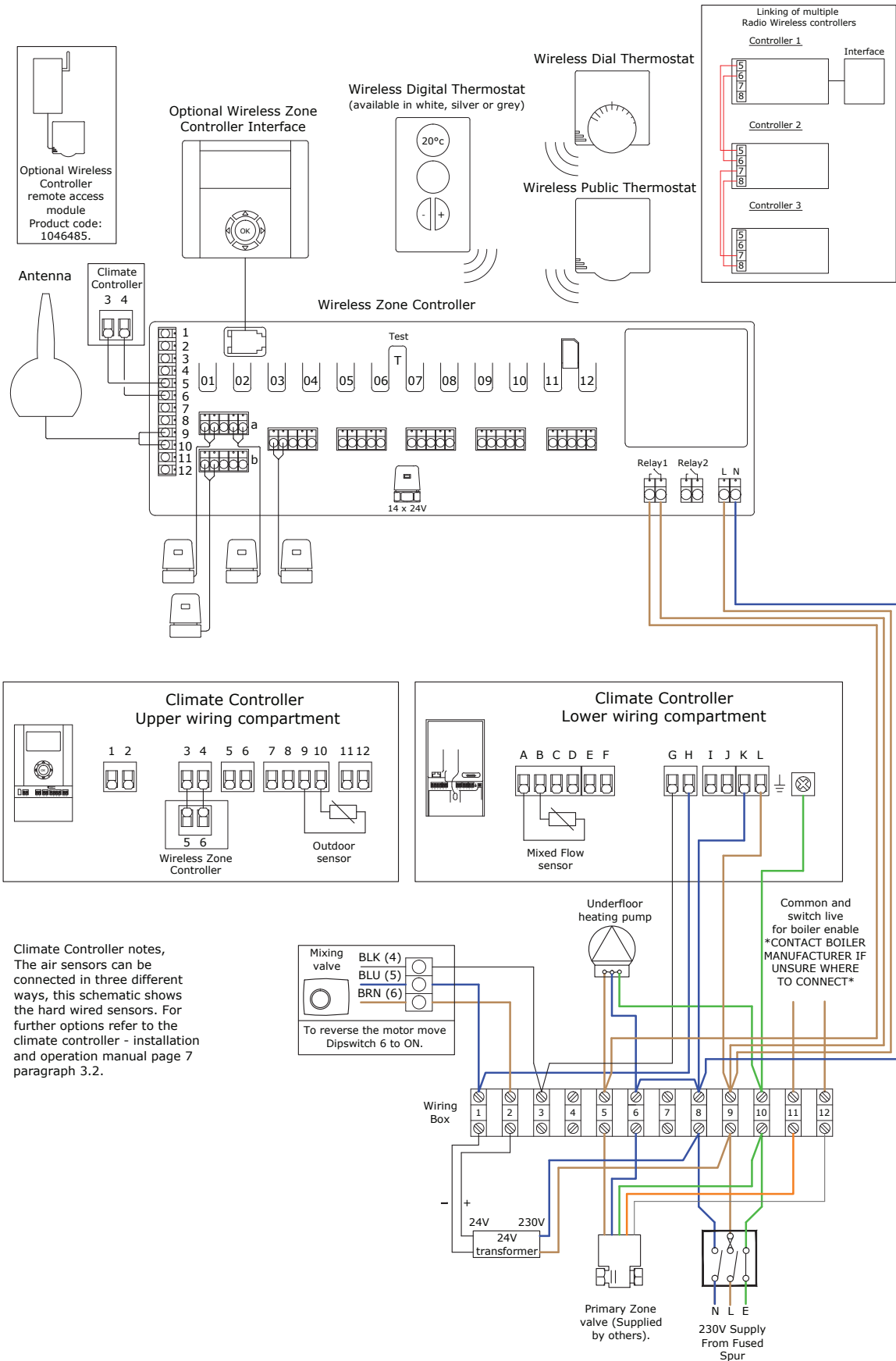

Climate Controller notes,  
The air sensors can be connected in three different ways, this schematic shows the hard wired sensors. For further options refer to the climate controller - installation and operation manual page 7 paragraph 3.2.

**Water Temperature Control:- VPG-10**  
**Air Temperature Control:- Wireless Zone Control with Actuator**

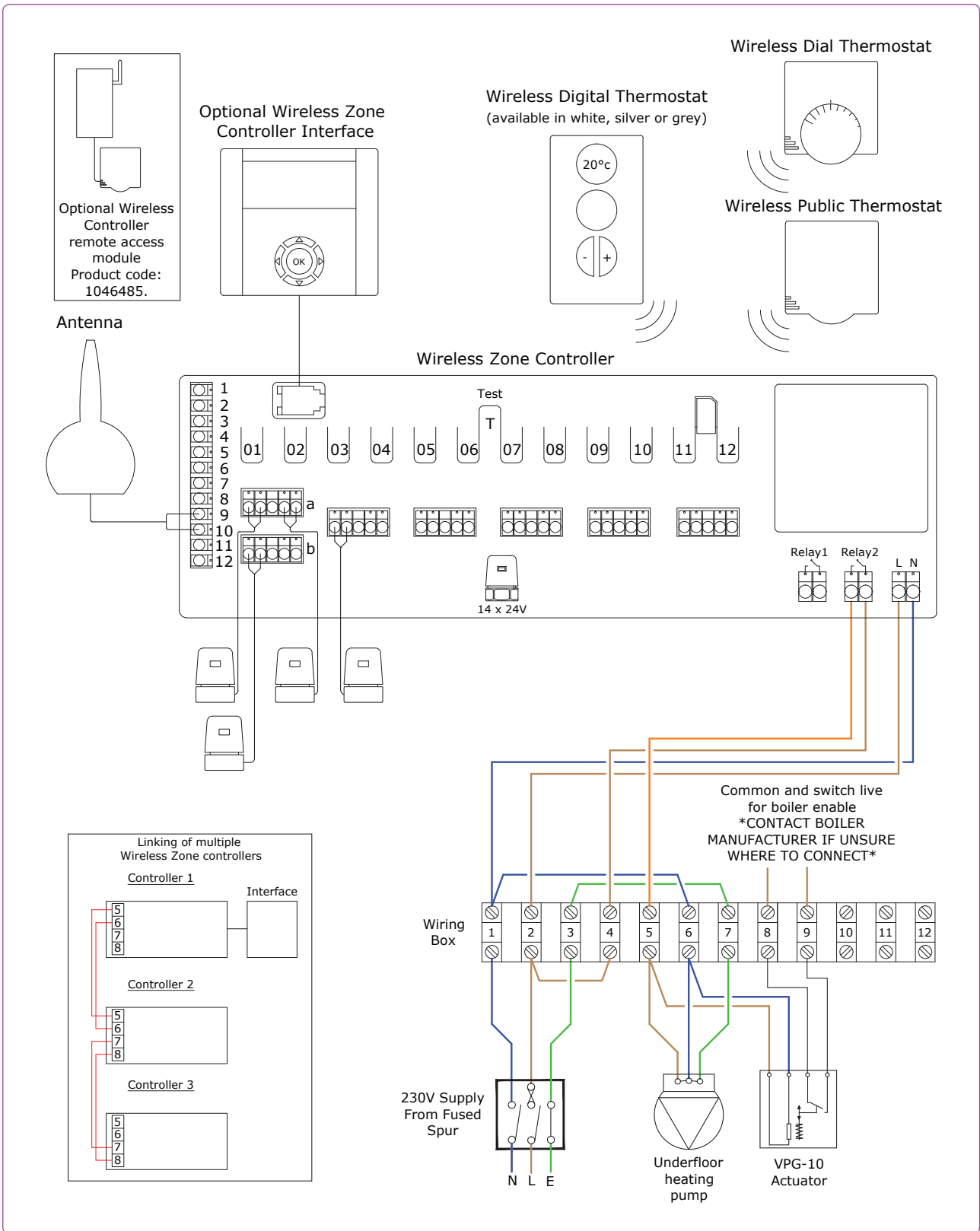

**Water Temperature Control:- Climate Controller with 3 port valve/PPG-20/PPG-30.  
Air Temperature Control:- Wired Zone Controller (230V)**

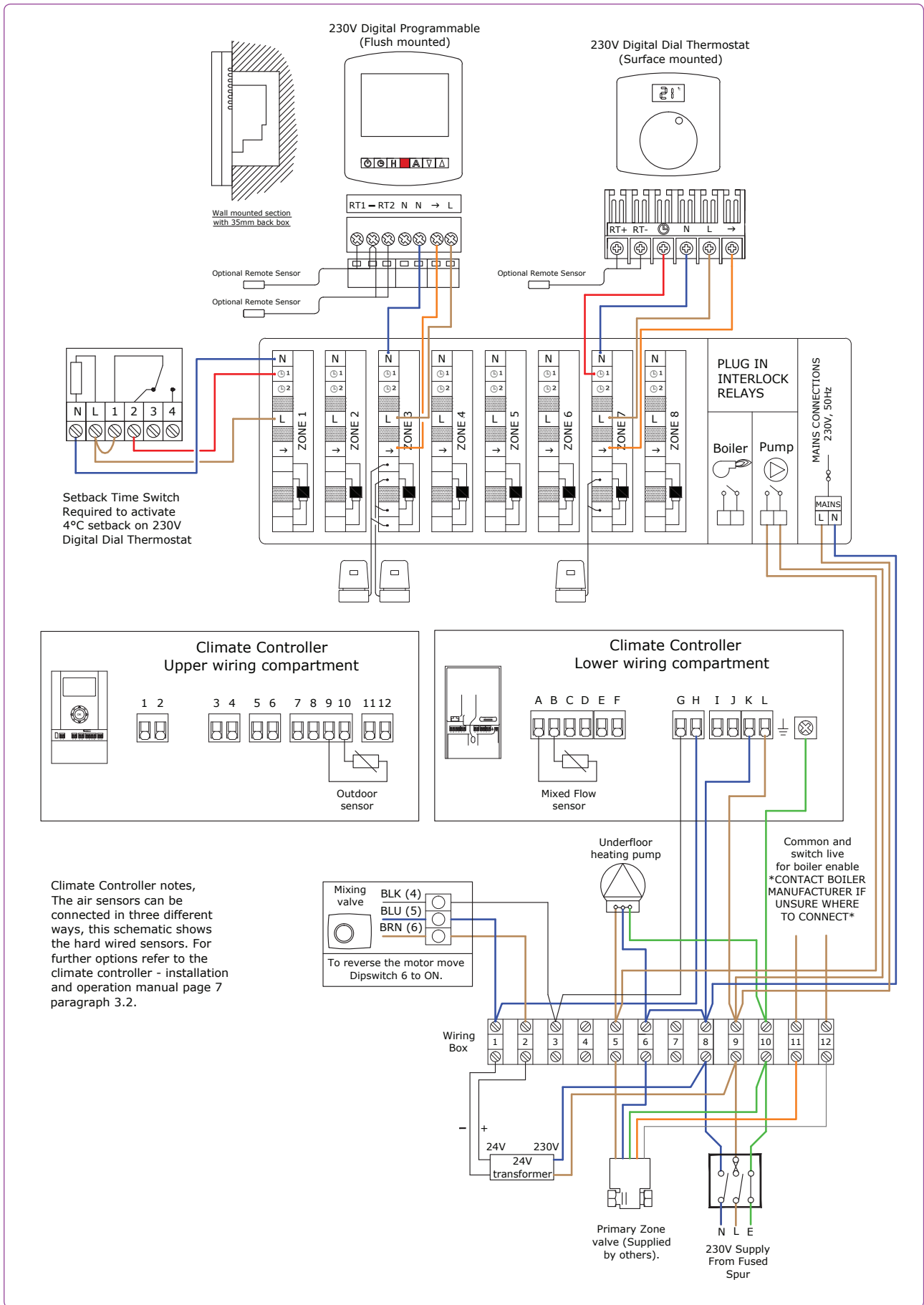

Climate Controller notes,  
The air sensors can be connected in three different ways, this schematic shows the hard wired sensors. For further options refer to the climate controller - installation and operation manual page 7 paragraph 3.2.

**Water Temperature Control:- V5 Compact Control Pack**  
**Air Temperature Control:- Wired Zone Controller (230V)**

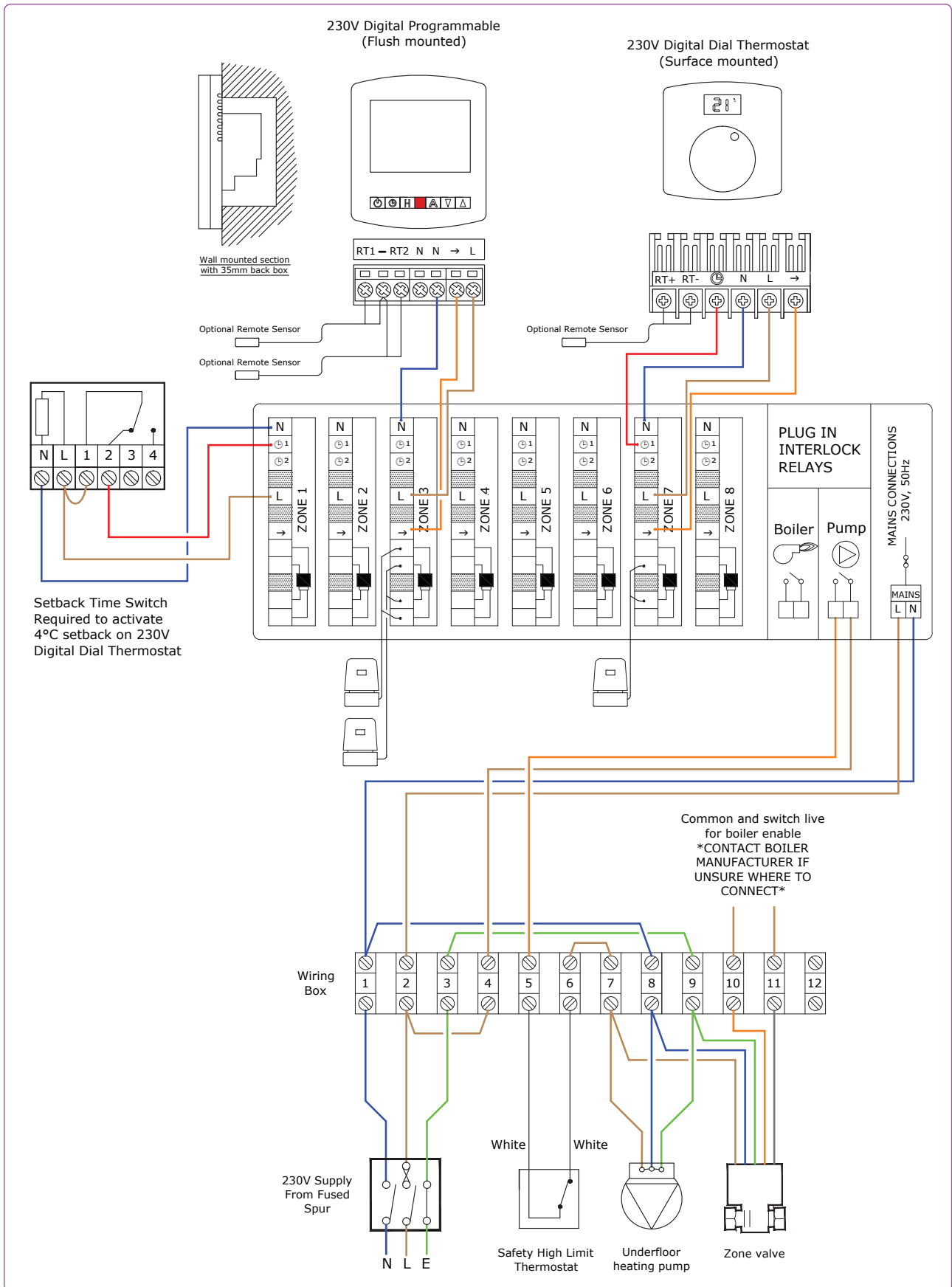



## Water Temperature Control:- VPG-10

## Air Temperature Control:- Wired Zone Controller with Actuator (230V)

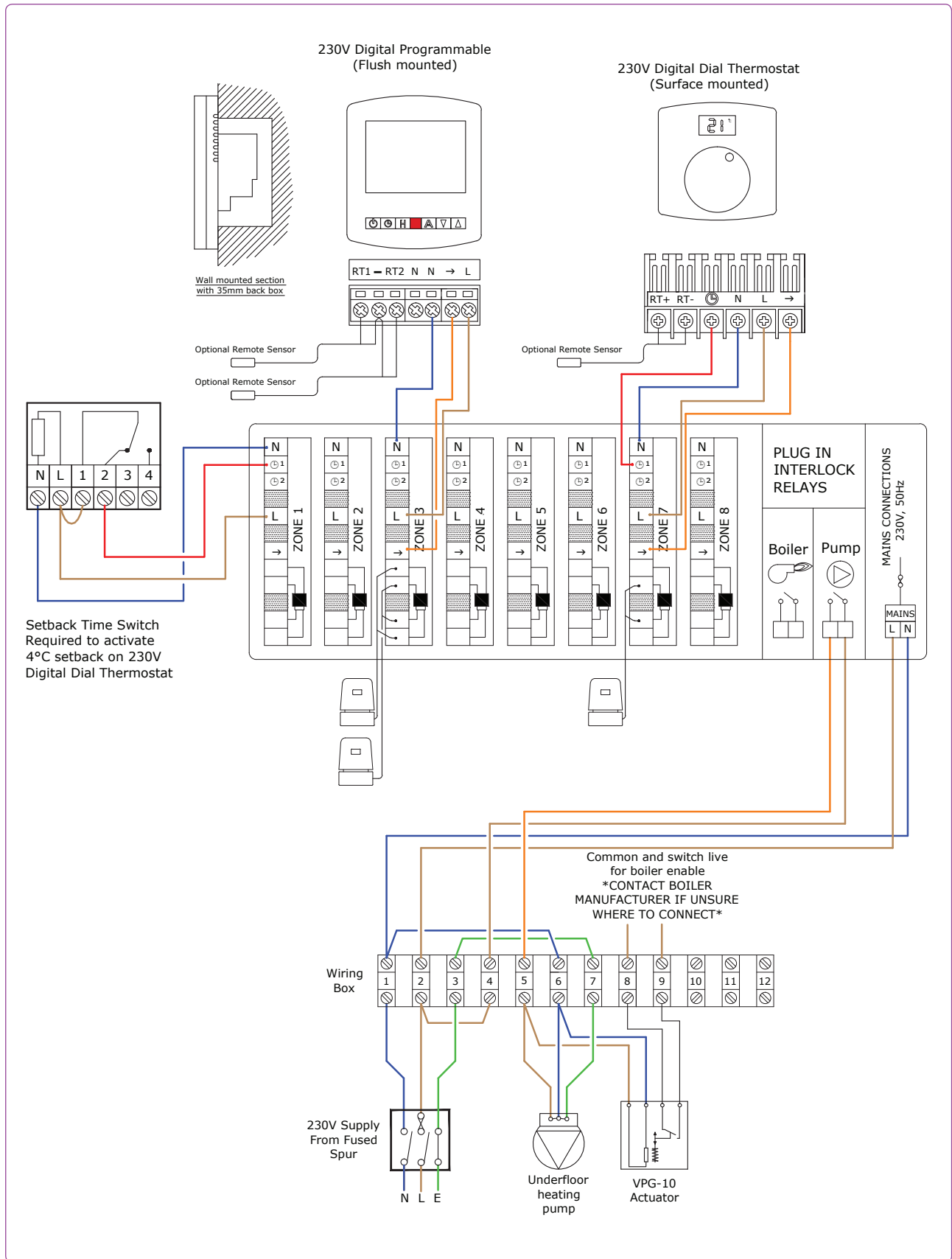

**Water Temperature Control:- V5 Compact Control Pack**  
**Air Temperature Control:- Hard Wired Single Zone**

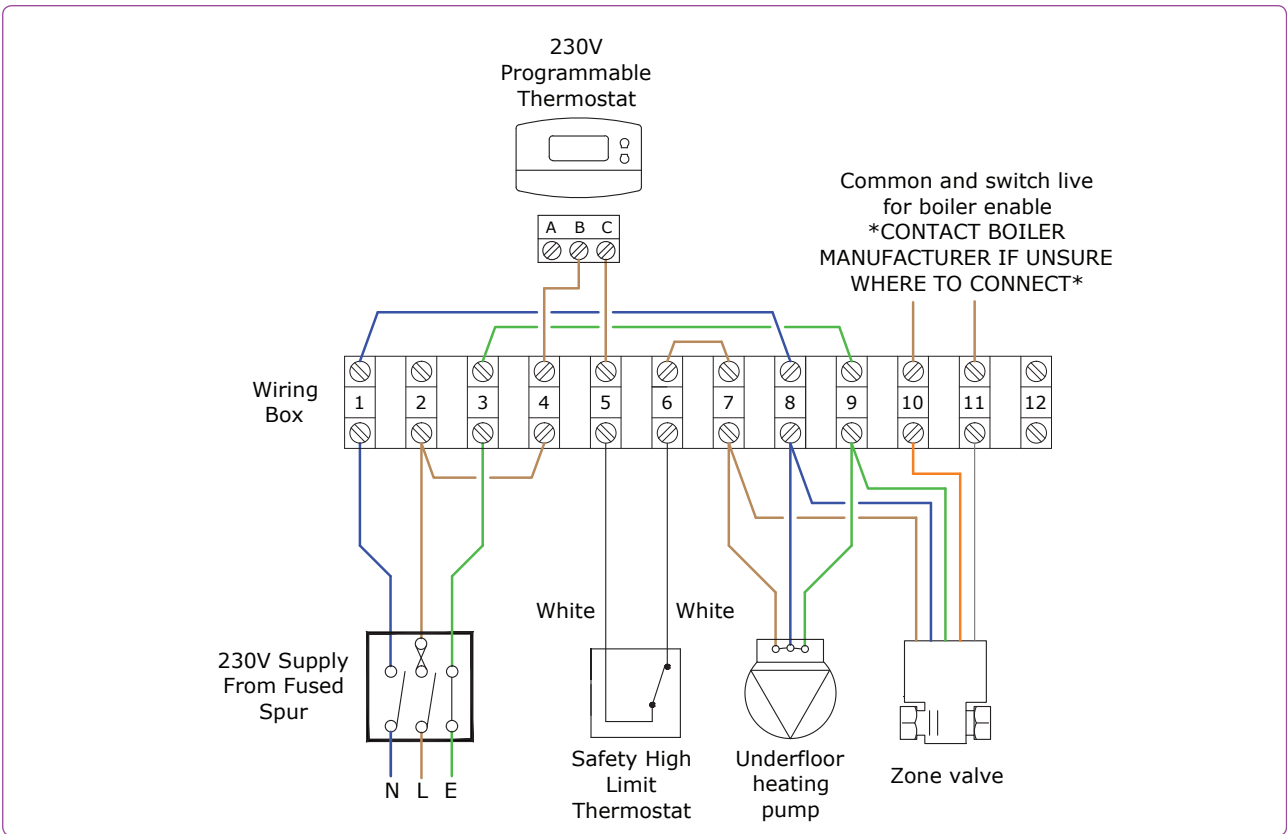

**Water Temperature Control:- VPG-10**  
**Air Temperature Control:- Hard Wired Single Zone with Actuator**

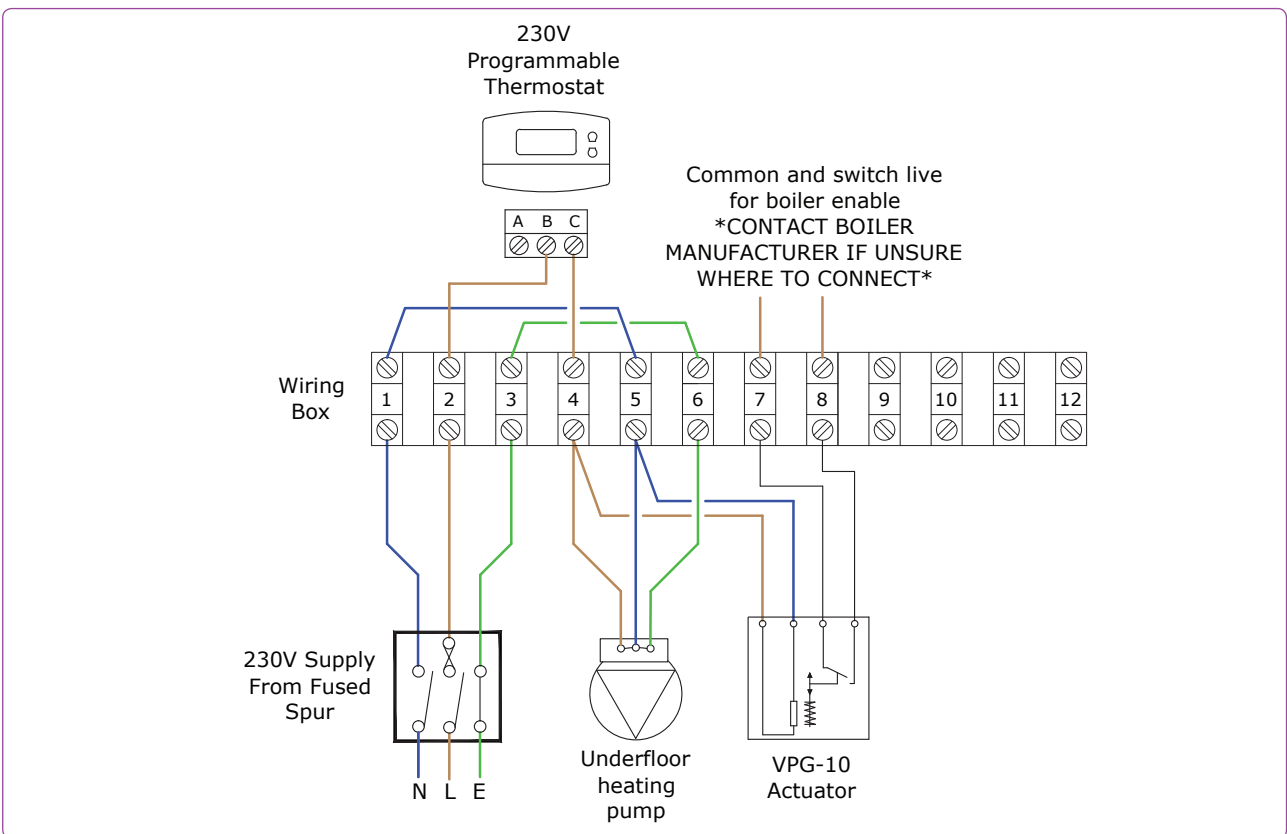

## Uponor LS Manifold, 2-12 Way

Manifold	Product Code	Length
2 Port	1002201	147mm
3 Port	1002202	197mm
4 Port	1002203	247mm
5 Port	1002204	297mm
6 Port	1002205	347mm
7 Port	1002206	397mm
8 Port	1002207	447mm
9 Port	1002208	497mm
10 Port	1002198	547mm
11 Port	1002199	597mm
12 Port	1002200	647mm

The height of the manifold is 340mm and needs to be mounted at least 300mm from the floor.

**Notes,**

- 1) A bypass is recommended on the primary circuit.
- 2) The drawing excludes pumps, heat source, isolating & regulating valves for clarity.
- 3) All items to be installed in accordance with manufacturer's instructions and current best practices.
- 4) If the ball valves are used (to be ordered separately) then the length will extend by 85mm.

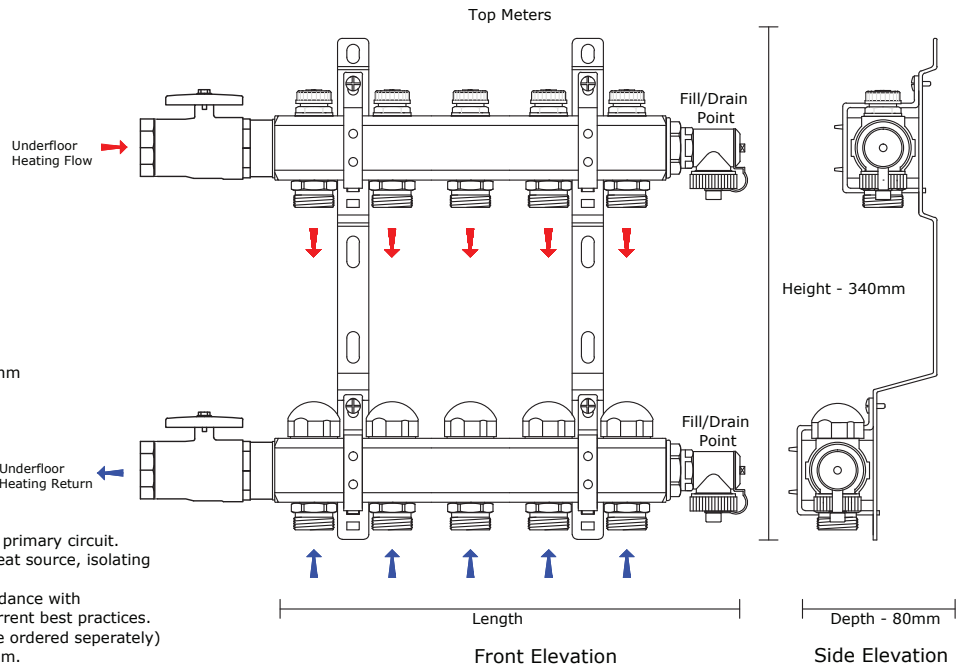

## Uponor TM Manifold, 2-12 Way

Manifold	Product Code	Length
2 Port	1002201	147mm
3 Port	1002202	197mm
4 Port	1002203	247mm
5 Port	1002204	297mm
6 Port	1002205	347mm
7 Port	1002206	397mm
8 Port	1002207	447mm
9 Port	1002208	497mm
10 Port	1002198	547mm
11 Port	1002199	597mm
12 Port	1002200	647mm

The height of the manifold is 340mm and needs to be mounted at least 300mm from the floor.

**Notes,**

- 1) A bypass is recommended on the primary circuit.
- 2) The drawing excludes pumps, heat source, isolating & regulating valves for clarity.
- 3) All items to be installed in accordance with manufacturer's instructions and current best practices.
- 4) If the ball valves are used (to be ordered separately) then the length will extend by 85mm.

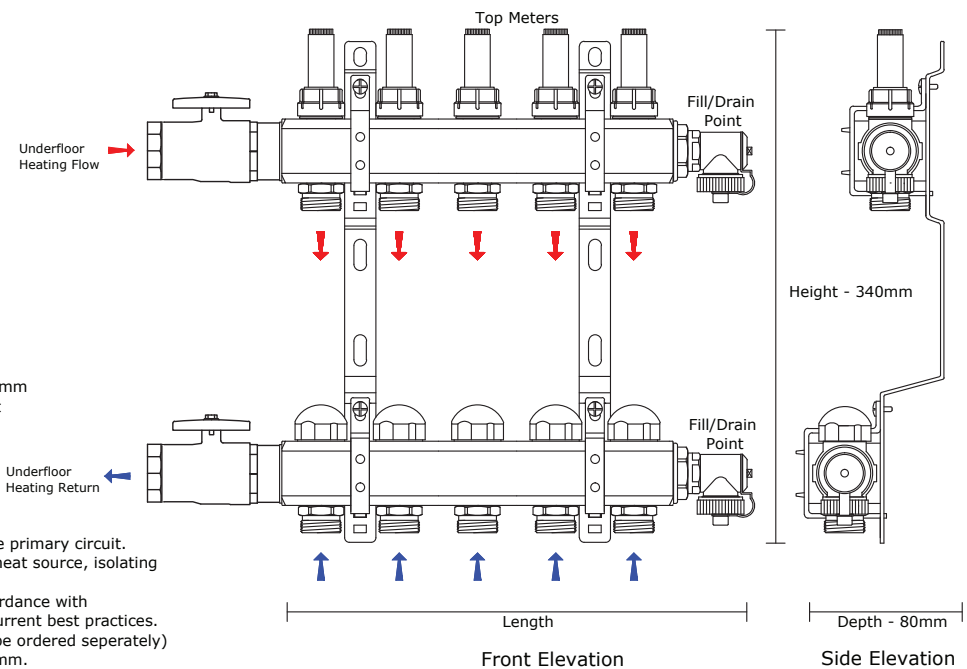

## V5 compact Control Pack

Manifold	Length
2 Port	340mm
3 Port	390mm
4 Port	440mm
5 Port	490mm
6 Port	540mm
7 Port	590mm
8 Port	640mm
9 Port	690mm
10 Port	740mm
11 Port	790mm
12 Port	840mm

The height of the compact control pack with manifold is 350mm and 135mm deep, the manifold also needs to be mounted at least 300mm from the floor.

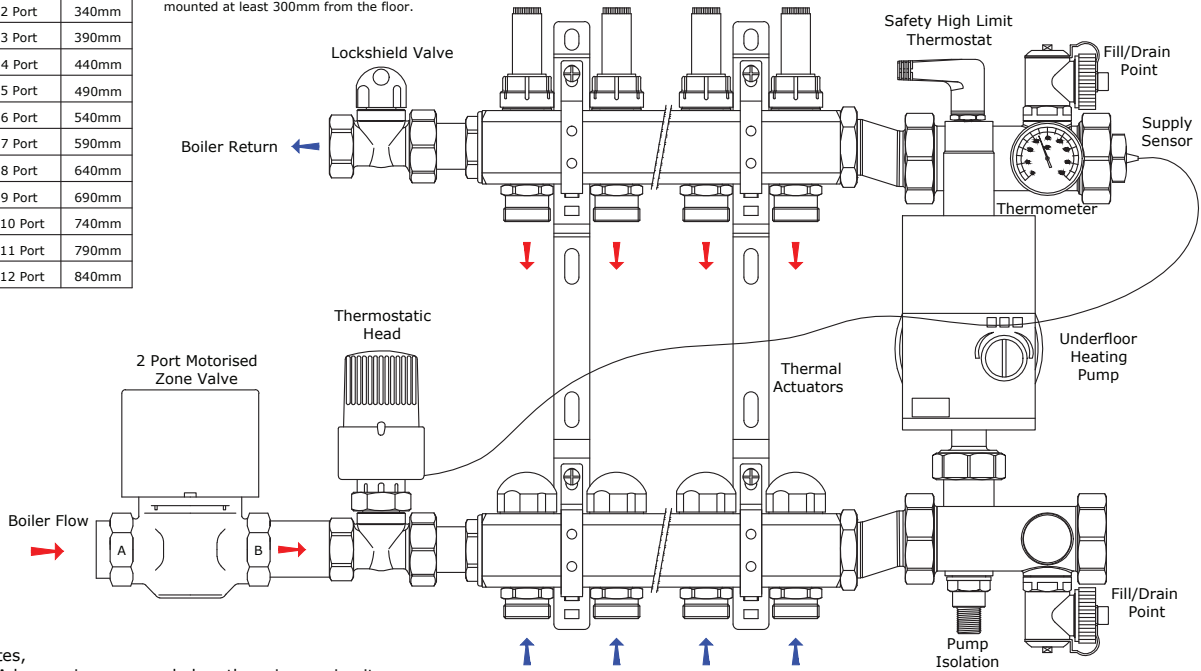

- Notes,
- 1) A bypass is recommended on the primary circuit.
  - 2) The drawing excludes isolating & regulating valves for clarity.
  - 3) All items to be installed in accordance with manufacturer's instructions and current best practices.

## VPG-10

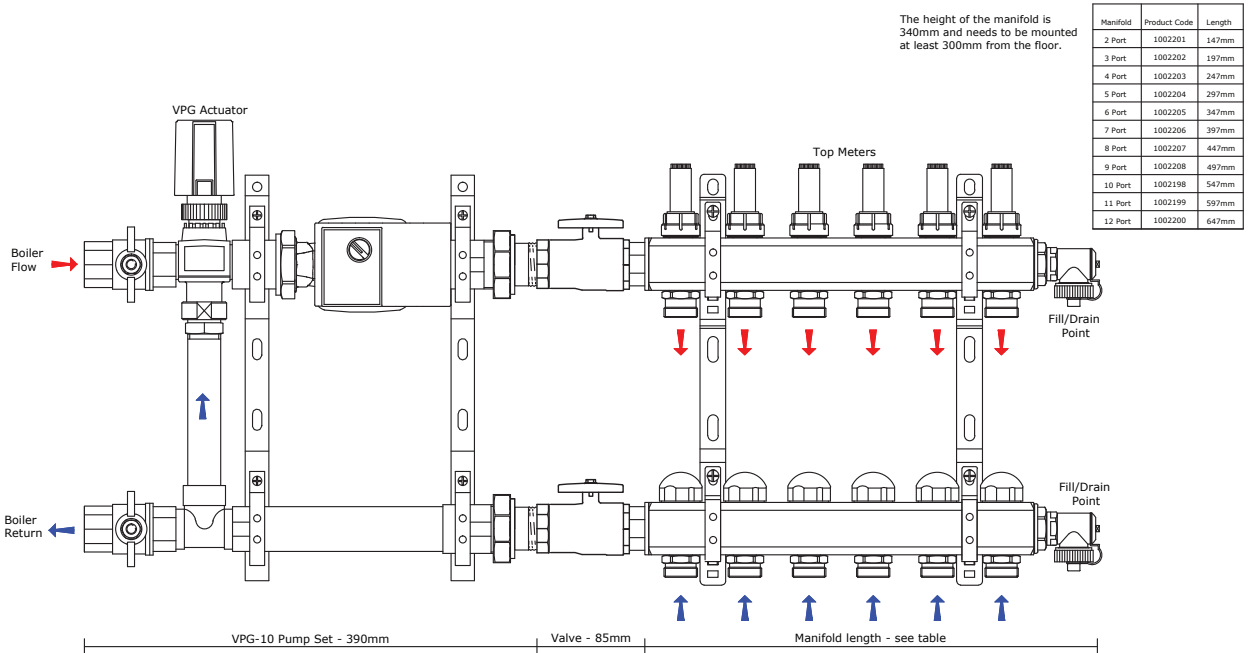

The height of the manifold is 340mm and needs to be mounted at least 300mm from the floor.

Manifold	Product Code	Length
2 Port	1002201	147mm
3 Port	1002202	197mm
4 Port	1002203	247mm
5 Port	1002204	297mm
6 Port	1002205	347mm
7 Port	1002206	397mm
8 Port	1002207	447mm
9 Port	1002208	497mm
10 Port	1002198	547mm
11 Port	1002199	597mm
12 Port	1002200	647mm

- Notes,
- 1) A bypass is recommended on the primary circuit.
  - 2) The drawing excludes isolating & regulating valves for clarity.
  - 3) All items to be installed in accordance with manufacturer's instructions and current best practices.
  - 4) If limited space is available the manifold and pump set may be split and installed in different locations to save space.

## Climate Controller & PPG-20

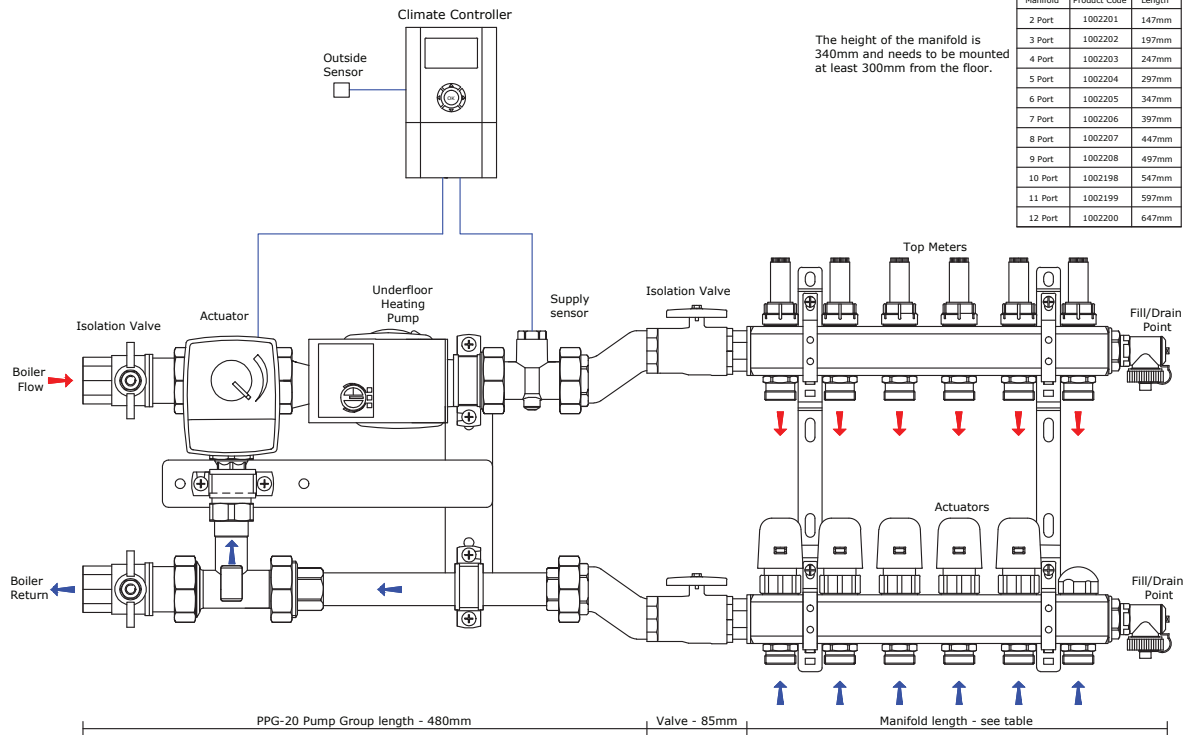

- Notes:
- 1) A bypass is recommended on the primary circuit.
  - 2) The drawing excludes isolating & regulating valves for clarity.
  - 3) All items to be installed in accordance with manufacturer's instructions and current best practices.
  - 4) If limited space is available the manifold and pump set may be split and installed in different locations to save space.

## 3 Port Valve & Climate Controller

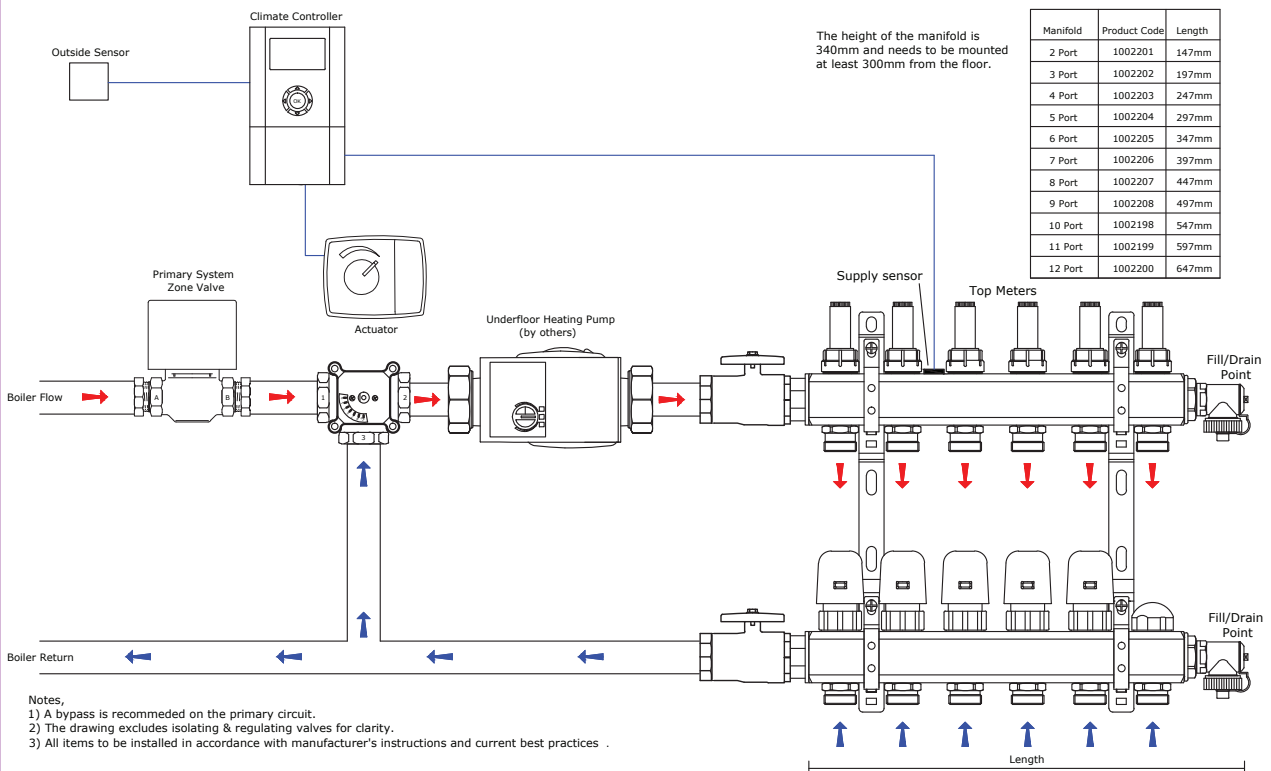

- Notes:
- 1) A bypass is recommended on the primary circuit.
  - 2) The drawing excludes isolating & regulating valves for clarity.
  - 3) All items to be installed in accordance with manufacturer's instructions and current best practices .



### Single Zone Control with PUSH 12 and electrical room control option

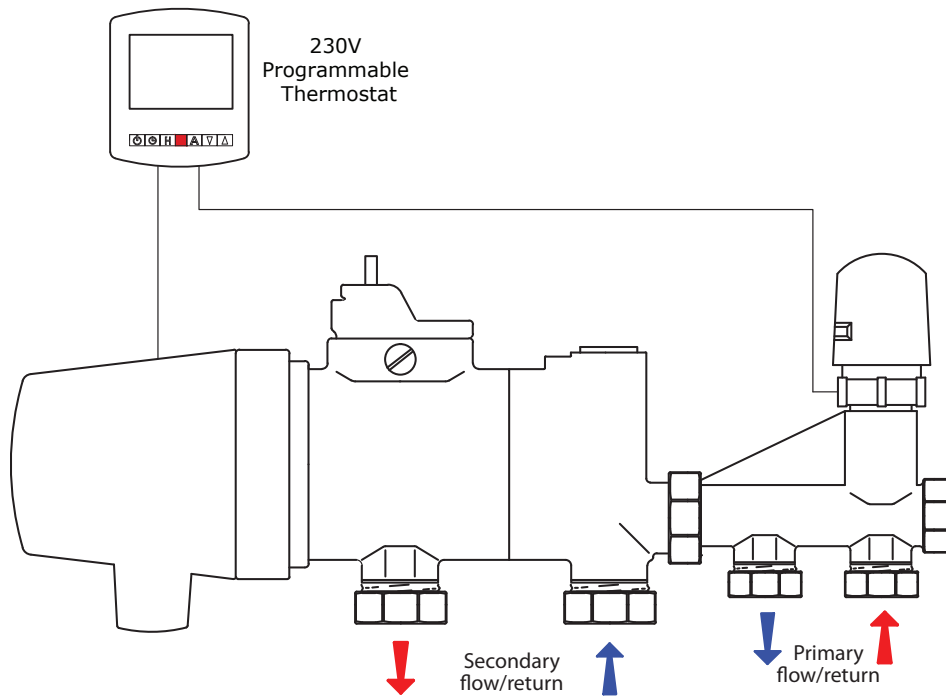

**Notes,**

- 1) The PUSH 12 unit is supplied as standard with a non-electric thermostatic head and 2m capillary connection to a remote room sensor. The drawing above shows the PUSH 12 fitted with an electro-thermal actuator for optional electrical room controls.
- 2) The UFH will be "ON" only when the radiator system is "ON" , i.e. controlled by the existing systems central heating programmer and room thermostat, unless a separate dedicated flow and return plus 2-port zone valve is installed to fire the boiler and boiler pump.

### PUSH 12 wiring details when fitted with optional electro-thermal actuator

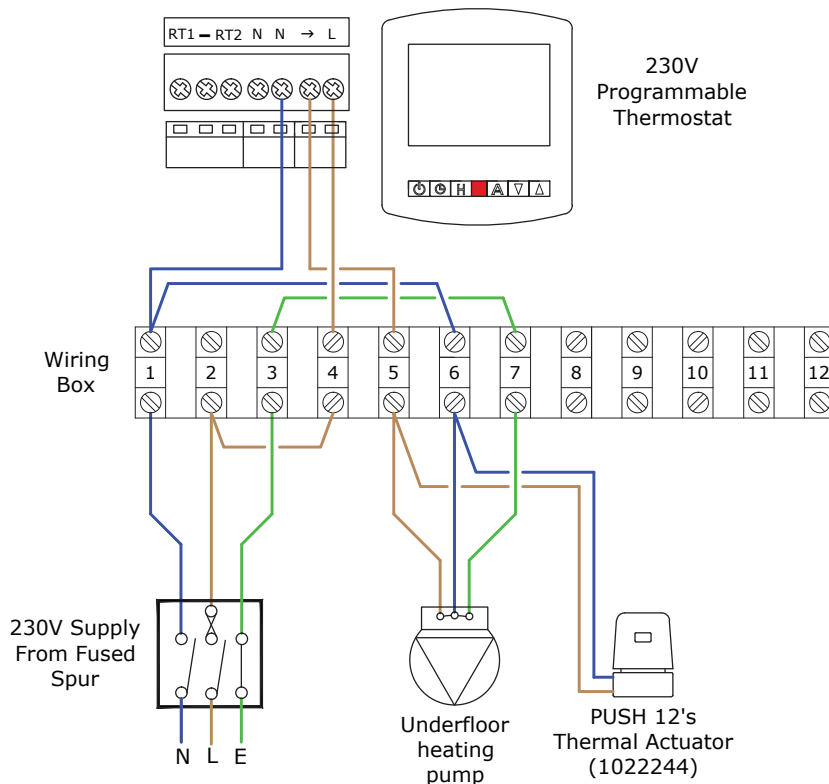

## Typical Pipe Layout

### Example for Solid Ground Floor in a small domestic property

Drawing showing 4 zones for independent temperature control and with UFH manifold centrally located beneath the stairs.

Drawing showing room thermostat locations.

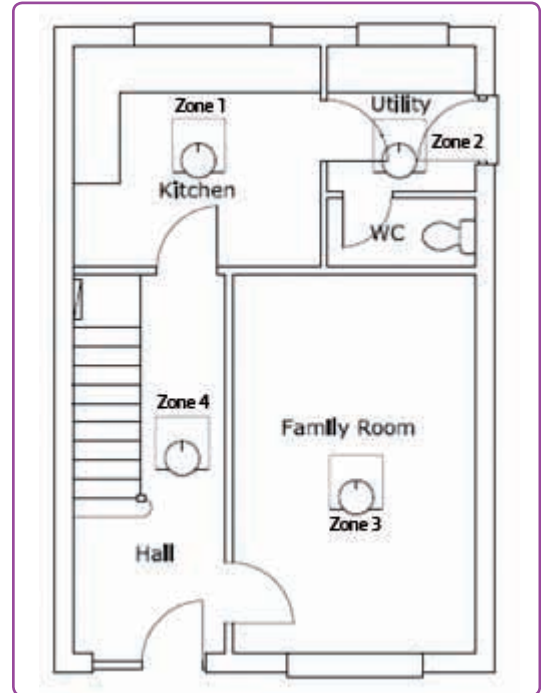
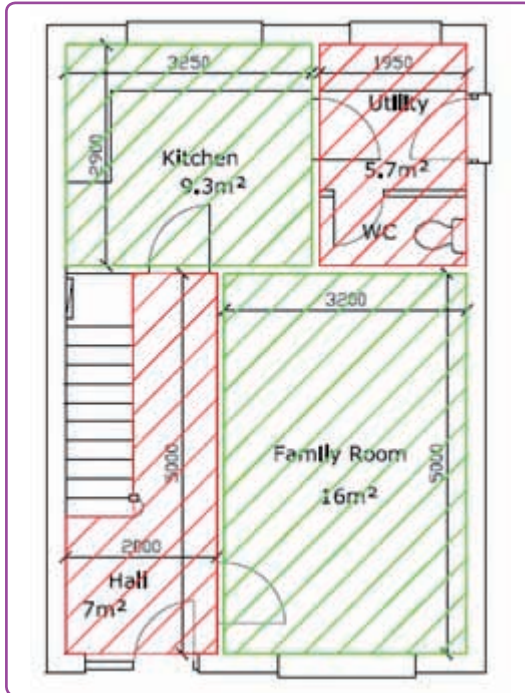

Drawing showing route of pipe tails from UFH manifold to each room.

Drawing showing completed pipe layout.

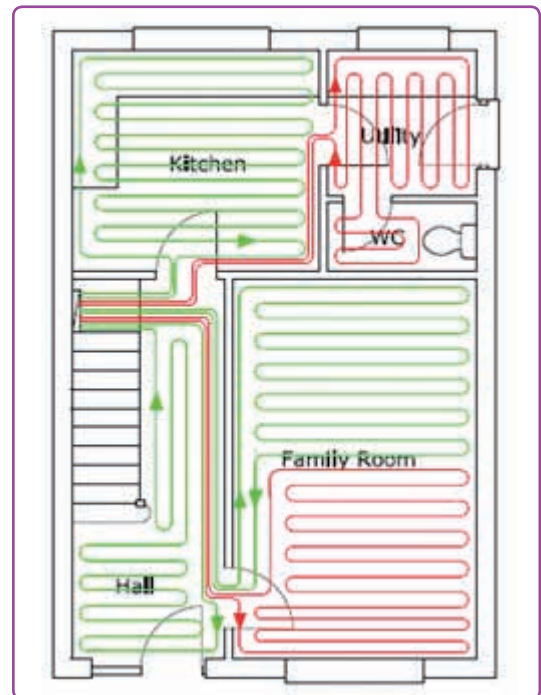
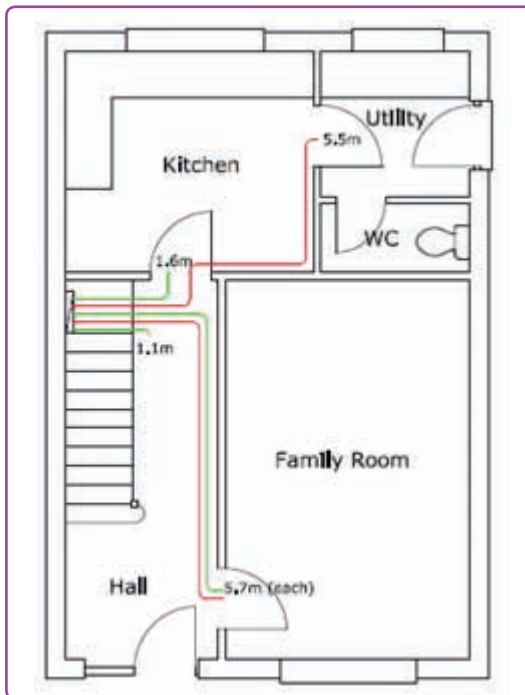

#### System details

Floor type:	Solid
Fixing Method:	Kombi Klips
Pipe size and type:	16mm MLCP
Pipe pitch:	200mm
Max heat output:	100 W/m <sup>2</sup>

#### Tabulated room details

Room or Zone (Number)	Room or Zone (Name)	Floor Area (m <sup>2</sup> )	Distance to manifold (m)	No. of Loops (Qty)	Pipe Required (m)	Selected Coil Length
1	Kitchen	9.3	1.6	1	52.7	1 x 75m
2	Utility/WC	5.7	5.5	1	42.5	1 x 50m
3	Family Room	16	5.7	2	108.8	1 x 50m 1 x 75m
4	Hall	7	1.1	1	40.2	1 x 50m

\* Please note that Uponor recommends laying UFH pipe underneath units.

# Heat Pumps



Uponor guidance on using heat pumps with an UFH system, and floor heat outputs for different UFH systems with various floor covering resistances.

- Heat Pump \_\_\_\_\_ 80
- UFH Outputs with Floor Coverings \_\_\_\_\_ 80

## Heat Pumps

Uponor will not normally supply water temperature controls when ground/air source heat pumps are employed. The heat pump's integral controls should be set at a water temperature that satisfies the requirements of the UFH system. If you are using a heat pump and we have quoted the water temperature controls, please omit them from our offer or contact our technical team for advice.

To ensure for adequate water flow around the UFH loops additional circulating pump(s) will normally be required. Circulating pump(s) should be located at the inlet (upstream) of the manifold(s) and to be supplied by others. Uponor will be pleased to give advice regarding pump duty.

A buffer vessel is often fitted between the heat pump and the UFH manifold(s), which provides for adequate water circulation through the heat pump at all times when it is running. This also allows for individual room controls to be fitted to each underfloor heated zone, because the primary flow (Heat Pump circuit) is hydraulically separated from the secondary flow (UFH circuits). If a buffer vessel is not incorporated within your system, then sufficient UFH loops should be uncontrolled (open circuit) to allow for adequate water flow rate through the heat pump to eliminate cycling.

Low mass UFH systems should only be used when heat requirements are so low as to allow operation well below the 50 – 55°C mean water temperature normally required. Such installations include plated systems for timber suspended and floating floors and void heating via the Unifoil system.

UFH with renewable energy heat generation should be designed to work on the lowest feasible water temperature to gain maximum energy saving benefits; heat pump coefficient of performance (COP) of 4 or more.

UFH will work with most types of floor coverings. However, it should be understood that coverings with relatively high thermal resistances will need to increase the UFH water temperature to offset building heat losses, and will result in lower COP and therefore higher running costs.

The tables that follow show floor heat outputs for different UFH systems with various floor covering resistances.

### Typical Maximum Heat Outputs at 40°C Mean Water Temperature:

#### 12mm PEX pipe (System 12)

Installation Type	Floor Heat Output (W/m <sup>2</sup> )
Timber Panels at c/c 175mm and 0.1 m <sup>2</sup> K/W floor covering thermal resistance	58
Floating Floor at c/c 125mm and 0.1 m <sup>2</sup> K/W combined resistance of floor deck and coverings	57
Timber Panels at c/c 175mm and 0.15 m <sup>2</sup> K/W floor covering thermal resistance	50
Floating Floor at c/c 125mm and 0.15 m <sup>2</sup> K/W combined resistance of floor deck and coverings	50

#### 16mm PEX or 16mm MLCP pipe

Installation Type	Floor Heat Output (W/m <sup>2</sup> )
Pipes embedded in screed at c/c 200mm. With low resistance floor covering, e.g. tiles	95
Pipes embedded in screed pipes at c/c 150mm and 0.1 m <sup>2</sup> K/W floor covering thermal resistance	67
Pipes embedded in screed pipes at c/c 200mm and 0.1 m <sup>2</sup> K/W floor covering thermal resistance	60
Plated system (timber or floating floors) at c/c 200mm with 18mm chipboard and 0.1 m <sup>2</sup> K/W floor covering thermal resistance	40
Unifoil system (timber suspended floors) with 18mm chipboard and 0.1 m <sup>2</sup> K/W floor covering thermal resistance	30

#### 20mm PEX pipe

Installation Type	Floor Heat Output (W/m <sup>2</sup> )
Solid floor at c/c 200mm. With low resistance floor covering, e.g. tiles	100
Solid floor at c/c 300mm. With low resistance floor covering, e.g. tiles	76
Solid floor at c/c 150mm and 0.1 m <sup>2</sup> K/W floor covering thermal resistance	70
Solid floor at c/c 200mm and 0.1 m <sup>2</sup> K/W floor covering thermal resistance	66
Solid floor at c/c 300mm and 0.1 m <sup>2</sup> K/W floor covering thermal resistance	54
Plated system (timber or floating floors) at c/c 200mm with 18mm chipboard and 0.1 m <sup>2</sup> K/W floor covering thermal resistance	46
Plated system (timber or floating floors) at c/c 300mm with 18mm chipboard and 0.1 m <sup>2</sup> K/W floor covering thermal resistance	38

Tables based upon:

- 1) 20°C Room Temperature
- 2) For solid floors output is based on 45mm screed depth above the pipe
- 3) Sufficient insulation to prevent downward losses exceeding 10% of heat input



# Filling, Venting and Pressure Testing



Filling, Venting and Pressure Testing

This section takes you through the required stages for filling, venting and pressure testing the system correctly.

- Filling the loops \_\_\_\_\_ 82
- Pressure testing \_\_\_\_\_ 83



## Filling and Venting the Loops



There are integral fill/vent valves together with hose connections as part of the manifold assembly. Hose unions are required for the 3/4" thread on the TM manifold.

With Compact Control Pack V5 fitted to TM/LS manifold the fill/vent valves would have been relocated to positions above and below the UFH pump.

Before starting, ensure that the fill port is uppermost, then:

- Ensure all electrical supplies are switched off.
  - Remove the fill port caps and washer and connect hose unions to both end caps.
  - The integral valves in both end caps must be opened to fill the system. Use the square key in the cap to open the fill port valves.
  - Ensure both isolating ball valves on the main flow and return pipes to the manifold are CLOSED. Alternatively, if a Compact Control Pack V5 is fitted close both control and lockshield valves. To close the control valve, firstly remove the thermostatic head and use one of the blue caps from a manifold loop to close the valve.
  - If using the V5 Compact Control Pack, fully close the valve on the elbow at the circulating pump inlet to ensure that water is forced around the UFH loops when filling and not short circuiting between the upper and lower manifold headers.
  - Close all underfloor heating loop flow and return valves on the manifold.
  - Fit a hose to the lower manifold hose union and run the other end of the hose to a suitable drain point.
  - Connect a hose to the upper manifold hose union and connect the other end of the hose to a mains water tap.
- Individual loops need to be purged of air in turn. This is achieved by opening the manual head (blue cap) on the lower manifold, then fully opening the corresponding topmeter on the upper manifold. To fully open the topmeter, remove the red locking ring and turn the topmeter 3 full turns from the closed position.
  - Turn on the water tap. As the first loop fills with water, air will discharge through the hose to the drain. Once the air stops and there is a steady flow of water, close both ports on the manifold.
  - Repeat this procedure for all UFH loops on the manifold ensuring that the valves are closed on each loop after filling.
  - Close the valves on the end caps and switch-off the mains water before disconnecting the hoses.
  - Important: If using a V5 Compact Control Pack, please remember to open the pump isolation valve.
  - If the UFH is being installed in the winter, anti-freeze can be added to the system water for protection against freezing. If used, then the pipes will need to be fully flushed with cold water prior to running the system.

The system is now ready for pressure testing.

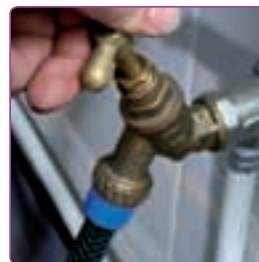
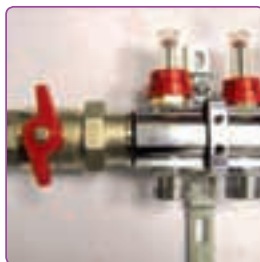

## Pressure Testing



Once the UFH pipes have been installed and filled, a hydraulic pressure test must be carried out on all loops prior to laying the screed or covering with the chosen floor coverings. A hydraulic pressure test kit is available from Uponor (Product Number 1004057).

- Isolate both the flow and return manifolds, using either the ball valves or control and lockshield valves if using the V5 Compact Control Pack.
- Ensure that all flow and return valves to the UFH loops are open.
- Use the pressure gauge on the pressure test kit to monitor pressures.
- Connect a pressure pump to the hose union and open the valve on this end cap. Ensure the other hose union valve is closed.
- Pump up the pressure in the manifold to 2 x the operating pressure (minimum 4 bar, maximum 6 bar) for at least 1 hour. After an initial slight drop in pressure as the pipes expand, there should be no further drop in pressure. Check the pressure gauge during this period to ensure that the pressure remains constant under this period.
- Decrease the pressure to the system working pressure, or a minimum of 2 bar. The system pressure will initially increase as the pipes contract under the lower pressures and will then stabilise. If the pressure has not fallen below working pressure after 1 hour the system is pressure tight.
- Uponor recommends that the system should remain under pressure whilst the floor is laid so that if any damage occurs to the pipe, the laying of the floor can be stopped and the damage repaired immediately. The floor should be laid immediately after the pressure test.
- Where there is a danger of freezing, suitable measures such as the use of glycol-based antifreeze should be taken, using the correct mixture of water and antifreeze solution. However, before start up, the glycol mixture should be thoroughly flushed out of the system and disposed of carefully.

### Use of Corrosion Inhibitors

Uponor UFH pipes will not be:

- adversely affected by corrosion inhibitors normally used in central heating systems.
- adversely affected by accidental contact with linseed oil based sealing compounds, or soldering flux. However, the latter should not be used for making joints to the pipe.
- affected by soft, hard or aggressive potable water. The pipe will not be attacked by any constituents of concrete, screeds, mortars, and is fully resistant to attack from micro-organisms.

## Comprehensive installer, design and control courses available at the Uponor Training Academy.

The Uponor Training Academy was established to offer you a range of industry accepted courses. Starting with a comprehensive installer training course and moving through to design and control oriented workshops, encompassing techniques associated with Uponor Plumbing and Underfloor Heating products.

We are also able to offer bespoke workshops, tailored to suit your individual needs. Our main training academy is a purpose built facility close to Junction 20 off the M1, in the market town of Lutterworth.

### ◉ **UFH Installer Course**

A two-day course at our purpose-built facility in Lutterworth. The course is aimed at both new and experienced users of our products.

Day 1 gives a thorough understanding of applications of UFH in our theory suite. Day 2 follows with practical exercises in our hands-on practical suite.

### ◉ **Design Considerations & Controls Course**

Recommended as a follow-up to the UFH Installer course, this course is usually aimed at experienced installers and gives a basic understanding of system requirements from a design point of view. You will also have the opportunity to look at any new Uponor products which are now available.

### ◉ **Controls Wiring Course**

Uponor has recently launched a range of innovative water temperature and air temperature controls. Consequently, we are now offering an informative course aimed at installers and electricians, who wish to increase their product knowledge with respect to Uponor control systems.

### ◉ **Plumbing Applications Course**

A tailored course to show the advantages of Uponor plumbing applications over traditional materials. Delegates who will benefit from this course would have a previous plumbing knowledge. The course includes Pipe technology, MLCP Riser System, Multi-layer, Pex pipes, RTM, Pre-Insulated Pipe & Practical training.

### ◉ **Merchant Course**

A course which gives an overview of Uponor products and their applications. Mainly aimed at Merchants but can be specifically tailored to give a bespoke course for installers, or anyone who requires specific guidance in the application of UFH or Plumbing. Please contact us to discuss your requirements.

**On-Site Training is available upon request.**

\*All courses are inclusive of lunch and course materials.

All courses are held at our purpose built facility close to J20 M1, in the market town of Lutterworth.

Training Academy: 01455 551363  
Uponor Head Office: 01455 550355  
email: [training.uk@uponor.com](mailto:training.uk@uponor.com)  
[www.uponor.co.uk](http://www.uponor.co.uk)



# Starting-up & System Operation



This section helps you check and start-up the UFH system.

• <b>System Start-up</b> _____	<b>86</b>	• <b>Auto-Balance</b> _____	<b>88</b>
<b>TM manifold loop balancing procedure</b>		• <b>System Operation &amp; Maintenance</b> _____	<b>89</b>
<b>LS manifold loop balancing procedure</b>		• <b>Trouble Shooting</b> _____	<b>90</b>



## Starting-up the System

### System Start-Up

When the system has been connected to the heat source and all pumps, controls, valves and bypasses fitted, the system should be checked and started as follows.

- Where applicable, ensure that the screed has had sufficient time to cure in accordance with manufacturers instructions and relevant British Standards, typically between 21 – 28 days.
- Check and ensure all electrical controls are wired correctly and in accordance with the latest edition of IEE Wiring Regulations, or ETCI National Rules for Republic of Ireland.
- The system set-up and control arrangement should be checked to ensure that it conforms to Uponor's recommendations.
- Check that the system is filled with water and fully vented of air and all isolating valves are fully open. Once this is complete, the pumps should be run for 5 minutes and a final check made to ensure that all air has been vented from the system.
- Check that the boiler or heat source is operating in accordance with the manufacturers instructions and set to run with a flow temperature of a minimum 15°C higher than the UFH design flow temperature. If the heat source is directly controlling the design flow water temperature, it should be set to the starting temperature of the system.
- The flow rate for each UFH loop (in litres/min) is regulated by topmeters fitted to the flow header on TM manifolds or lockshield balancing valves fitted to the flow header on LS manifolds. Set each loop by using the typical flow rate tables (overleaf) as a guide, and then carry out the balancing procedure that follows.
- If Uponor wireless controls or 12V controls with thermostats incorporating auto-balance technology are used, then hydronic balancing will be carried out automatically by the control system, as long as the thermostat auto-balancing mode is switched on.

### TM manifold loop balancing procedure:

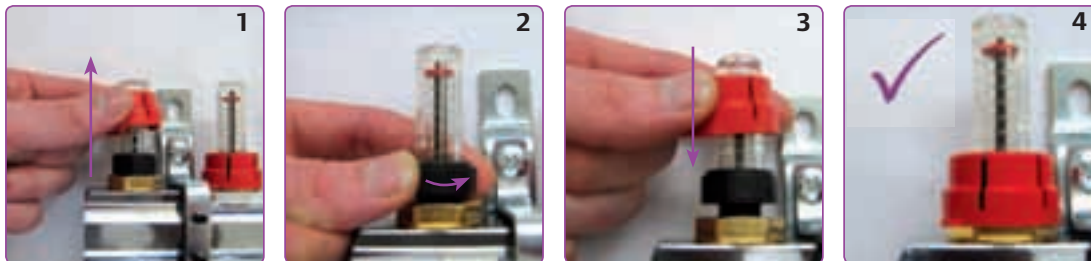

- Remove the red cover from the topmeter as shown in Fig 1. If the topmeter has been opened it needs to be closed by turning it clockwise. All topmeters should be fully closed at the start of the commissioning process.
- Ensure that all manifold return valves are fully closed (remove thermal actuators if fitted and replace with blue manual caps).
- Open the return valve on one loop and adjust the setting of the corresponding topmeter, until the design flow rate is reached, by turning the topmeter anticlockwise from its fully closed position as shown in Fig 2. It is important that the system and UFH pumps are running. Note, three full turns from shut will fully open the topmeter. It is not possible to adjust the topmeter further than this setting.
- Once the design flow rate is achieved the red locking ring should be refitted over the topmeter as shown in Fig 3.
- The topmeter will not turn at all if the red locking ring is fitted correctly. Fig 4 shows a correctly fitted locking ring.

### LS manifold loop balancing procedure:

- You will need the Technical Printout for your project together with a 5mm Allen Key to carry out the procedure. The Technical Printout shows the number of turns from closed for each lockshield valve.
- Ensure all lockshield valves are fully closed.
- Open each lockshield valve the required number of turns according to the Technical Printout. It is important to ensure that each valve is set to the correct value for the individual loop/area it serves.
- After the valve has been opened, replace and tighten the cap finger tight.



### Loop balancing for both TM and LS manifolds (continued)

- Repeat the process for each loop, then go back and carry out fine adjustments, because each loop will have a mutual effect on the others. If the valve topmeter or lockshield is fully open and design flow rate is not achieved adjustment on the pump speed may be necessary.
- If removed, refit all thermal actuators.
- With the electric power off, initially set all room thermostats 5°C above current room temperature so that they call for heat.
- Set the water temperature control at the lowest possible setting (between 25 - 30°C).
- Switch on the UFH system and ensure UFH pumps are running and all relevant valves are open. Remember that the thermal actuators take some time to operate and there will be a 2 – 4 minute delay before they are fully open.
- If the foregoing procedures have been completed satisfactory, turn all room thermostats down and wait for the system to stop.
- When the system has stopped, turn up one room thermostat at a time and wait for the system to start. Then confirm that the correct circuit (loop) actuator(s) has opened for that particular room and immediately turn the room thermostat down again in that room.
- Wait until the system has stopped and then repeat the process on a room by room basis, ensuring that every actuator is controlled by the correct thermostat and that each one switched the system on and off. This should also include the boiler being switched on and off, providing there are no other user circuits, e.g. radiators and/or hot water primary circuits, calling for heat.
- Run the system at the lowest possible setting for at least 3 days, before raising the water temperature to the maximum design temperature, which should be maintained for at least a further 4 days.
- Set the room thermostats to the required levels and programme the system controls to run as required.
- When running normally, the temperature difference between the manifold flow and return connections may be between 5-10°C. To help assess the situation strap on thermometers are available. See the main price guide for details.

### Final Loop Balancing

When the furnishings have been installed into the building and normal working conditions achieved, the loops may require a final balancing. The system should be run at design temperatures for at least one week before this is done.

### General Commissioning

Commissioning is required to enable the system to meet its design specification and comply with the energy efficiency requirements of the Building Regulations. Commissioning should only be carried out after the system has been run gently for adequate time to allow floors to dry out (**do not use the UFH to cure the screed**). The building work should be complete with all external doors and windows closed.

All safety checks relating to the boiler operation, controls wiring and water connections should have been performed in accordance with manufacturers instructions and with statutory requirements before system commissioning is commenced.

Floor heating systems are typically designed to operate with a water flow temperature of approximately 40 – 50°C and a return temperature of 5 – 10°C less. There are occasions, mainly concerning floor coverings, when resistance to heat flow is so great that the flow temperature must be increased to raise the floor surface temperature to achieve sufficient heat output.

### Tables showing typical flow rates; 20mm PEX

Loop Length (m)	Floor Heat Output (W/m <sup>2</sup> )		
	50	70	100
60	1.7 l/m	2.4 l/m	3.4 l/m
80	2.3 l/m	3.2 l/m	4.6 l/m
100	2.9 l/m	4.0 l/m	5.7 l/m
120	3.4 l/m	4.8 l/m	-

**Note: Values based upon 20mm Uponor PEX pipes spaced at 300mm centres and with full coil usage, with a 7.5°C flow/return water temperature drop.**

### 16mm PEX or 16mm MLC

Loop Length (m)	Floor Heat Output (W/m <sup>2</sup> )		
	50	70	100
50	1.0 l/m	1.4 l/m	2.0 l/m
75	1.5 l/m	2.1 l/m	3.0 l/m
100	2.0 l/m	2.8 l/m	-
120	2.4 l/m	-	-

**Note: Values based upon 16mm Uponor MLC or 16mm Uponor PEX pipes spaced at 200mm centres and with full coil usage, with a 7.5°C flow/return water temperature drop.**

### 12mm PEX (Floating Floor System)

Loop Length (m)	Floor Heat Output (W/m <sup>2</sup> )	
	50	70
40	0.5 l/m	0.7 l/m
60	0.8 l/m	1.1 l/m
80	1.0 l/m	1.4 l/m
100	1.3 l/m	N/A

**Note: Values based upon 12mm PEX pipes spaced at 125mm centres and with a 7.5°C water temperature drop.**

### 12mm PEX (Tracked Plywood Panel System)

Loop Length (m)	Floor Heat Output (W/m <sup>2</sup> )	
	50	70
40	0.6 l/m	0.9 l/m
60	0.9 l/m	1.3 l/m
80	1.2 l/m	1.7 l/m
100	1.5 l/m	N/A

**Note: Values based upon 12mm PEX pipes spaced at 175mm centres and with an 8.5°C water temperature drop.**

## Auto - Balance

Auto Balance Technology (ABT) is patented technology unique to Uponor and only exists in our system. The function replaces the need for manual balancing of the loops. Instead of balancing the system for one peak load, the system calculates the actual energy needs in the single rooms over the heating season and adapts to those needs.

This gives more even floor temperatures, faster system reactions with lower energy consumption than any standard on/off system. You can save up to 12% on energy usage with ABT.

It goes on balancing through the changing seasons and throughout the household's changing lifestyle and usage patterns. Most of all, you will love the true radiant comfort only Uponor radiant thermostats provide!

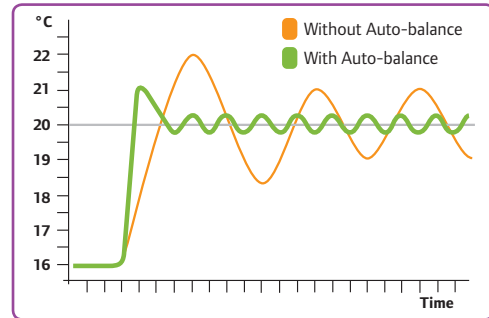

The graph illustrates the fluctuations in temperature over time of standard on/off control systems, compared to more accurate and consistent comfort levels of Dynamic Energy Management.

### Uponor Controls at a Glance

Features	Wireless	Wired 12V	Wired 230V
Wireless	✓		
Radiant thermostat technology	✓		
Auto Balance Technology	✓	✓	
Comfort Setting	✓		
Diagnostics	✓		
Room Check	✓		
Room Bypass	✓		
Heating and Cooling Mode	✓	✓	
Set Back/Eco mode	✓	✓	
Floor Sensor	✓	✓	✓
Quick Connectors	✓	✓	
Auto Channel Linking	✓	✓	
Digital Display	✓	✓	✓
Public Thermostat	✓	✓	✓
Programmable Thermostat	✓	✓	✓
Dial Thermostat	✓	✓	✓

Wireless	Wired 12V	Wired 230V
<ul style="list-style-type: none"> <li>Control up to 36 zones through one interface</li> <li>Up to 12% energy saving due to better efficiency</li> <li>No manual balancing</li> <li>More accurate control</li> <li>Improved heat distribution</li> <li>Easy to operate</li> <li>Auto-balancing, no recalculation required</li> <li>Easy trouble shooting</li> <li>Changing the floor covering will not affect the system</li> </ul>	<ul style="list-style-type: none"> <li>Can control up to 12 zones</li> <li>Economical and secure low voltage thermostat cabling</li> <li>Range of thermostats to choose from</li> <li>Thermostats can be connected to a floor sensor</li> <li>Auto-balancing, no recalculation required. Digital Thermostats only.</li> <li>Setpoint values can be limited</li> </ul>	<ul style="list-style-type: none"> <li>Surface or flush mounted thermostats available</li> <li>Controls up to 8 zones and 16 thermal actuators</li> <li>2 Channel set back time control</li> <li>Choice of programmable or non programmable thermostats</li> <li>Thermostats can be connected to floor sensors</li> </ul>

---

## System Operation

---

### System Operation

Once the system has been correctly balanced and commissioned, there is very little to concern the client with operating Uponor Underfloor Heating.

### Time Clocks

The UFH time clock is to be programmed to suit the building users requirements, depending upon their occupied and unoccupied periods during day and week; for example, when they go to work, or at what time they retire in the evening. It is normal for the UFH to be switched on approximately 2-3 hours before comfort conditions are required, especially true with screeded floors, due to the thermal lag associated with UFH. This also means the system can be switched-off approximately 2-3 hours before the end of the heating/occupied period.

The actual thermal lag is dependent upon the thermal mass of the floor structure; the thicker the screed the longer it will take to warm up and visa versa. Where the floor is of wooden structure, whose mass is typically one third of that of a screed floor, the response will be proportionately faster.

### Air Thermostats

These can be adjusted to provide optimum comfort control. Once comfort conditions have been met, further adjustment of the thermostat should not be necessary. When a room thermostat setting is altered to call for more heat, providing the new setting is within the systems capabilities, it may take a while before a higher temperature is felt in the room. The rate of heat build up under most conditions will be fairly constant. Turning the thermostat up to higher temperature levels than it is desired to achieve cannot increase this rate.

### Unoccupied Set-Back (USB)

USB is ideal for UFH because it reduces warm-up times between unoccupied and occupied heating periods throughout the day/week by lowering the desired room temperature by approximately 4°C during unoccupied periods. This ensures that the system response at the next occupied period is faster, because to heat the screed from cold each morning would be impractical (not applicable with wooden or lightweight flooring systems). However, a well insulated screed floor may only lose 1.5 – 2°C over an 8 hour period, therefore when switched to unoccupied set-back, the UFH system will effectively be off except in cold weather.

### Water Temperature Controls

The design water temperature should be set when the system is first commissioned and further adjustment is not usually necessary, except when the system is under performing (see Trouble Shooting section). Adjustment is either directly on the water temperature control valves or on the Climate Controller. See specific installation instructions for further details.

### Pump Speed

Increasing the pump speed will increase the flow rate and slightly improve the system response time.

### Maintenance

Since the heating loops are embedded and the pipe does not corrode, no maintenance is necessary for the pipes. When the UFH system is not in use, e.g. during the summer months, the system should be run for 2 – 3 minutes each week to exercise the pumps and valves (the Climate Controller has a built-in pump and valve exercise programme). Pumps, valves and controls will require servicing as per the manufacturers instructions.

As for any plumbing joints, all joints at the manifold and flow and return should be checked regularly for any signs of leakage.

In older systems it is advisable to flush the system through with clean water to remove any sediment build-up.

## Trouble Shooting

As described in earlier sections, the UFH system operation is relatively straightforward. Hot water from the primary heat source (boiler) is blended with the return water from the UFH secondary circuit at the mixing valve and distributed, via the secondary UFH pump, to the distribution manifold and into a series of UFH loops/circuits of pipe embedded within the floor. Normally, there is room temperature control, which will open and close a single or series of actuators mounted on the manifold, or prior to the manifold (single zone), depending upon the room requirement. If one or all thermostats are calling for heat, there is a boiler interlock switch to energise the boiler.

The majority of problems are usually simple installation problems, relating to wiring or plumbing, or design problems, with regard to the limitations of UFH and its suitability for the purpose intended.

In all cases where an electrical fault is reported it is always prudent to check the obvious before replacing components.

- Is there an electrical supply?
- Is it switched on?
- Are there any fuses that may have blown and need replacing?
- Are any components overloaded?
- Is everything wired correctly?

Under no circumstances replace a fuse with a higher rating than stated for that piece of equipment.

If the water arriving at the manifold (prior to entering the mixing valve) is either cold or below the design temperature, check:

- the boiler is firing
- the primary pump is fitted
- the primary pump is working
- the boiler is of adequate size
- the primary pipework is sufficiently sized
- the primary pumps are large enough

### Further UFH Problems:

#### If a loop or loops fail to warm, when other zones are working correctly.

General things to look for:

- Check that the corresponding manifold valves are open
- Check that there is a demand from the corresponding room thermostat and/or the thermal actuator is open on demand.
- There may be an air lock in the loop, which will require purging. Either shut down all other loops by closing the valves at the manifold or turn down all other room thermostats. This will concentrate all pump pressure to the problem loop and may shift the air blockage. If all else fails the loop can be flushed through with high-pressure water following the instructions detailed in Filling, Venting and Pressure Testing.

If circulation is apparent but poor, it may be that the regulating control valve on the manifold requires adjustment.

- Check that all pump isolating valves are fully open.

#### If a room fails to warm.

General things to look for:

- That the room thermostat fitted is calling for heat and that the valve has opened using the visual window on the actuator.
- That the room thermostat is connected to and communicating to the correct actuator(s).
- That the room thermostats are not operating in temperature set-back mode.
- That the flow temperature is correct as it enters the floor loops. Although typical design water temperatures are suggested throughout this guide, there is some element of a learning curve with UFH, as on some occasions the design water temperature may need to be raised after commissioning and once the system has been in operation during a heating season.
- That the primary flow and return connections are installed correctly and not crossed over at the UFH manifold.
- That the primary water temperature is not too low. This needs to be at least 15°C higher than the UFH system water temperature, especially when using a V5 Compact Control Pack.
- That the high limit thermostat on the V5 Compact Control Pack is not set too low.
- That the lockshield valve on the V5 Compact Control Pack is set correctly
- Thermal resistance of floor covering is not too high, as this could reduce the floor heat output.

#### If the system is too noisy.

General things to look for:

- There is no air in the system
- That all pipes are firmly clipped in place and that the manifold brackets are tight.
- That the UFH pump speed is not too high.
- That excessive pressure from another circulator in the system is not interfering (hence the importance of having a primary bypass).

#### If the running costs are high.

General things to look for:

- That the UFH system is correctly electrically connected to the boiler to prevent short cycling and to ensure that the boiler is not running when it is not required.
- That the room temperatures and thermostat settings are not too high (typical comfort temperatures are 20°C in living quarters and 18°C in bedrooms).
- For any open windows or draughts. It is not unknown for windows to be opened in cold weather, as the internal comfort remains constant with thermostatic controls.
- That the boiler is running correctly. Has it been serviced and/or commissioned by an approved engineer.
- That the floor downward losses are high due to inadequate level of floor insulation.

**The design water temperature is not met**

General things to look for:

- Check all control valves are correctly installed in their correct orientation and that any remote sensors are installed and located in a suitable position.
- Check the temperature settings are as per design and adjust as necessary, depending on the water temperature control system used.
- Check the primary water temperature is not too low. This needs to be at least 15 degrees in excess of the UFH system water temperature.

**The system is losing pressure.**

General things to look for:

- If the system is losing pressure either during testing and/or after the system has been filled, but the flooring has not been laid, simple visual/manual checks around the manifold and along each loop of pipe should identify the problem area.
- If there are no clear visual signs, each loop/circuit may require a separate pressure test to identify the exact location.
- If the floor has been laid, identification of the fault can be traced through signs of a wet patch around the leak. Obviously to make the repair, the floor will have to be raised. In screed floors, excavate carefully in the centre of the wet patch.
- Any leaks on the manifold are generally due to the connection and any loose nuts and unions will require tightening.

**Repairs.**

To make a repair to the pipe, follow the processes below;

**Repairing the pipe:**

- Isolate the damaged pipe loop at the manifold.
- Cut out the damaged section of pipe.
- Prepare both ends of pipe using the pipe cutter. For MLC pipe use a bevelling tool.
- On panel systems, remove a small section of the floating panel or fixed tracked panel, to accommodate the compression fittings.

- Slide the compression adaptor nut over each end of pipe, together with olive on PEX pipes, prior to inserting the insert/sleeve into each end.
- Offer both ends of pipe/inserts to the compression coupler and tighten both nuts.
- Ideally, the joint will require an inspection chamber in case further maintenance is required. However, in practice this is often not practical, and the fitting is wrapped in suitable tape before burying in the screed (ensure approval with the building inspector is sought prior to doing this).
- Pressure test the system again before laying the floor covering.

**Items Required**

- Plastic pipe cutter
- Denso tape (for solid floors)

**For 16mm MLC pipe:**

- 16mm MLCP adaptor for 15mm compression body, 2 x product code 1013805
- 15mm copper compression coupler

**For 12mm PEX pipe:**

- 12mm PEX adaptors for 15mm compression coupler, 2 x product code 1013813
- 15mm copper compression coupler

**For 16mm PEX pipe:**

- 16mm PEX insert for 15mm compression coupler, 2 x product code 1058934
- 15mm copper compression coupler

**For 20mm PEX pipes:**

- Eurocone compression adaptor 20mm PEX x 3/4" FT, 2 x product code 1010629
- 3/4" compression coupling, 1 x product code 1006641



## Q&E TOOL DEALS



Milwaukee  
Expander Tool Set  
1057166

## MLCP TOOL DEALS

Contact your Uponor representative or speak to your local plumbers or builders merchant today for more details.



Mini 32  
Pressing Tool for MLCP  
1007096

[www.uponor.co.uk](http://www.uponor.co.uk)



**Come and see us!**  
For a full list of exhibitions and events visit [www.uponor.co.uk](http://www.uponor.co.uk)

# Tools and Accessories



Using our tools and accessories ensures full system warranty. That means we have tested the entire system range of pipes, fittings, and pressing jaws as a complete system. Special deals available on tool purchases and hire. Contact your Uponor representative or speak to your local plumbers and builders merchant for more details.

- **MLCP Tools** \_\_\_\_\_ **94**
- **PEX Tools** \_\_\_\_\_ **95**
- **General Tools and Accessories** \_\_\_\_\_ **96**

## Underfloor Heating - MLCP Tools and Accessories

### MLCP pliers



Special pipe cutting pliers for Uponor MLCP with an outer diameter of 12-20mm; with corrugated tube cutting attachment.

Description	Code	Qty
Pipe cutting pliers 12-20mm	<b>1006636</b>	1
Spare blades for cutting pliers	<b>1006637</b>	1

### Pipe cutter



Pipe cutter for use with Uponor MLCP.

Description	Code	Qty
Pipe cutter 14-32mm	<b>1013719</b>	1
Spare cutting blade	<b>1013721</b>	1

### Polystyrene hot cutter



Ideal for use when installing floating floor panels to cut extra grooves and channels in the insulation. Supplied head cuts 16mm groove. Optional 20mm head available (1002072).

Description	Code	Qty
110V	<b>1006293</b>	1
230V	<b>1006290</b>	1

### Pressure test plug



Reusable plug with 1/2" FT designed for pressure-testing of Uponor MLCP installations.

Description	Code	Qty
16mm	<b>1013756</b>	10

## Underfloor Heating - PEX Tools and Accessories

### Plastic pipe cutters



Cost effective PEX pipe cutters to leave the perfect jointing finish.

Description	Code	Qty
Pipe cutter 12-28mm	<b>1001369</b>	1
Pipe cutter 12-40mm	<b>1001370</b>	1

### Polystyrene hot cutter head (20mm)



Optional 20mm head only for cutting extra pipe channels into PEX 20 floating floor panels to fit 20mm diameter pipe. For connection to polystyrene hot cutter 1006290 230V or 1006293 110V.

Description	Code	Qty
20mm head	<b>1002072</b>	1

### Pipe and conduit cutter



This tool is specially designed for cutting pipe-in-conduit. Conduit cutter is guarded to prevent damage to the pipe inside the conduit. Maximum pipe diameter 22mm.

Description	Code	Qty
Cutter	<b>1009031</b>	1

Generate a code online in minutes... [www.one-pack.co.uk](http://www.one-pack.co.uk)



## Professional underfloor heating!

An easy to order and install pack for solid screed floors up to 75m<sup>2</sup>

**AUTOBALANCE**  
TECHNOLOGY

with every single pack!

Up to **12%**  
Energy Saving!

- No manual balancing
- Improved heat distribution
- Accurate, quicker control
- Up to 25% quicker reaction time
- Easy to operate





## Underfloor Heating - General Tools and Accessories

### Hydraulic test pump



Use to pressure test all UFH and plumbing installations before screeding and before commissioning. Capacity 5 litres. Maximum pressure 25 bar. Connection is 1/2" MI.

Description	Code	Qty
5 Litres 25 BAR	<b>1004057</b>	1

### Kombi gun



For all Uponor pipe from 15mm to 20mm (multi-layer composite pipe and cross-linked polyethylene pipe) to all common UK underfloor heating insulation boards. For use with Kombi Klips 1002296 and 1002297.

Description	Code	Qty
Kombi Gun	<b>1002295</b>	1

### Uponor Tape



Wide tape for sealed joining of Uponor insulation products.  
Roll width: 50mm  
Roll Length: 66m

Description	Code	Qty
Width 50mm x Length 66m	<b>1000012</b>	1

### Uponor Tape Dispenser



For taping of insulation sections and edges.  
For use with tape 1000012

Description	Code	Qty
Tape dispenser	<b>1000142</b>	1



## Underfloor Heating - General Tools and Accessories

### Pipe De-coiler NEW

Suitable for both PEX and MLCP pipes. Includes coil retention arms and de-coiling eyelet.



Description	Code	Qty
De-coiler	1058662	1

### Mobile Pipe De-coiler NEW

Suitable for both PEX and MLCP pipes. Includes coil retention arms and de-coiling eyelet.



Description	Code	Qty
De-coiler	1058663	1



## Optimal Productivity and Performance

**Remove work steps... 28dB impact noise reduction can remove the need for installing a resilient acoustic layer. Built in membrane removes the need for installing a polythene layer above the insulation. Reduce overall build programme. Halve the time of a UFH installation or halve the installation cost! Visit [www.uponorsas.com](http://www.uponorsas.com) for more information.**

---

## Notes

---

A series of horizontal dotted lines for taking notes.

---

## Notes

---

A series of horizontal dotted lines for taking notes.



## Uponor Training Academy

The Uponor Training Academy was established to offer you a range of industry accepted courses. Starting with a comprehensive installer training course and moving through to design and control oriented workshops, encompassing techniques associated with Uponor Plumbing and Underfloor Heating products.

We are also able to offer bespoke workshops, tailored to suit your individual needs. Our main training academy is a purpose built facility close to Junction 20 off the M1, in the market town of Lutterworth.

### All courses include:

- \* Course Materials
- \* Uponor delegate packs
- \* Exclusive 'on the day' Tool Deals
- \* Lunch



Training Academy: 01455 551383  
 Uponor Head Office: 01455 550355  
 email: [training.uk@uponor.com](mailto:training.uk@uponor.com)  
[www.uponor.co.uk](http://www.uponor.co.uk)

Copyright © Uponor (Uponor Limited.)  
Reproduction of any part of this publication for any purpose is not permitted without the prior written permission of Uponor Limited.

The information in this publication is correct at the time of going to press.

Uponor reserves the right to alter specifications and operating parameters for all our Underfloor Heating & Plumbing Systems at any time as part of our policy of continuous product development.

### Guarantee

Uponor Limited ("Uponor") guarantees [to the original purchaser/customer] that pipes and fittings sold by it are free of defects in materials or manufacture under normal conditions of use for a period of 25 years and in case of electrical and mechanical products for 2 years from the date of installation. This guarantee only applies to the products stored, installed, tested and operated in accordance with the fitting instructions issued by Uponor and valid at the time the products were installed.

Where a claim is made during the guarantee period and products are proven to be defective in materials and/or manufacture at the time of delivery, Uponor will supply replacement products free of charge. This is the exclusive remedy under this guarantee.

Uponor disclaims any warranty or guarantee not expressly provided for herein, including any implied warranties of merchantability or fitness for a particular purpose. Uponor further disclaims any and all responsibility or liability for losses, damages and expenses, including special, direct, indirect, incidental and consequential damages, whether foreseeable or not, including without limitation any loss of time or use or any inconvenience arising from the ownership, installation or use of the products sold hereunder.

This guarantee does not affect the statutory rights of the consumer.

## Classifications, Approvals & Affiliations

All Uponor pipes are manufactured in accordance with the international quality standard of ISO9001 and to the environmental standard of ISO14001.

Uponor products have been independently assessed and meet the requirements of the UK Water Regulations.

Uponor hold the BBA certificates 87/1799 and 92/2741

Uponor is affiliated with the following organisations:



### Uponor Limited

Head Office  
Gilmorton Road  
Lutterworth  
Leicestershire  
LE17 4DU

T 01455 550355  
F 01455 550366  
E [enquiries.uk@uponor.com](mailto:enquiries.uk@uponor.com)  
W [www.uponor.co.uk](http://www.uponor.co.uk)