

**TRITON**

**T300si  
electric shower**



**Installation and  
operating  
instructions**

INSTALLERS PLEASE NOTE THESE INSTRUCTIONS ARE TO BE LEFT WITH THE USER

2180280J May 2008

<b>CONTENTS</b>	<b>Page</b>
Important safety information	1
Introduction	2
Specifications	2
Advice to users	2
Main components	3
Electrical requirements	4
Water requirements	6
Siting of the shower	7
Fitting the remote pack	9
Plumbing connections	11
Fitting the bulkhead	14
Electrical connections	16
Fitting the control panel bracket	17
Fitting the control panel	18
Fitting the remote pack cover	18
Commissioning	19
Operating the shower	21
Operating functions	23
Cleaning	24
Instructions for installers and service engineers only	25
Spare parts	26
Fault finding	27 - 28
Guarantee, service policy, etc.	rear cover

To check the product suitability for commercial and multiple installations, please contact Triton's specification advisory service before installation.

Telephone: 0870 067 3767

Facsimile: 0870 067 3334

E mail: [technical@tritonshowers.co.uk](mailto:technical@tritonshowers.co.uk)

**PLEASE READ THIS IMPORTANT SAFETY INFORMATION**

- ◆ Products manufactured by Triton are safe and without risk provided they are installed, used and maintained in good working order in accordance with our instructions and recommendations.
- ◆ **WARNING: DO NOT operate shower if frozen, or suspected of being frozen. It must thaw out before using.**
- ◆ **DO NOT operate the unit if the showerhead or spray hose becomes damaged.**
- ◆ DO NOT restrict flow out of shower by placing showerhead in direct contact with your body.
- ◆ DO NOT operate the shower if water ceases to flow during use or if water has entered inside the unit because of an incorrectly fitted cover.
- ◆ **WARNING: If restarting the shower immediately after stopping, be aware that a slug of hot water will be expelled for the first few seconds.**

**1 GENERAL**

- 1.1** Isolate the electrical and water supplies before removing the cover.
- 1.2** Read all of these instructions and retain them for later use.
- 1.3** DO NOT take risks with plumbing or electrical equipment.
- 1.4** Isolate electrical and water supplies before proceeding with the installation.
- 1.5** The unit must be mounted onto the finished wall surface (on top of the tiles). Do not tile up to unit after fixing to wall.
- 1.6** Contact Customer Service (*see back page*), if any of the following occur:
- a)** If it is intended to operate the shower at pressures above the maximum or below the minimum stated.
  - b)** If the unit shows a distinct change in performance.
  - c)** If the shower is frozen.
- 1.7** If it is intended to operate the shower in areas of hard water (above 200 ppm temporary hardness), a scale inhibitor may have to be fitted. For advice on the Triton Scale Inhibitor, contact Triton Customer Service.
- 1.8** The showerhead must be cleaned regularly with descalent to remove scale and debris, otherwise restrictions to the flow on the outlet of the unit will result in higher temperatures and could also cause the Pressure Relief Device in the unit to operate.
- 1.9** This product is not suitable for mounting into steam rooms or steam cubicles.

**2 PLUMBING**

- 2.1** The plumbing installation must comply with Water Regulations, Building Regulations or any particular regulations as specified by Local Water Company or Water Undertakers and should be in accordance with BS 6700.
- 2.2** The supply pipe must be flushed to clear debris before connecting to the shower unit.
- 2.3** DO NOT solder pipes or fittings within

300 mm of the shower unit, as heat can transfer along the pipework and damage components.

- 2.4** DO NOT fit any form of outlet flow control as the outlet acts as a vent for the heater can.
- 2.5** DO NOT use excessive force when making connections to the flexible hose or showerhead, finger tight is sufficient.
- 2.6** All plumbing connections must be completed before making the electrical connections.

**3 ELECTRICAL**

- 3.1** The installation must comply with BS 7671 'Requirements for electrical installations' (IEE wiring regulations), building regulations or any particular regulations as specified by the local Electrical Supply Company.
- 3.2** This appliance **MUST** be earthed.
- 3.3** In accordance with 'The Plugs and Sockets etc. (Safety) Regulations 1994', this appliance is intended to be permanently connected to the fixed wiring of the electrical mains system.
- 3.4** Make sure all electrical connections are tight to prevent overheating.
- 3.5** Fuses do not give personal protection against electric shock.
- 3.6** A 30mA residual current device (RCD) **MUST** be installed in all UK electric and pumped shower circuits. This may be part of the consumer unit or a separate unit.
- 3.7** Switch off immediately at isolating switch if water ceases to flow during use.
- 3.8** Other electrical equipment i.e. extractor fans, pumps must not be connected to the circuits within the unit.
- 3.9** Switch off at isolating switch when not in use. This is a safety procedure recommended with all electrical appliances.
- 3.10** As with all electrical appliances it is recommended to have the shower and installation checked at least every two years by a competent electrician to ensure there is no deterioration due to age and usage.

## INTRODUCTION

This book contains all the necessary fitting and operating instructions for your Triton T300si electric shower — please read them carefully.

The shower installation must be carried out by a suitably qualified person and in the sequence of this instruction book.

Care taken during the installation will ensure a long, trouble-free life from your shower.

## SPECIFICATIONS

### Electrical

Nominal power rating at 240V	Nominal power rating at 230V
8.5kW – (40A MCB rating)	7.8kW – (40A MCB rating)
9.5kW – (40A MCB rating)	8.7kW – (40A MCB rating)
10.5kW – (45A MCB rating)	9.6kW – (40A MCB rating)

### Water

Inlet connection – 15 mm diameter.

Outlet connection – ½" BSP male thread.

### Entry Points

Water – bottom or back.

Cable – top or back.

### Materials

Backplate, cover, controls, showerhead – ABS.

Sprayplate – Acetal.

Elements – Minerally insulated corrosion resistant metal sheathing.

### Dimensions (in mm)

	control panel	remote pack
Height	235	338
Width	180	208
Depth	40	98

### Standards and Approvals

Splashproof rating IPX4.

Complies with the requirements of current British and European safety standards for household and similar electrical appliances.

Complies with requirements of the British Electrotechnical Approvals Board (BEAB).

Meets with Compliance with European Community Directives (CE).

Replacement parts can be ordered from Customer Service. See 'spare parts' for details and part numbers.

## ADVICE TO USERS

### ELECTROMAGNETIC COMPATIBILITY

**This product is intended for domestic use.**

This product may temporarily be affected by electromagnetic disturbance near to the installation that could cause temporary operation of the low pressure indicator together with switching to the cold power selection. If problems persist, contact Triton Customer Service (see rear page).

The following points will help you understand how the shower operates:

**a.** The electric heating elements operate at a constant rate at your chosen power setting. It is the rate of the water passing through the heater unit which determines the shower temperature at a given setting. (The slower the flow the hotter the water becomes, and the faster the flow the cooler the water).

**b.** During the winter the cold water supply will be cooler than in the summer months. Therefore, the temperature of the water will vary from season to season on any one setting of the control buttons, e.g. if you have chosen 'Economy' power for your preferred shower temperature in the summer, you will have to select the 'High' setting and adjust the temperature control during the winter months.

**c.** The stabiliser valve minimises variations in shower temperature during mains water pressure changes. If changes in shower temperature are experienced during normal use, it will most likely be caused by the water pressure falling near to or below the minimum level. The drop in pressure may be due to water being drawn off at other points in the house while the shower is in use. If pressure drops appreciably below the minimum, the heating elements will automatically cut out.

**If ever the water becomes too hot and you cannot obtain cooler water, first check the showerhead has not become blocked.**

**IMPORTANT:** When first installed (or following replacement of the PRD), the unit will be empty. It is essential the heater assembly contains water before the elements are switched on. As this unit has electronic control, it is vital that the commissioning procedure is followed. Failure to carry out this operation will result in damage to the unit and will invalidate the guarantee.

## MAIN COMPONENTS

### Remote pack (fig.1)

1. Top cable entry
2. Bottom pipe entry
3. Rear pipe entry area
4. Rear cable entry area
5. Wall screw fixing
6. Terminal block
7. Printed circuit board
8. Stabilising valve
9. Solenoid valve
10. Guide pockets
11. Can and element assembly
12. Thermal safety cut-out (main)
13. Earth connection
14. Control cable clamp
15. Thermal cut-out (outlet)
16. Outlet pipe
17. Transformer
18. Connector socket
19. Stepper motor
20. Trimplate

### Control panel (fig.2)

21. Control cable exit
22. Access plate

### Other items

- Screw fixing kit
- Instructions, guarantee, etc.

**NOTE:** Not all wiring shown for reasons of clarity **Fig.1**

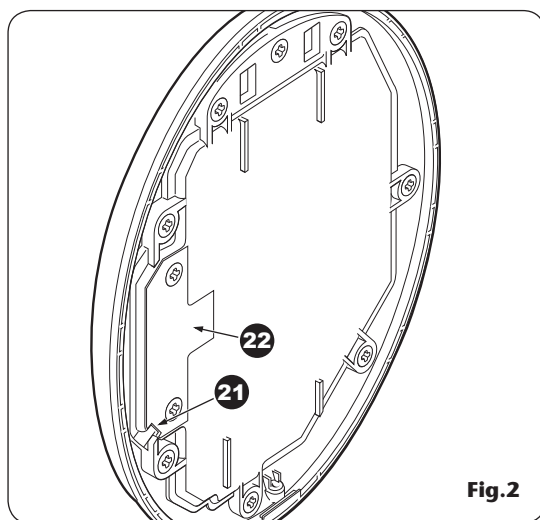
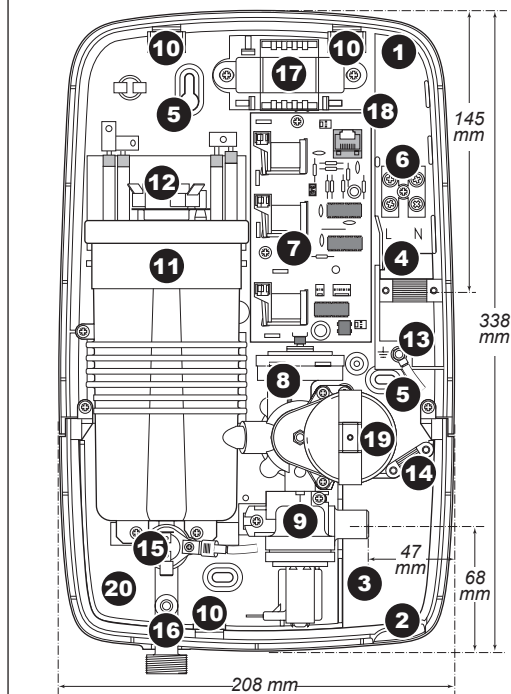

## ELECTRICAL REQUIREMENTS

**WARNING!**  
**THIS APPLIANCE MUST BE EARTHED**

The installation, supply cable and circuit protection must conform with BS 7671 (IEE wiring regulations) and be sufficient for the amperage required.

The following notes are for guidance only:

- 1 The shower must only be connected to a 230-240V ac supply. If you are installing a shower with a kilowatt rating above 9kW, it is advisable to contact the local electricity supply company.
- 1.1 The electrical rating of the shower is shown on the rating label (**Fig.3**) within the unit.

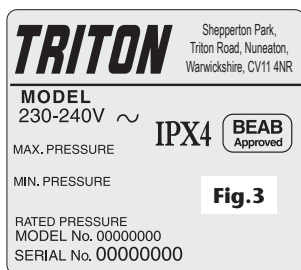

**Fig.3**

**Fig.4** Schematic of installation circuit

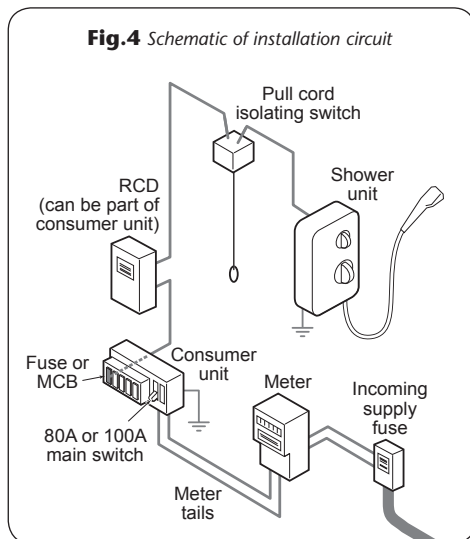

- 2 Before making any sort of electrical connection within the installation make sure that no terminal is live. If in any doubt, switch off the whole installation at the mains supply and remove the correct fuse.
- 3 The shower must be connected to its own independent electrical circuit. IT MUST NOT be connected to a ring main, spur, socket outlet, lighting circuit or cooker circuit.
- 3.1 The electrical supply must be adequate for the loading of the unit and existing circuits.
- 4 Check your consumer unit (main fuse box) has a main switch rating of 80A or above and that it has a spare fuse way which will take the fuse or Miniature Circuit Breaker (MCB) necessary for the shower (**Fig.4**).
- 4.1 If your consumer unit has a rating below 80A or if there is no spare fuse way, then the installation will not be straightforward and may require a new consumer unit serving the house or just the shower.
- 4.2 You will need to contact the local electricity company. They will check the supply and carry out what is necessary.
- 5 For close circuit protection DO NOT use a rewirable fuse. Instead use a suitably rated Miniature Circuit Breaker (MCB) or cartridge fuse (**see Table A**).
- 5.1 A 30mA residual current device (RCD) must be installed in all UK electric and pumped shower circuits. This may be part of the

**Table A**

unit rating	CIRCUIT PROTECTION	
	MCB	cartridge fuse
7.0kW	30/32A	30A
7.5kW	32A	35A
8.0kW	40A	35A
8.5kW	40A	45A
9.0kW	40A	45A
9.5kW	40/45A	45A
10.5kW	45A	45A

- 6 A 45 amp double pole isolating switch with a minimum contact gap of 3 mm in both poles must be incorporated in the circuit.
- 6.1 It must have a mechanical indicator showing when the switch is in the OFF position, and the wiring must be connected to the switch without the use of a plug or socket outlet.
- 6.2 The switch must be accessible and clearly identifiable, but out of reach of a person using a fixed bath or shower, except for the cord of a cord operated switch, and should be placed so that it is not possible to touch the switch body while standing in a bath or shower cubicle. It should be readily accessible to switch off after using the shower.
- 7 Where shower cubicles are located in any rooms other than bathrooms, all socket outlets in those rooms must be protected by a 30mA RCD.
- 8 The current carrying capacity of the cable must be at least that of the shower circuit protection (see Table B).
- 8.1 To obtain full advantage of the power provided by the shower, use the shortest cable route possible from the consumer unit to the shower.
- 8.2 It is also necessary to satisfy the disconnection time and thermal constraints which means that for any given combination of current demand, voltage drop and cable size, there is a maximum permissible circuit length.
- 9 The shower circuit should be separated from other circuits by at least twice the diameter of the cable or conduit.
- 9.1 The current rating will be reduced if the cabling is bunched with others, surrounded by thermal loft or wall insulation or placed in areas where the ambient temperature is above 30°C. Under these conditions, derating factors apply and it is necessary to select a larger cable size.
- 9.2 In the majority of installations, the cable will unavoidably be placed in one or more of the above conditions. This being so, it is strongly recommended to use a minimum of 10mm cabling throughout the shower installation.
- 9.3 In any event, it is essential that individual site conditions are assessed by a competent electrician in order to determine the correct cable size and permissible circuit length.

**Table B**

<b>Twin and earth PVC insulated cable Current carrying capacity</b>		
<b>Installed in an insulated wall</b>	<b>In conduit trunking</b>	<b>Clipped direct or buried in a non-insulated wall</b>
6 mm <sup>2</sup> 32A	6 mm <sup>2</sup> 38A	6 mm <sup>2</sup> 46A
10 mm <sup>2</sup> 43A	10 mm <sup>2</sup> 52A	10 mm <sup>2</sup> 63A
16 mm <sup>2</sup> 57A	16 mm <sup>2</sup> 69A	16 mm <sup>2</sup> 85A
<b>Note: Cable selection is dependent on derating factors</b>		

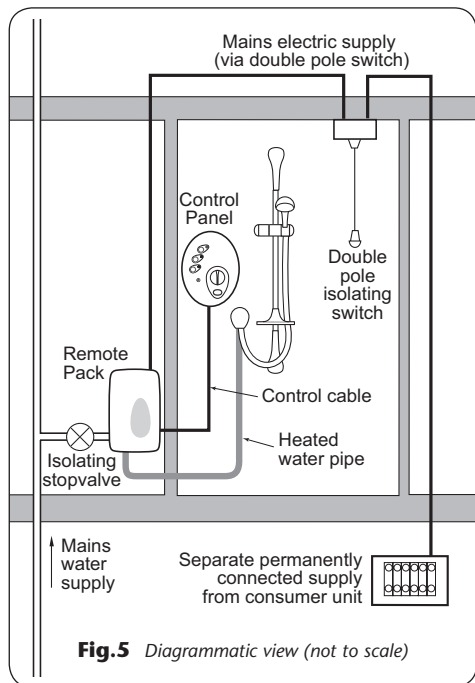

**Fig.5** Diagrammatic view (not to scale)

## WATER REQUIREMENTS

The installation must be in accordance with Water Regulations/Bylaws.

To ensure activation of the heating elements, the shower must be connected to a mains water supply with a minimum pressure of 100kPa (1.0 bar) at a minimum flow rate of eight litres per minute for the 8.5kW rated model and nine litres per minute for the 9.5kW rated model.

For the 10.5kW rated shower, the minimum running pressure must be 150kPa (1.5 bar) at a minimum flow rate of eleven litres per minute.

For all units the maximum static pressure must be no greater than 1000kPa (10 bar).

If in any doubt, the pressure should be checked.

**Note:** If the stated flow rate is not available, it may not be possible to achieve optimum performance from the unit throughout the year.

During periods of high ambient temperatures it may be necessary to select a low power setting to achieve your preferred shower temperature.

The water supply can be taken from a cold water storage cistern provided there is a minimum head of ten metres (fifteen metres for the 10.5kW model). Minimum head is the vertical distance from the base of the cistern to the showerhead. It must be an independent supply to the shower only.

If it is intended to operate the shower at pressures above the maximum or below the minimum stated, contact Triton Customer Service for advice.

**Fig.5** shows a typical system layout.

**Do not use jointing compounds on any pipe fittings for the installation.**



## SITING OF THE SHOWER

### WARNING!

The shower must not be positioned where it will be subjected to freezing conditions.

**IMPORTANT:** If installing onto a tiled wall always mount the unit on the surface of the tiles. NEVER tile up to the unit.

The heated water pipe and control cable are both 3.5 metres approximately in length, so position the remote pack within this distance from the control panel and bulkhead.

**Note:** The control cable is supplied with protective dust covers fitted at either end.

DO NOT remove them until all installation work is complete and ready for the final connection to the control panel and remote pack.

Refer to **fig.6** for correct siting of shower.

Position the control panel where it will NOT be in direct contact with water from the showerhead. Position the remote pack vertically and accessible for maintenance purposes.

**Note:** Water Regulations requires that the showerhead be 'constrained by a fixed or sliding attachment so that it can only discharge water at a point not less than 25 mm above the spill-over level of the relevant bath, shower tray or other fixed appliance' (**fig.6**). The use of the supplied soap dish will usually meet this requirement, but if the showerhead can be placed within a bath, basin or shower tray, then a double check valve, or a similar device, must be fitted in the supply pipework to prevent back-flow.

### Pressure relief safety device

A pressure relief device (PRD) is designed into the shower unit which complies with European standards. The PRD (**fig.7**) provides a level of appliance protection should an excessive build up of pressure occur within the shower.

If the PRD operates, then water will eject from the clear PRD tube, so make sure the tube, when eventually installed, is routed carefully to waste.

In the event of the PRD operating, turn off the electricity and water supplies to the shower

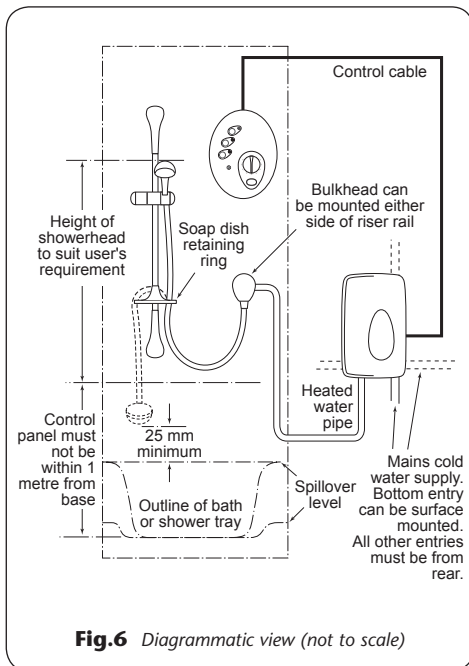

### WARNING!

Under no circumstance should the control cable be extended or shortened, or the heated water pipe extended. This will impair the performance of the shower and invalidate the guarantee.

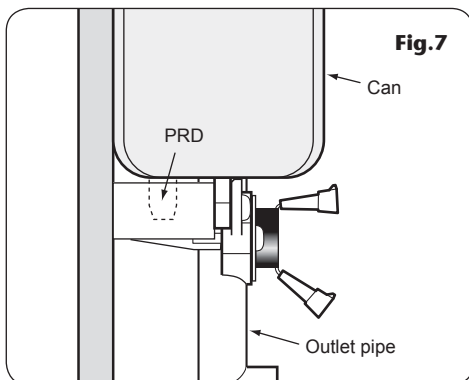

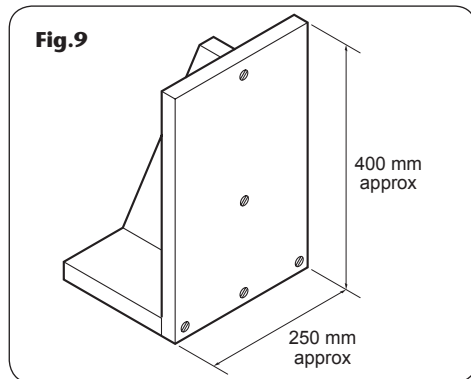
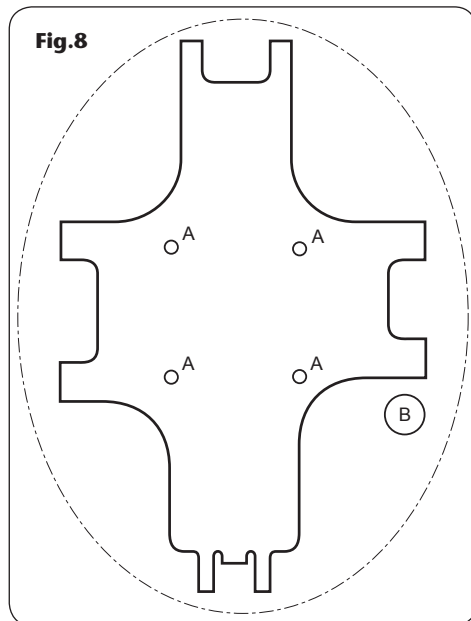

at the isolating switch and stopvalve. Contact Customer Service for advice on replacing the PRD.

DO NOT operate the shower with a damaged or kinked shower hose, or a blocked showerhead which can cause the PRD to operate.

When commissioning, the showerhead must be removed from the flexible hose. If not removed, again it may cause the PRD to operate.

### **Routing control cable and heated water pipe**

After deciding the position of the riser rail and control panel, you may wish first to channel a route for the semi rigid heated water pipe and the control cable from the remote pack position to the control panel and bulkhead position.

The control cable must exit the shower cubicle wall through a 15 mm hole — marked 'B' on the supplied fixing template (**fig.8**). Place the template on the wall and mark the position of the 15 mm hole.

Drill and channel a route as required. Place and position the control cable between the remote pack and control panel. Make sure there is enough slack cable at the remote pack end in order for the control panel to be removed should the need arise for future maintenance

Within the shower cubicle, the end of the control cable outer sleeve must be flush with the finished wall surface to allow easy installation, and the inner cable should be loose and able to slide through the outer sleeve when finally installing the control panel.

It is advisable to seal the outer sleeve in the hole using a silicon seal.

Make good the wall, including any tiling, as all the units must be screwed to the finished wall surface.

**IMPORTANT:** In the shower area the control cable linking the remote pack and control panel must be secured by routing through conduit, trunking or capping if embedding in the wall. It must NOT be surface clipped.

## FITTING THE REMOTE PACK

**IMPORTANT:** The remote pack must be mounted on a flat surface which covers the full width and length of the backplate. It is important that the wall surface is flat otherwise difficulty may be encountered when fitting the cover and subsequent operation of the unit may be impaired.

The remote pack must always be positioned so that there is easy access for installation and maintenance. Where this is difficult or a suitable wall is not available, a mounting bracket similar to that shown in (fig.9) can be used.

Position the remote pack in a dry area, ideally in a linen or airing cupboard. It must be well ventilated and not covered with towels, sheets, etc.

**IMPORTANT:** The remote pack **MUST** be mounted vertically. **DO NOT MOUNT IT HORIZONTALLY.**

### Loft installation notes

If the remote pack is installed in a loft area the following requirements must be met for future servicing purposes:

- a. There must be no risk of the remote pack, heated water pipe or PRD tube becoming frozen.
- b. The remote pack must not be covered with any form of insulating material that may give rise to electrical circuits overheating during periods of high ambient temperature.
- c. A safe means of access must be provided into the loft, e.g. via a fixed loft ladder.
- d. The remote pack must be installed upright and in an accessible and safe location.
- e. Ceiling joists must be adequately boarded to provide safe and unobstructed access to, from and around the remote pack.
- f. There must be adequate lighting in the loft for servicing purposes.

### Procedure

Unscrew the top and bottom retaining screws (fig.10) and lift cover from the backplate. To allow access to the pipe and cable connections, remove the two screws (fig.11) and take off the trimplate.

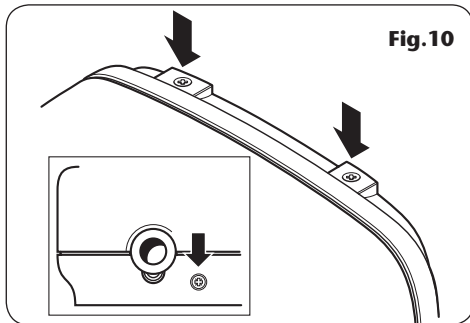

Fig.10

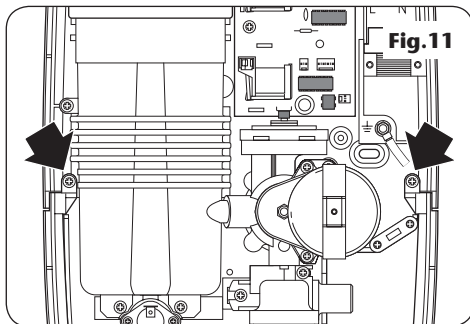

Fig.11

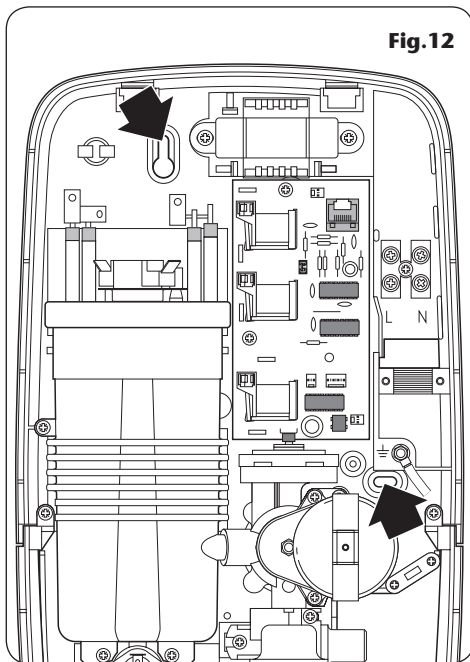
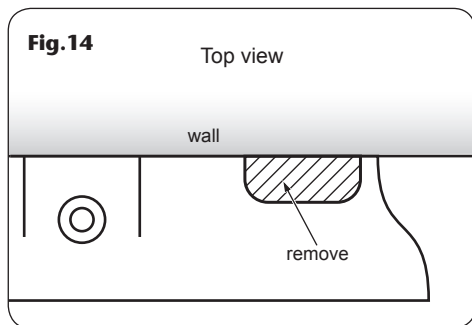
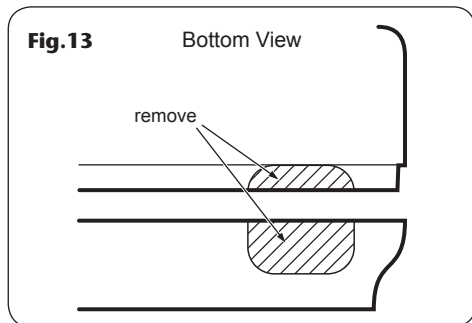

Fig.12



After choosing the site for the shower, use the backplate as a template and mark two fixing holes (**fig.12**).

Drill and plug to suit the fixing screws supplied. *(The wall plugs provided are suitable for most brick walls — use an appropriate masonry drill, but if the wall is plasterboard or a soft building block, you must use special wall plugs and an appropriate drill bit).*

Screw top fixing screw into position leaving the base of the screw head protruding 6 mm out from the wall.

Entry positions for the mains water are from the bottom or from the rear.

Cable entry is via the top or rear.

**Note:** Deviations from the designated entry points will invalidate product approvals.

If a bottom surface entry is required for the mains cold water then the necessary hole will need to be cut out in the trimplate and cover (**fig.13**).

If a surface cable entry from the top is required then the relevant hole in the backplate will need to be cut out (**fig.14**).

Hook the backplate over the top screw and fit the bottom fixing screw into position.

DO NOT fully tighten the screws at this stage, as the fixing holes are elongated to allow for out of square adjustment after the plumbing connections have been completed.

## PLUMBING CONNECTIONS

### Plumbing to be carried out before wiring

#### WARNING!

**The outlet of the shower acts as a vent and MUST NOT be connected to anything other than the hose and showerhead supplied.**

DO NOT use jointing compounds on any pipe fittings for the installation.

DO NOT solder fittings near the shower unit as heat can transfer along the pipework and damage components.

Compression fittings MUST be used to connect to the inlet of the remote pack (push-on fittings MUST NOT be used as the remote pack inlet may not fully enter this type of fitting to provide a watertight seal).

**Note:** An additional stopvalve, complying with Water Regulations, MUST be fitted in the mains water supply to the remote pack as an independent means of isolating the water supply should maintenance or servicing be necessary.

**IMPORTANT:** Before completing the connection of the water supply to the inlet of the remote pack, flush out the pipework to remove all swarf and system debris. This do this, connect a hose to the pipework and turn on the mains water supply long enough to clear the debris to waste.

#### Procedure

Turn off the water supply either at the mains stopvalve or the isolating stopvalve. Connect the mains water supply to the inlet of the remote pack via a 15 mm x 15 mm elbow compression fitting (not supplied).

If installing a feed pipe from the rear or bottom, the centre of the inlet valve to the wall surface is 20 mm (**fig.15**).

**Note:** If entry is from the rear, the nut of the compression fitting will be partially behind the surface of the wall (**fig.15**). This area must be left clear when plastering over the pipework in order to make the nut accessible for future adjustments.

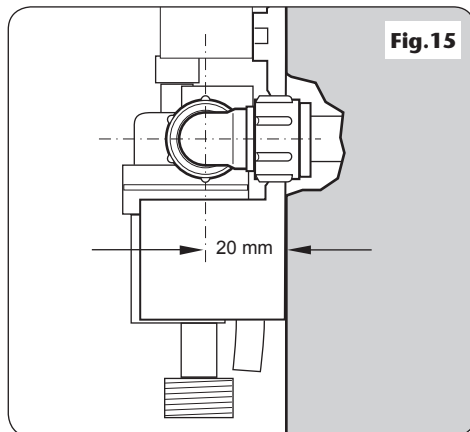

**Fig.16**

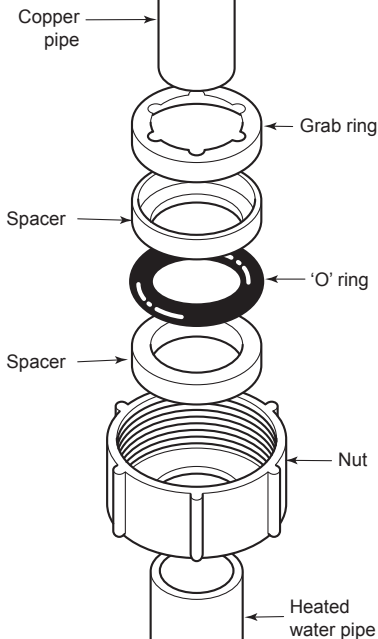

DO NOT use excessive force when making these connections. It is strongly recommended to use a correct size open ended spanner. Using adjustable pipe grips may damage internal components.

Make sure the backplate is square on the wall and tighten the two retaining screws which hold it to the wall.

Turn on the mains water supply and check for leaks in the pipework connection to the remote pack.

**Note:** At this stage no water can flow through the unit.

The remote pack is connected to the bulkhead outlet by means of a semi rigid white 10 mm plastic water pipe which carries the heated water. This pipe can be channelled in a wall, plumbed through a wall or hidden behind a studded wall. The pipe can be run up to 3.3m approx. away from the remote pack. Any surplus can be cut off as required.

**Note:** The water outlet does not need to be vertically above or below the control panel. If required the outlet adaptor and control panel can be placed on different walls as long as the control panel is not in the direct line of any spray when in use.

Push on the fittings to both ends of the heated water pipe as follows:

Slide the nut over the water pipe (**fig.16**) followed by the 'O' ring sandwiched between the two spacers. Make sure the spacers have their flat sides towards the 'O' ring. Push the grab ring onto the pipe so that it locates about five to ten millimetres from the end. Finally, insert the supplied 8 mm copper pipe into the end of the water pipe until it is flush. This is to provide extra support to the plastic pipe.

The pipe connects to the remote pack using the outlet extension (**fig.17**) which is screwed onto the remote pack outlet pipe. Alternatively, a 1/2" x 15 mm female thread to compression elbow can be screwed onto the outlet pipe, sealing the joint with PTFE tape.

**Fig.17**

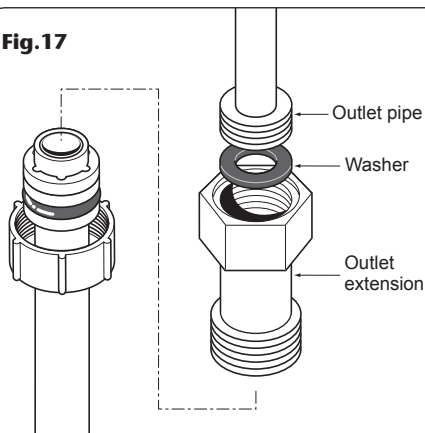

Fit the clear plastic PRD tube through the can outlet pipe boss situated at the rear of the outlet pipe (**fig.18**) and push firmly on to the PRD outlet.

The other end of the PRD tube needs to be directed to a suitable and visible waste.

**Note:** Check the correct tubes have been used as they are similar in diameter and length (the PRD tube is clear).

**IMPORTANT:** Do not bend either the PRD tube or heated water pipe sharply as they will kink and restrict the water flow. If a tight bend is required in the heated water pipe cut the pipe and rejoin with standard 10 mm elbow compression fittings.

Insert a 25 mm length of 8 mm copper pipe (four are supplied, but more may be required) to provide support for the plastic pipe under the olive ring. If possible, the connections should be accessible so that adjustment can be carried out when required.

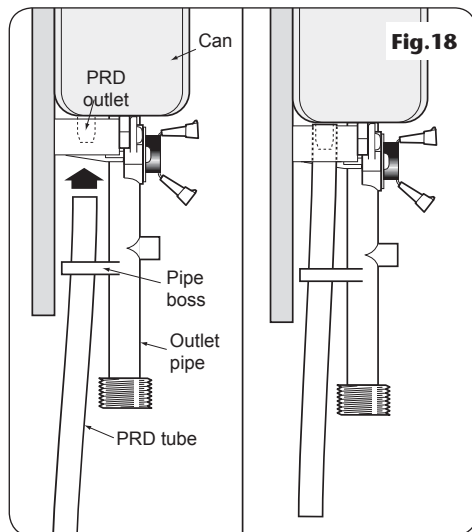

Fig.19

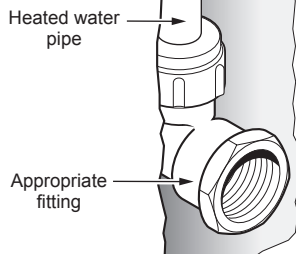

Fig.20

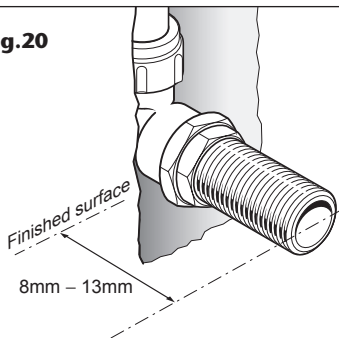

Fig.21

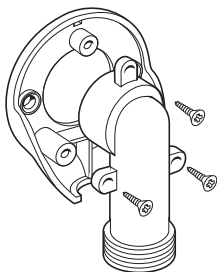
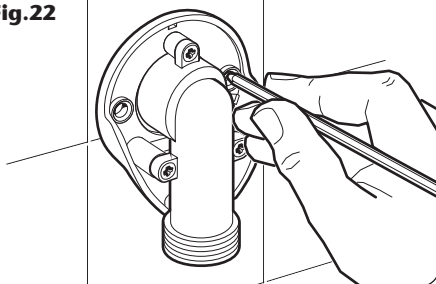

Fig.22



## FITTING THE BULKHEAD

Route the heated water pipe to the outlet position and push on the fittings as shown in **(fig.16)**. Connect the heated water pipe to a  $\frac{1}{2}$ " BSP x 15 mm female thread elbow or straight coupler compression fitting **(fig.19)**.

**Note:** This fitting is not supplied as variations in installations requires selection of the most appropriate fitting.

Screw the supplied male-thread connector into the female fitting **(fig.20)** using PTFE tape to give a watertight joint.

**Note:** The male-thread connector supplied has a shoulder. If fitting into a flush wall, make an additional 8 mm allowance for this shoulder at the finished surface. The connector can be cut to size if required.

The threaded connector should protrude from the wall surface between 8 mm and 13 mm.

Make good the wall.

The bulkhead and its cover are supplied assembled. Separate the two halves by carefully prising apart at the smaller of the two elbow apertures.

Secure the elbow to the bulkhead body with the three screws supplied **(fig.21)**.

Screw the bulkhead assembly onto the threaded connector temporarily. Mark the position of the two fixing holes **(fig.22)** securing the bulkhead to the wall.

**Note:** If screw thread protrudes too far out of the wall, it can be cut to the correct length using a hacksaw.

Unscrew and remove the bulkhead assembly. Check the location of the pipe in the wall before drilling.

Drill and plug the holes using the wall plugs supplied. *(The wall plugs provided are suitable for most brick walls — use an appropriate masonry drill, but if the wall is plasterboard or a soft building block, you must use special wall plugs and an appropriate drill bit).*



If fitting to a hollow wall structure, it may be preferable to secure the bulkhead by applying a bead of silicon seal to the back of the bulkhead.

Apply PTFE tape to the threaded connector.

Screw the bulkhead assembly onto the threaded connector until tight to the wall and the two fixing holes are aligned. Secure to the wall with the two screws supplied (**fig.23**).

Finish by clipping the cover onto the bulkhead making sure the protruding legs locate in the bulkhead body.

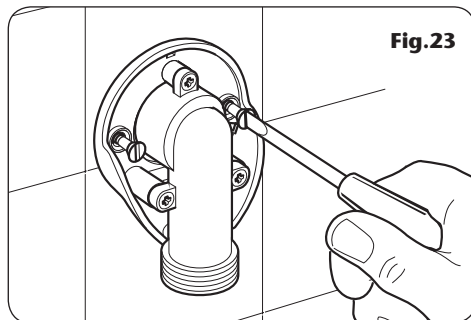

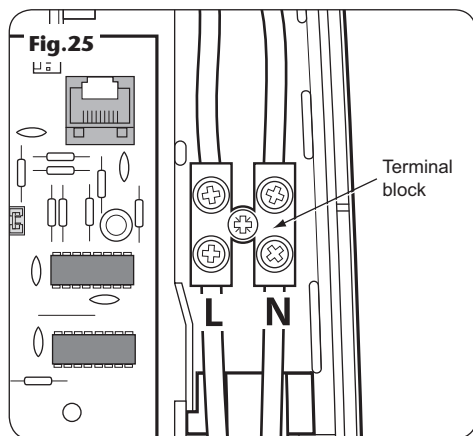
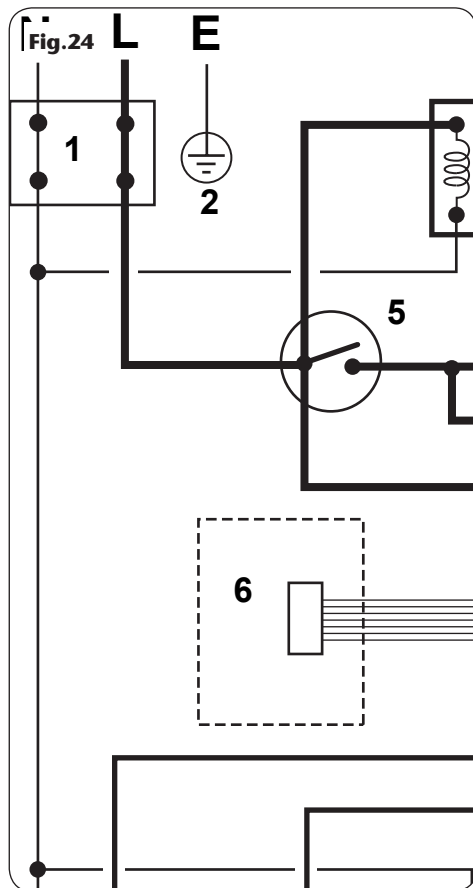

## ELECTRICAL CONNECTIONS

SWITCH OFF THE ELECTRICITY SUPPLY AT THE MAINS.

**Fig.24** shows a schematic wiring diagram.

The cable entry points are shown in **fig.1**.

The cable can be surface clipped, hidden or via 20 mm conduit.

**Note:** Conduit entry can only be from rear.

Route the cable into the shower unit and connect to the terminal block (**fig.25**) as follows:

Earth cable to terminal marked **E** 

Neutral cable to terminal marked **N**

Live cable to terminal marked **L**

**IMPORTANT:** Fully tighten the terminal block screws and check that no cable insulation is trapped under the screws. Loose connections can result in cable overheating.

**Note:** The supply cable earth conductor must be sleeved. The outer sheath of the supply cable must be stripped back to the minimum.

The supply cable must be secured either by routing through conduit or in trunking or by embedding in the wall, in accordance with current IEE regulations.

The use of connections within the unit, or other points in the shower circuit, to supply power to other equipment i.e. extractor fans, pumps etc. will invalidate the guarantee.

**Note:** The elements on UK models are to 240V specification and will give a lower kW rating if the voltage supply is below 240V.

## FITTING THE CONTROL PANEL BRACKET

### WARNING!

**Under no circumstance should the control cable be extended or shortened, as not only will it impair the performance of the shower but will also invalidate the guarantee.**

Align the supplied fixing template (**fig.8**) with the 15 mm control cable hole already drilled. Mark the four fixing holes marked 'A' on the template. Drill and plug using the plugs supplied, or suitable cavity fixings.

Using the screws supplied, secure the mounting bracket to the wall (**fig.26**).

**Note:** The mounting bracket must be fitted on the surface of the tiles.

The control panel is connected to the remote pack by means of a supplied length of control cable complete with a plug at either end. Either end of the cable can be plugged to the remote pack PCB (**fig.27**) or the control panel PCB.

Cable entry into the control panel is via the opening on the back of the main body of the control panel. Remove the two screws and remove the access panel (**fig.28**) to reveal the connector socket.

Cable entry into the remote pack is through one of the built in cut-outs.

Remove the protective dust covers from both ends of the control cable.

Once the cable has been plugged into the socket inside the control panel, refit the access panel, making sure the cable exits through the slot at the bottom corner of the access panel (**fig.29**).

**IMPORTANT:** Enough free play should be left in the cable to allow for future removal of the control panel for servicing purposes.

Make sure the cable clamp in the remote pack is used to secure the control cable (**fig.30**).

**DO NOT switch on the electricity supply until the cover on the remote pack and control panel have been fitted.**

Hook the control panel over the lugs on the

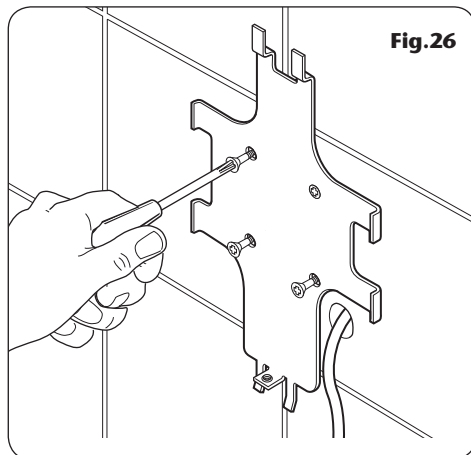

**Fig.26**

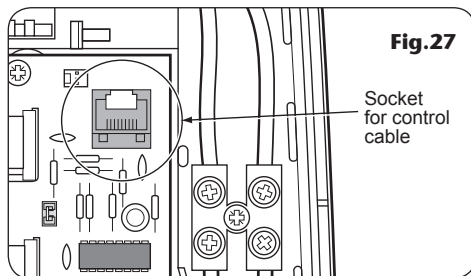

**Fig.27**

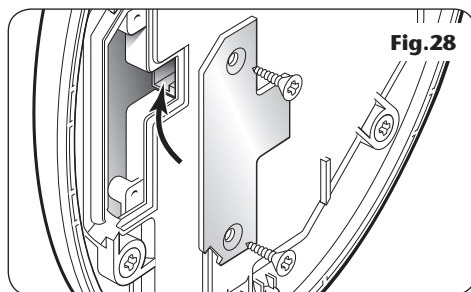

**Fig.28**

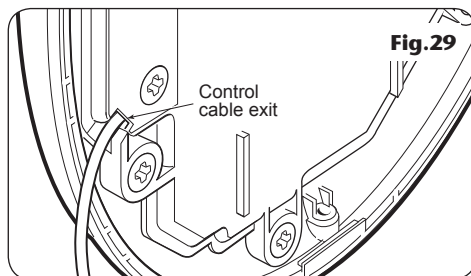

**Fig.29**

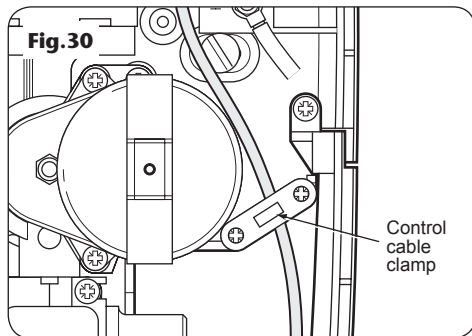

### FITTING THE CONTROL PANEL

mounting bracket (**fig.31**) and slide down into place, making sure the control cable does not get trapped.

Secure in place with the single screw at the bottom of the control panel (**fig.32**).

**Note:** To remove the panel once fitted, remove the single retaining screw, and lift off from the wall bracket lugs.

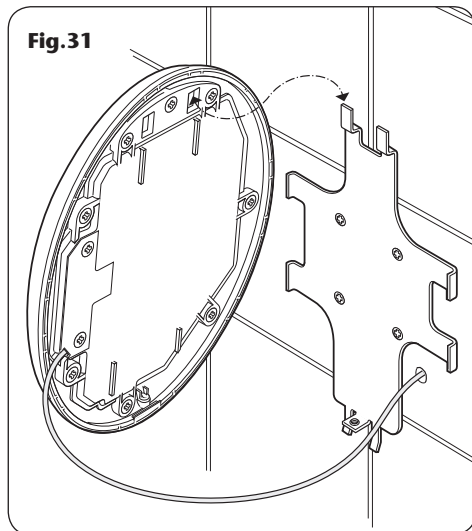

### FITTING THE REMOTE PACK COVER

Refit the trimplate and secure with the two screws.

Before replacing the cover, check on the PCB that the purge pin is located on its two pins – the factory set position, see (**fig.34**).

Locate the tags on the cover into the holes on the backplate and guide into position. Secure the cover in position with the three retaining screws.

**Note:** DO NOT fully tighten at this stage as the remote pack cover is fitted temporarily in order to carry out the commissioning procedure.

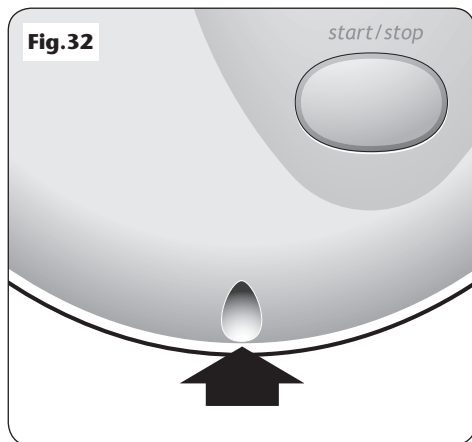

#### WARNING!

**This appliance is not intended for use by young children or infirm persons unless they have been adequately supervised by a responsible person to ensure that they can use the appliance safely.**

**Young children should be supervised to ensure that they do not play with the appliance.**

**COMMISSIONING****WARNING!**

**Before normal operation of the shower it is essential that the commissioning and purge pin procedures are correctly completed.**

The first operation of the shower is intended to flush out any remaining unit debris and to ensure the heater unit contains water before the elements are switched on. This operation must be carried out with the flexible hose screwed to the bulkhead outlet but without the showerhead attached.

Make sure the outlet of the flexible hose is directed to waste.

Partially turn on the water supply to the shower and then turn on the electricity supply at the mains supply and to the shower at the isolating switch.

The Start/Stop button surround immediately lights up and remains lit while all four LED indicators will light up in sequence alternating between the 'high', 'economy', 'cold' and 'low pressure'. This flashing sequence lasts about twenty seconds. All lights will then go out except the Start/Stop surround indicating that power is on to the unit.

Press the Start/Stop button (**fig.33**) and the 'cold' indicator will light, while at the same time the 'low pressure' indicator will flash. Water will start to flow from the flexible hose.

It will take about thirty seconds for a smooth flow of water to be obtained while air and any debris is being flushed from the shower.

When a smooth flow of water is achieved, turn the water supply fully on and allow it to run for about two minutes.

Once the flushing out has been completed, press the Start/Stop button and SWITCH OFF THE ELECTRICITY SUPPLY to the shower at the isolating switch.

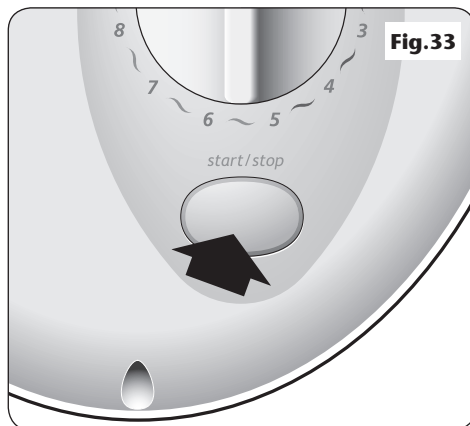

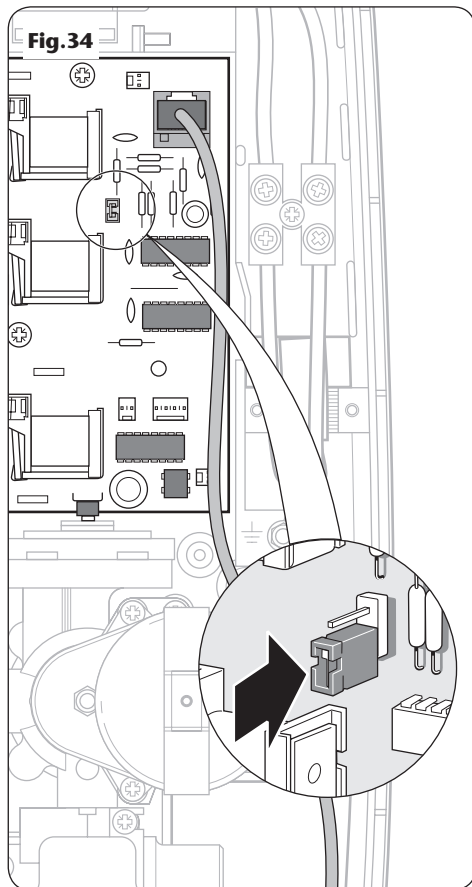

### **Purge pin procedure**

On the remote pack, unscrew the top and bottom retaining screws (**fig.10**) again and remove the cover. The purge pin is located on the remote pack PCB inside the unit (**fig.34**). Pull the pin off its two pins and, in order to store it for use at a later date, replace it on one of the pins.

### **Replacing the remote pack cover**

Locate the tags on the cover into the holes on the backplate and guide into position. Secure the cover in position with the three retaining screws.

Switch on the electric supply at the isolating switch.

Once the installation of the riser rail is complete, the shower is ready for normal operation.

## OPERATING THE SHOWER

**IMPORTANT:** Make sure the commissioning procedure has been carried out. Failure to do so will damage the unit and invalidate the guarantee.

When the electricity supply to the shower is switched on via the double pole isolating switch, the Start/Stop button surround immediately lights up and remains lit while the shower runs through a start-up routine.

All four LED indicators will light up in sequence alternating between the 'high', 'economy', 'cold' and 'low pressure'. This flashing sequence lasts about twenty seconds and will occur every time the power is switched on at the isolating switch. All lights will go out except the Start/Stop surround indicating that power is on to the unit. The shower is now ready for normal operation.

### To start the shower

Press the Start/Stop button and immediately the high power button LED will light and water will begin to flow.

### To stop the shower

Press the Start/Stop button. The phased shutdown will start and water will cease to flow after a few seconds. Note the button surround will still be lit.

### To use the control buttons

There are three control buttons — high, cold and economy — as shown in (fig.35).

The upper button is a high power setting which allows the highest flow achievable for your preferred temperature. This setting should normally be regarded as optimum shower performance throughout the year. Temperature adjustment at this setting is via the temperature control.

The centre button is an economy setting for using less power when the ambient mains water temperature is high during hot months. Temperature adjustment at this setting is via the temperature control.

Fig.35



### WARNING!

**After any servicing of mains water supply, it is essential that the commissioning and purge pin procedures are correctly completed to purge any air in the pipework.**

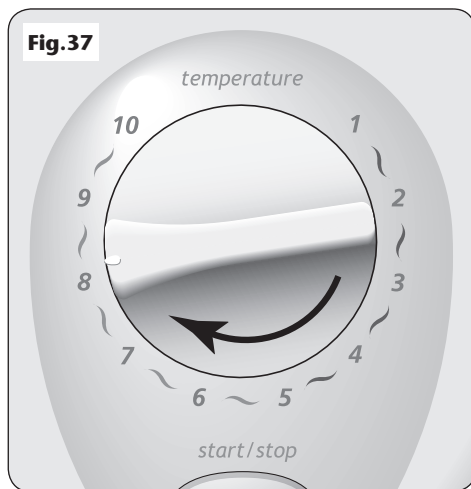

**Note:** If the stated flow rate required for the unit cannot be met due to low water pressure, it will be necessary to operate the unit on this setting during the warmer months because of flow rate limitations entering the unit.

The lower button is for cold water only. Adjusting the temperature control at this setting will only change the force of the water from the shower-head (it will not alter the water temperature).

### **To adjust the shower temperature**

The water temperature is altered by increasing or decreasing the flow rate of the water through the shower using the temperature control (**fig.35**).

After obtaining your preferred showering temperature, the number can be remembered and left as the normal setting and should only need to be adjusted for seasonal changes in ambient water temperature.

**Note:** The preferred number on 'economy' will give a different temperature to the same number position on 'high'.

### **To decrease the shower temperature**

Turn the temperature control anti-clockwise (**fig.36**). This will increase the flow of water through the shower and is indicated by lower numbers.

### **To increase the shower temperature**

Turn the temperature control clockwise (**fig.37**). This will decrease the flow of water through the shower and is indicated by higher numbers.

**CAUTION:** It is advisable to be certain that the showering temperature is satisfactory by testing with your hand before stepping under the showerhead. There will always be a time delay of a few seconds between selecting a flow rate and the water reaching the stable temperature for that flow rate.

**CAUTION:** This appliance is not intended for use by persons (including children) with reduced physical, sensory or mental capabilities, or lack of experience and knowledge, unless they have been given supervision or instruction concerning use of the appliance by a person responsible for their safety.

Children should be supervised to ensure that they do not play with the appliance.



## OPERATING FUNCTIONS

### Power on indicator (fig.38)

When the electricity supply to the shower is switched on at the isolating switch, the start/stop button surround will light.

### Low pressure indicator (fig.38)

If this indicator flashes, it means the water pressure has fallen below the minimum required for correct operation of the shower, resulting in the low pressure cut-out operating. This switches off power to the heating elements preventing any maintained temperature rises (water will continue to flow) while at the same time the 'cold' indicator will light.

When enough water pressure returns, the 'low pressure' and 'cold' indicators both extinguish and the power will automatically be restored to the power setting at the time of interruption.

### Selector mode indicators (fig.38)

Next to each control button there is an LED which lights up when the button is pressed, visually showing which shower mode is in operation.

### Phased shutdown

In use, when the Start/Stop button is pressed, power is switched off to the elements. Water continues to flow for a few seconds, flushing out any remaining hot water. This makes sure the next immediate user will not receive a slug of hot water if standing under the showerhead when starting the shower.

**Note:** The shower should always be switched off in this manner prior to isolating at the double pole isolating switch.

### Overheat cut-out

During normal operation if an overheat temperature is sensed, power to the elements will be reduced. Water will continue to flow. When the temperature has cooled sufficiently, power to the elements will be automatically restored to the previous setting at the time of interruption.



Fig.38

**Note:** In normal use, it is in order to leave the water supply permanently on to the shower unit, but as with most electrical appliances, **the unit must be switched off at the isolating switch when not in use.**

**WARNING!**

**DO NOT use abrasive or aggressive cleaning products when cleaning the shower as they may damage the unit.**

***Safety cut-out***

The unit is fitted with a non-resettable over-temperature safety device. In the event of abnormal operation which could cause unsafe temperatures within the unit, the device will disconnect the heating elements. It will require a visit from a qualified engineer to determine the nature of the fault and replace the safety device, once the unit has been repaired.

***CLEANING***

Before cleaning, turn off the unit at the isolation switch to avoid the shower being accidentally switched on.

IT IS IMPORTANT TO KEEP THE SHOWERHEAD CLEAN TO MAINTAIN THE PERFORMANCE OF THE SHOWER. The hardness of the water will determine the frequency of cleaning. For example, if the shower is used every day in a very hard water area, it may be necessary to clean the showerhead on a weekly basis.

## INSTRUCTIONS FOR INSTALLERS AND SERVICE ENGINEERS ONLY

### CLEANING THE FILTER

It is recommended that the filter is periodically cleaned in order to maintain the performance of the shower. It is essential that this operation is carried out by a competent person.

#### SWITCH OFF THE ELECTRICITY SUPPLY AT THE MAINS.

The inlet filter is situated inside the solenoid inlet (**fig.42**).

To gain access to the filter remove the cover then disconnect and remove the compression fitting. Also, depending on the incoming pipework arrangements, if there is not enough slack in the pipework, it could mean the removal of the unit from the wall.

When cleaning the filter, DO NOT use a sharp object, as it will cause damage. It is preferable to use an old toothbrush or similar.

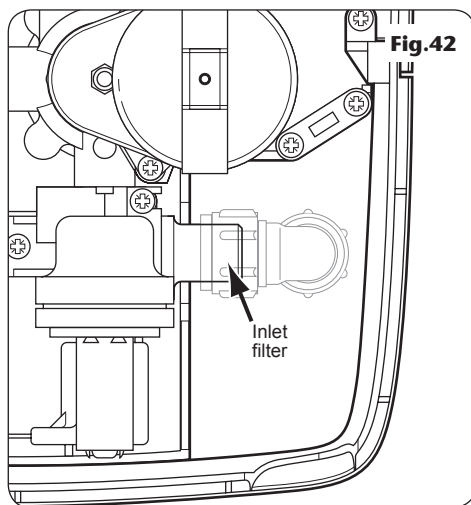

**SPARE PARTS**

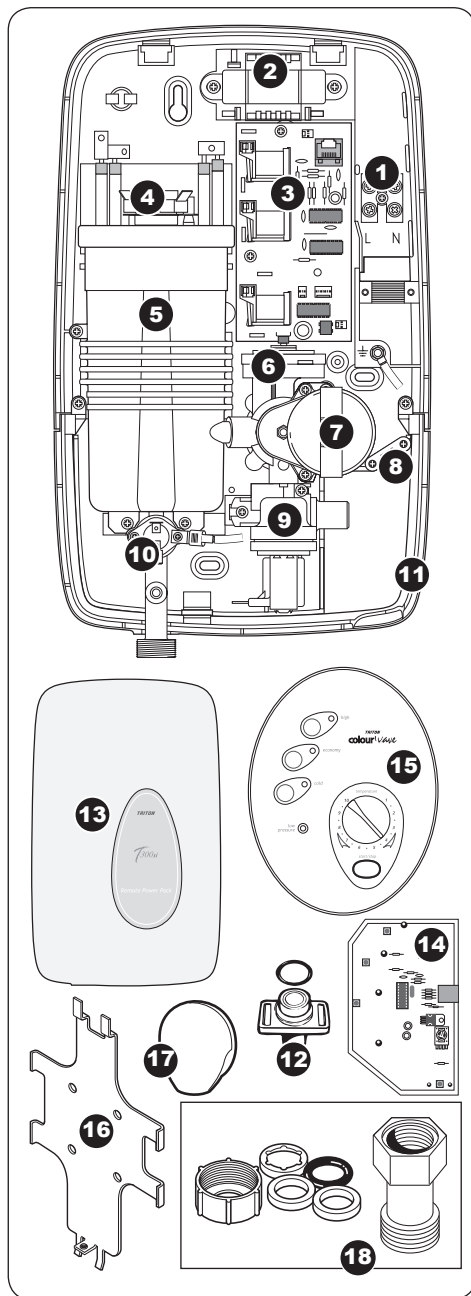

<b>Ref.</b>	<b>Description</b>	<b>Part No.</b>
<b>1.</b>	Terminal block 8.5kW & 9.5kW 10.5kW	82200930 83310260
<b>2.</b>	Transformer	22005020
<b>3.</b>	PCB – remote pack 8.5kW & 9.5kW 10.5kW	7072570 7072985
<b>4.</b>	Thermal cut-out (main)	22009860
<b>5.</b>	Heater can assembly 8.5kW 9.5kW 10.5kW	84500300 84500290 84500670
<b>6.</b>	Stabiliser valve assembly	82600780
<b>7.</b>	Stepper motor	82300170
<b>8.</b>	Mains cable clamp	7051655
<b>9.</b>	Solenoid valve	83304130
<b>10.</b>	Outlet pipe assembly	85000090
<b>11.</b>	Trimplate	7051754
<b>12.</b>	PRD & 'O' ring	83301330
<b>13.</b>	Remote pack cover	85200030
<b>14.</b>	PCB control panel	7072569
<b>15.</b>	Control panel assembly white white/chrome	87400020 87400010
<b>16.</b>	Control panel mounting bracket	7012512
<b>17.</b>	Bulkhead assembly white chrome effect	85500170 85500180
<b>18.</b>	Heated water pipe fittings kit	83304290
	– All thread fitting	7032915
	– PRD tube (clear)	22001310
	– Heated water pipe (white)	22003770
	– Inter-connecting cable	82300900
	– Wire set	83306410

**FAULT FINDING**

**IMPORTANT:** Switch off the electricity at the mains supply and remove the circuit fuse before attempting any fault finding inside the unit.

<b>Problem/Symptom</b>	<b>Cause</b>	<b>Action/Cure</b>
<b>1</b> Shower inoperable, no water flow.	<b>1.1</b> Interrupted power supply.	<b>1.1.1</b> Blown fuse or circuit breaker. Check supply. Renew or reset fuse or circuit breaker. If it fails again, consult a qualified electrician. <b>1.1.2</b> Power cut? Check other appliances and if necessary, contact local Electricity Supply Co.
	<b>1.2</b> No mains water supply to shower.	<b>1.2.1</b> Check if isolating valves are fully open. Check for a blockage in inlet filter or in pipework.
	<b>1.3</b> Unit malfunction.	<b>1.3.1</b> Have unit checked. Ring Customer Service.
<b>2</b> Water too hot.	<b>2.1</b> Not enough water flowing through the shower.	<b>2.1.1</b> Increase flow rate via temperature control. <b>2.1.2</b> Blocked showerhead — clean or replace blocked sprayplate in showerhead.
	<b>2.2</b> Blockage in supply.	<b>2.2.1</b> Check if stop valves are fully open. Check if blockage in inlet filter.
	<b>2.3</b> Increase in ambient water temperature.	<b>2.3.1</b> Readjust flow rate to give increased flow. <b>2.3.2</b> Select 'economy' power.
<b>3</b> Water temperature cycling hot/cool at intervals.	<b>3.1</b> Heater cycling on outlet thermal cut-out.	<b>3.1.1</b> See 'Water too hot' causes 2.1, 2.2 and 2.3 and their appropriate action/cures. If it continues, contact Triton Customer Service.
<b>4</b> Water too cool or cold.	<b>4.1</b> Too much flow.	<b>4.1.1</b> Reduce flow rate via temperature control.
	<b>4.2</b> Water pressure below minimum required (see rating label).	<b>4.2.1</b> Is water supply mains or tank fed ?
		<b>4.2.2</b> If tank fed, replumb to mains water supply or see 4.2.4.
		<b>4.2.3</b> If mains fed, make sure that the mains stopvalve is fully open and there are no other restrictions in the supply while shower is in use, or see 4.2.4.
	<b>4.2.4</b> Fit pump to give minimum pressure (see rating label). Contact Customer Service for advice.	
<b>4.3</b> Reduction in ambient water temperature.	<b>4.3.1</b> Readjust flow rate to give reduced flow. <b>4.3.2</b> Select 'high' power.	

## FAULT FINDING

<b>Problem/Symptom</b>	<b>Cause</b>	<b>Action/Cure</b>
	<b>4.4</b> Electrical malfunction or safety cut-out operated.	<b>4.4.1</b> Have unit checked by suitably qualified electrician or contact Triton Customer Service.
<b>5</b> Shower varies from normal temperature to cold during use.	<b>5.1</b> Water pressure has dropped below minimum required.	<b>5.1.1</b> Wait until the water pressure resumes to normal.
<b>6</b> Cold indicator light on and low pressure indicator light flashing.	<b>6.1</b> Purge pin not placed correctly.	<b>6.1.1</b> Isolate the electricity supply. Remove remote pack cover and place purge pin on one pin only.
	<b>6.2</b> Low water pressure.	<b>6.2.1</b> Wait until the water pressure resumes to normal (low pressure indicator extinguishes).
		<b>6.2.2</b> Check if stop taps are fully open. Check if blockage in supply pipe.
<b>7</b> Pressure relief device has operated (water ejected from PRD tube).	<b>7.1</b> Blocked showerhead.	<b>7.1.1</b> Clean or replace blocked sprayplate in showerhead and then fit new PRD.
	<b>7.2</b> Twisted/blocked flexible shower hose.	<b>7.2.1</b> Check for free passage through hose. Replace the hose if necessary and fit new PRD.
	<b>7.3</b> Showerhead not removed while commissioning.	<b>7.3.1</b> Fit new PRD. Commission unit with showerhead removed.
	<b>7.4</b> Water pressure above specified maximum for unit (see rating label).	<b>7.4.1</b> Fit pressure reducing valve to inlet and then fit new PRD.

**Note:** Identify cause of operation before fitting new PRD unit.  
When fitting a new PRD, follow the commissioning procedure.

**It is advised all electrical maintenance/repairs to the shower should be carried out by a suitably qualified person.**

**In the unlikely event of unit failure other than detailed in the fault finding page, please contact Customer Service for advice.**



## Service Policy

In the event of a complaint occurring, the following procedure should be followed:

- 1 Telephone Customer Service on 0870 067 3333 (0845 762 6591 in Scotland and in Northern Ireland), having available the model number and power rating of the product, together with the date of purchase.
- 2 Triton Customer Service will be able to confirm whether the fault can be rectified by either the provision of a replacement part or a site visit from a qualified Triton service engineer.
- 3 If a service call is required the unit must be fully installed for the call to be booked and the date confirmed. In order to speed up your request, please have your postcode available when booking a service call.
- 4 It is essential that you or an appointed representative (who must be a person of 18 years of age or more) is present during the service engineer's visit and receipt of purchase is shown.
- 5 A charge will be made in the event of an aborted service call by you but not by us, or where a call under the terms of guarantee has been booked and the failure is not product related (i.e. scaling and furring, incorrect water pressure, pressure relief device operation, electrical installation faults).
- 6 If the product is no longer covered by the guarantee, a charge will be made for the site visit and for any parts supplied.
- 7 Service charges are based on the account being settled when work is complete, the engineer will then request payment for the invoice. If this is not made to the service engineer or settled within ten working days, an administration charge will be added.

## Replacement Parts Policy

**Availability:** It is the policy of Triton to maintain availability of parts for the current range of products for supply after the guarantee has expired. Stocks of spare parts will be maintained for the duration of the product's manufacture and for a period of five years thereafter.

In the event of a spare part not being available a substitute part will be supplied.

**Payment:** The following payment methods can be used to obtain spare parts:

- 1 By post, pre-payment of pro forma invoice by cheque or money order.
- 2 By telephone, quoting credit card (MasterCard or Visa) details.
- 3 By website order, [www.tritonshowers.co.uk](http://www.tritonshowers.co.uk)

Triton Showers  
Triton Road  
Nuneaton  
Warwickshire CV11 4NR

Triton is a division of Norcross Group (Holdings) Limited

## TRITON STANDARD GUARANTEE

Triton guarantee this product against all mechanical and electrical defects arising from faulty workmanship or materials for a period of two years for domestic use only, from the date of purchase, provided that it has been installed by a competent person in full accordance with the fitting instructions.

Any part found to be defective during this guarantee period we undertake to repair or replace at our option without charge so long as it has been properly maintained and operated in accordance with the operating instructions, and has not been subject to misuse or damage.

This product must not be taken apart, modified or repaired except by a person authorised by Triton. This guarantee applies only to products installed within the United Kingdom and does not apply to products used commercially. This guarantee does not affect your statutory rights.

### What is not covered:

- 1 Breakdown due to: *a)* use other than domestic use by you or your resident family; *b)* wilful act or neglect; *c)* any malfunction resulting from the incorrect use or quality of electricity, gas or water or incorrect setting of controls; *d)* faulty installation.
- 2 Repair costs for damage caused by foreign objects or substances.
- 3 Total loss of the product due to non-availability of parts.
- 4 Compensation for loss of use of the product or consequential loss of any kind.
- 5 Call out charges where no fault has been found with the appliance.
- 6 The cost of repair or replacement of pressure relief devices, showerheads, hoses, riser rails and/or wall brackets, isolating switches, electrical cable, fuses and/or circuit breakers or any other accessories installed at the same time.
- 7 The cost of routine maintenance, adjustments, overhaul modifications or loss or damage arising therefrom, including the cost of repairing damage, breakdown, malfunction caused by corrosion, furring, pipe scaling, limescale, system debris or frost.

**Customer Service:** ☎ 0870 067 3333

**Scottish and Northern Ireland  
Customer Service:** ☎ 0845 762 6591

**Trade Installer Hotline:** ☎ 0870 067 3767  
**Fax:** 0870 067 3334

[www.tritonshowers.co.uk](http://www.tritonshowers.co.uk)

**E mail:** [technical@tritonshowers.co.uk](mailto:technical@tritonshowers.co.uk)

**Extended Warranty AVAILABLE NOW. Call 0870 067 3333 for more details.**

TRITON reserve the right to change product specification without prior notice. E&OA. © TRITON SHOWERS 2008