



Electro-hydraulic actuators

SKB62... SKC62...
SKB60 SKC60

for valves with a 20 mm or 40 mm stroke

- **SK...62...:** Operating voltage AC 24 V, control signal DC 0...10 V, 4... 20 mA or 0 ... 1000 Ω , with spring-return function
- **SK...60:** as SK...62, but without spring-return function
- **SK...62U:** as SK...62, but UL-approved
- **SK...62UA:** as SK...62U, but with enhanced functions (choice of direction of operation, stroke limit control, sequence control with adjustable start point and operating range, and signal addition for operation of frost protection monitors, types QAF21... and QAF61...)
- **Positioning force 2800 N**
- **Choice of flow characteristic: equal-percentage or linear**
- **Position feedback**
- **Stroke calibration**
- **LED status indication**
- **Override control**
- **Manual adjuster and position indicator**
- **For direct mounting on valves; no adjustments required**
- **Additional functions with auxiliary switch, stem heater and mechanical stroke inverter (SKB... only)**
- **SK...62U and SK...62UA are UL-approved**

Application

For the operation of Siemens two-port and three-port valves, types VVF... and VXF... with a 20 mm or 40 mm stroke, as control and safety shut-off valves in heating, ventilation and air conditioning systems.

Types

SKB... with 20 mm stroke

Versions with standard electronics

Type	Operating voltage	Control signal	Spring-return		Positioning time		Enhanced function	
			Function	Time	Opening	Closing		
SKB62 SKB62U *	AC 24 V	DC 0 ... 10 V, 4 ... 20 mA or	Yes	15 s	120 s	15 s	No	
SKB60		0 ... 1000 Ω	No	--				
Version with enhanced electronics	SKB62UA *	AC 24 V	DC 0 ... 10 V, 4 ... 20 mA or	Yes	15 s	120 s	15 s	Direction of operation Stroke limit control Sequence control Signal addition
			0 ... 1000 Ω					

SKC... with 40 mm stroke

Versions with standard electronics

Type	Operating voltage	Control signal	Spring-return		Positioning time		Enhanced function	
			Function	Time	Opening	Closing		
SKC62 SKC62U *	AC 24 V	DC 0 ... 10 V, 4 ... 20 mA or	Yes	20 s	120 s	20 s	No	
SKC60		0 ... 1000 Ω	No	--				
Version with enhanced electronics	SKC62UA *	AC 24 V	DC 0 ... 10 V, 4 ... 20 mA or	Yes	20 s	120 s	20 s	Direction of operation Stroke limit control Sequence control Signal addition
			0 ... 1000 Ω					

* UL-approved versions

Accessories

Type	Description
ASC1.6	Auxiliary switch
ASZ6.5	Stem heater AC 24 V
ASK51	Mechanical stroke inverter (SKB... only)

Ordering

When ordering please specify the quantity, product name and type code.
Example: **1 actuator, type SKC62 and**
1 auxiliary switch ASC1.6

Delivery

The actuator, valve and accessories are supplied in separate packaging and not assembled prior to delivery.

Compatibility

Controllers

The actuators can be driven by all control systems which have an AC 24 V SELV/PELV supply and operate with DC 0 ... 10 V or 4 ... 20 mA signals.

Frost protection monitor

The added signals from the QAF21... and QAF61... require the use of SKB62UA and SKC62UA actuators.

Notes on special programming of the electronics are described under «Enhanced electronics» on pages 6 and 7.

Globe valves

The actuators are suitable for operation of the following Siemens two-port and three-port valves with a 20 mm or 40 mm stroke:

Valve	DN	PN	Data sheet
<i>Two-port valves VV... (control valves or safety shut-off valves):</i>			
VVF21... (Flange)	25 ... 100	6	4310
VVF31... (Flange)	25 ... 150	10	4320
VVF40... (Flange)	15 ... 150	16	4330
VVF41... (Flange)	50 ... 150	16	4340
VVF45... (Flange)	50 ... 150	16	4345
VVF52... (Flange)	15 ... 40	25	4373
VVF61... (Flange)	15 ... 150	40	4382
<i>Three-port valves VX... (control valves for mixing and distribution)</i>			
VXF21... (Flange)	25 ... 100	6	4410
VXF31... (Flange)	25 ... 150	10	4420
VXF40... (Flange)	15 ... 150	16	4430
VXF41... (Flange)	15 ... 150	16	4440
VXF61... (Flange)	15 ... 150	40	4482

For admissible differential pressures Δp_{\max} and closing pressures Δp_s , refer to the relevant valve data sheets.

Note Third-party valves with strokes between 6 and 20 mm (SKB...) and 12 ... 40 mm (SKC...) can be motorized, provided they have a «closed when de-energized» failsafe mechanism, and provided that the necessary mechanical coupling is available. We recommend that you contact your local Siemens office for the necessary information.

Technology

Principle of operation

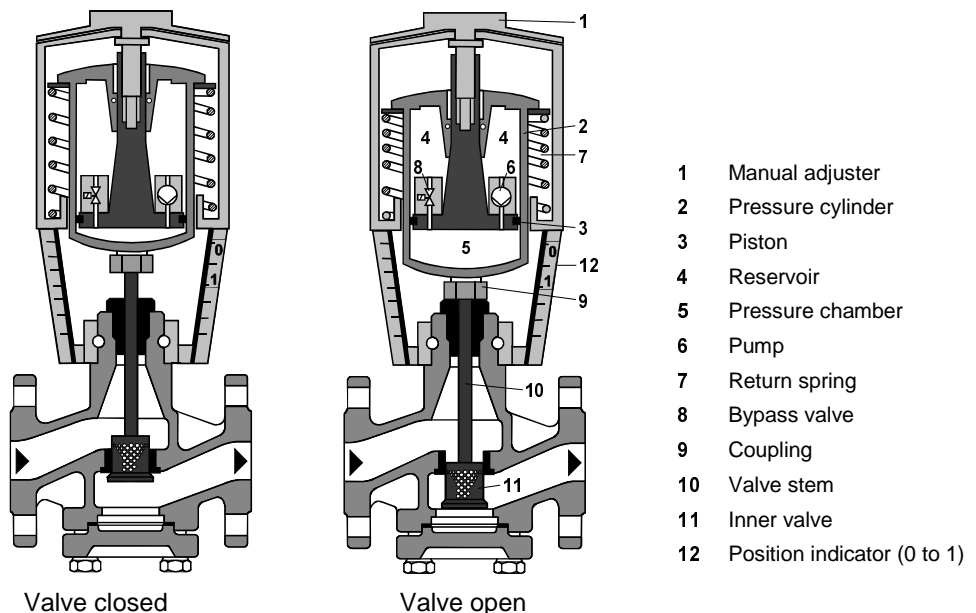

Signal input Y

- Increasing:** The pump (6) forces hydraulic oil from the reservoir (4) into the pressure chamber (5) thereby generating the stroke: the valve stem (10) is retracted and the valve plug opens (11).
- Decreasing:** The bypass valve (8) opens, allowing the hydraulic oil to flow back from the pressure chamber (5) into the reservoir (4) via the return spring (7). The valve stem (10) extends and the valve plug closes (11).
- Constant:** The actuator and valve hold the current stroke position.

Principles diagram

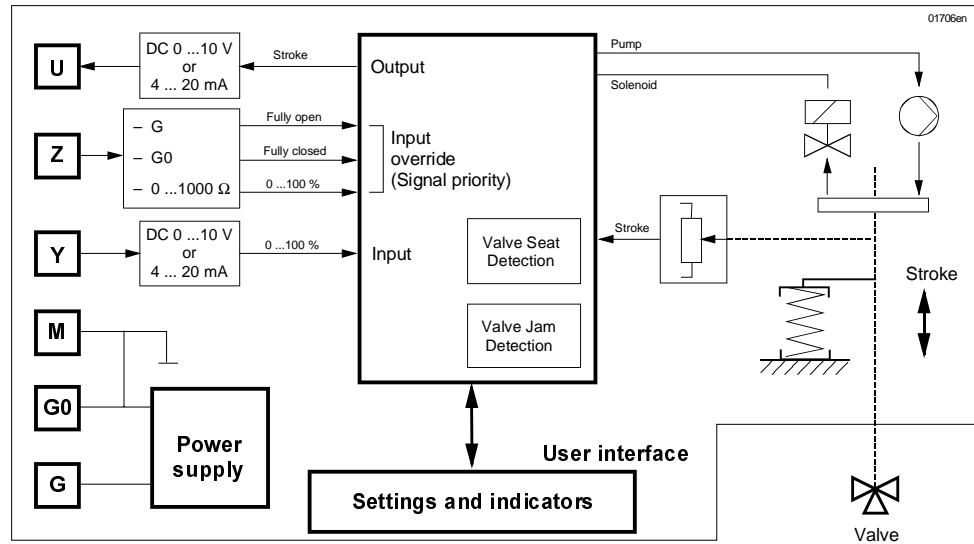

Spring-return function

All SK...62... actuators are factory-fitted with a spring-return function, so that if the control signal or power supply fails, the actuator will return to the «0%» stroke position. The SK...60 actuators do not have a spring-return function. In case of a power failure these actuators remain in their current stroke position.

Override control

The override control input (Z) has four modes of operation:

Valve fully opened	Valve fully closed
<ul style="list-style-type: none"> - Z-contact connected directly to G - Y-input has no effect 	<ul style="list-style-type: none"> - Z-contact connected directly to G0 - Y-input has no effect
Override with 0 ... 1000 Ω	Signal addition (SKB62UA and SKC62UA only)
<ul style="list-style-type: none"> - Z-contact connected to M via resistor R - Equal-percentage or linear characteristic - Starting position at 50 Ω / end position at 900 Ω - Y-input has no effect 	<ul style="list-style-type: none"> - Z-contact is connected to R of the frost protection monitor QAF21... or QAF61... - Valve stroke follows signals Y and R(Z)

Note The Z-modes shown assume the factory-setting «direct-acting».

Stroke calibration

To determine the stroke positions 0 and 100% in the valve, calibration is required when the valve/actuator are commissioned for the first time. For this purpose, the actuator must be mechanically connected to a Siemens valve (see «Compatibility») and must have a supply voltage of AC 24 V. The calibration procedure can be repeated as often as necessary.



Before starting calibration, ensure that the manual adjuster is set to «Automatic» in order to register the actual values.

There is a slot on the printed circuit boards of the actuators. To initiate the calibration procedure, the contacts inside this slot must be short-circuited (e.g. with a screwdriver).

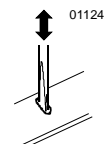

Automatic calibration proceeds as follows:

- Actuator runs to the «0 stroke» position (1), valve closes, green LED flashes.
- Actuator then runs to the «100 stroke» position (2), valve opens, green LED flashes.
- Measured values are stored.

The calibration procedure is finish, and the green LED now glows steadily (normal operation).

- The actuator now moves to the position defined by control signal Y or Z (3).
- Throughout this procedure, output U is inactive, i.e. the values only represent actual positions when the green LED stops flashing and remains on continuously.

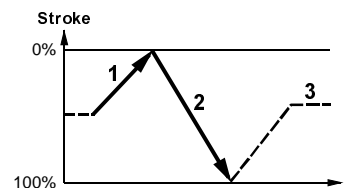

LED status indication

LED	Display	Function	Action
Green	On	<ul style="list-style-type: none"> • Normal operation 	Automatic operation, no problems
	Flashing	<ul style="list-style-type: none"> • Stroke calibration in progress 	Wait until calibration is complete (LED stops flashing)
Red	On	<ul style="list-style-type: none"> • Faulty stroke calibration • Internal error 	Check mounting Re-start stroke calibration (by short-circuiting calibration slot) Replace electronics
	Flashing	<ul style="list-style-type: none"> • Inner valve jammed 	Check the valve
Both	Off	<ul style="list-style-type: none"> • No power supply • Faulty electronics 	Check mains Replace electronics

Standard electronics

SKB62, SKC62
SKB60, SKC60
SKB62U, SKC62U

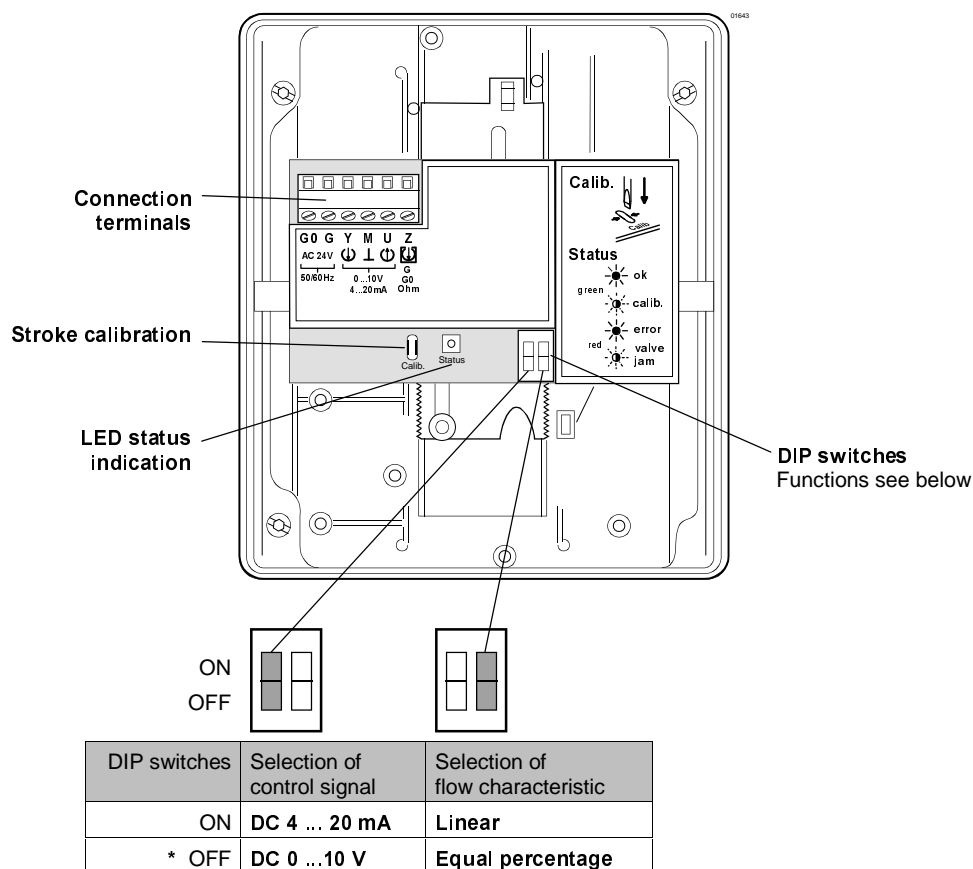

* Factory setting: all switches OFF

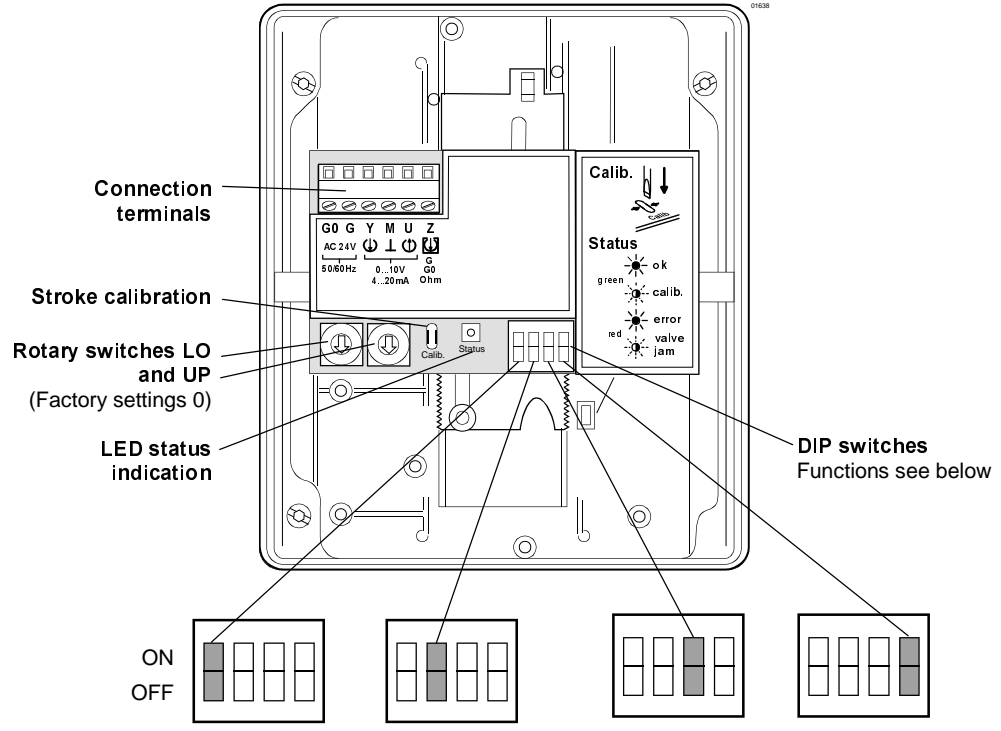

DIP switches	Select direction of operation	Sequence control or stroke limit control	Selection of control signal	Selection of flow characteristic
ON	Reverse-acting	Sequence control Signal addition QAF21... / QAF61...	DC 4 ... 20 mA	Linear
* OFF	Direct-acting	Stroke limit control	DC 0 ... 10 V	Equal percentage

* Factory setting: all switches OFF

Selecting the direction of operation

- With normally-closed valves, «direct-acting» means that with a signal input of 0 V, the valve closes (applies to all Siemens valves listed under «Compatibility» on page 3)
- With normally-open valves, «direct-acting» means that with a signal input of 0 V, the valve is open.

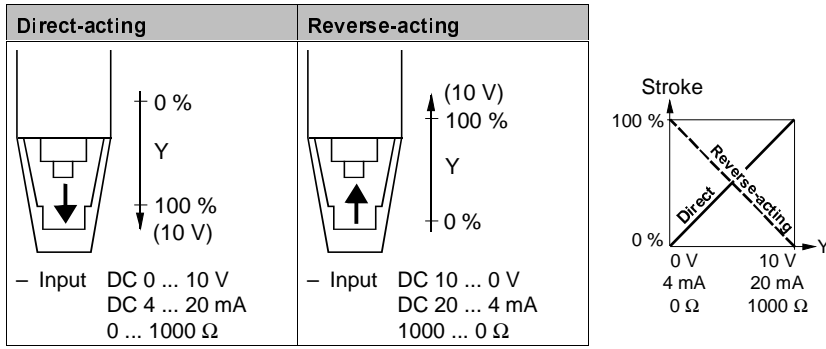

Note The mechanical spring-return function is not affected by the direction of operation selected.

Stroke limit control
and sequence control

Setting the stroke limit control

The rotary switches LO and UP can be used to apply an upper and lower limit to the stroke in increments of 3%, up to a maximum of 45%.

Position of LO	Lower stroke limit	Position of UP	Upper stroke limit
0	0%	0	100%
1	3%	1	97%
2	6%	2	94%
3	9%	3	91%
4	12%	4	88%
5	15%	5	85%
6	18%	6	82%
7	21%	7	79%
8	24%	8	76%
9	27%	9	73%
A	30%	A	70%
B	33%	B	67%
C	36%	C	64%
D	39%	D	61%
E	42%	E	58%
F	45%	F	55%

Setting the sequence control

The rotary switches LO and UP can be used to determine the starting point or the operating range of a sequence.

Position of LO	Starting point for sequence control	Position of UP	Operating range of sequence control
0	0 V	0	10 V
1	1 V	1	10 V *
2	2 V	2	10 V **
3	3 V	3	3 V ***
4	4 V	4	4 V
5	5 V	5	5 V
6	6 V	6	6 V
7	7 V	7	7 V
8	8 V	8	8 V
9	9 V	9	9 V
A	10 V	A	10 V
B	11 V	B	11 V
C	12 V	C	12 V
D	13 V	D	13 V
E	14 V	E	14 V
F	15 V	F	15 V

- * Operating range of QAF21... (see below)
- ** Operating range of QAF61... (see below)
- *** The smallest adjustment is 3 V; control with 0...30 V is only possible via Y.

Stroke control with
QAF21... / QAF61...
signal addition

Setting the signal addition

The operating range of the frost protection monitor (QAF21... or QAF61...) can be defined with rotary switches LO and UP.

Position of LO	Sequence control start point	Position of UP	QAF21... / QAF61... operating range
0		1	QAF21...
0		2	QAF61...

Accessories

ASC1.6 auxiliary switch

- Switching point 0 ... 5 % stroke

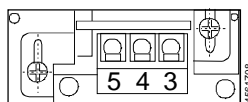

ASZ6.5 stem heater

- For media below 0°C
- Mount between valve and actuator

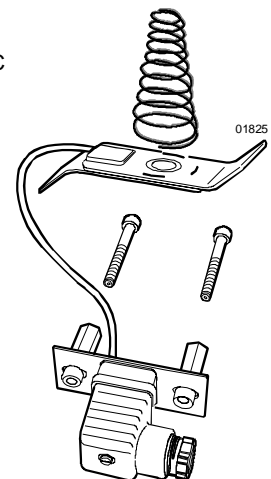

Engineering notes

The actuators must be electrically connected in accordance with local wiring regulations and with the wiring diagram on page 12.

Regulations and requirements designed to ensure the safety of people and property must be observed at all times.

The ASZ6.5 stem heater has a heat output of 30 VA and is required to keep the valve stem free of ice in the cooling range 0 °C ... -25 °C. In this case, in order to ensure adequate air circulation, the actuator bracket and the valve stem must not be insulated. Physical contact with unprotected hot components can cause burns. Failure to observe the above advice can result in accidents or fire.

The admissible temperatures (see «Application» and «Technical data») must be observed.

Mounting instructions

Orientation

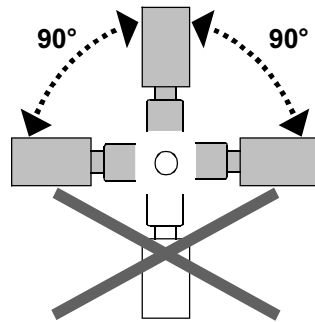

Instructions for fitting the actuator to the valve are enclosed in the actuator packaging. The instructions for accessories are enclosed with the accessories themselves.

Commissioning notes

When commissioning the system, check the wiring and functions.

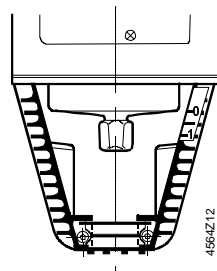

Cylinder with valve stem connector fully retracted

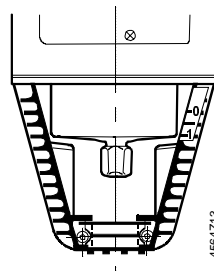

Cylinder with valve stem connector fully extended

Automatic operation

For automatic operation, the crank (2) on the manual adjustment knob (1) must be engaged. If not engaged, turn the crank counter-clockwise until the display window (3) neither shows the scale (4) nor the crank engagement bar.

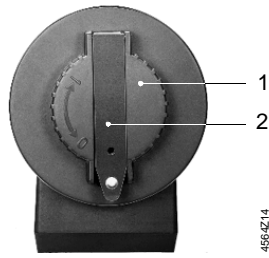

Engaged crank (2) on the manual adjustment knob (1)

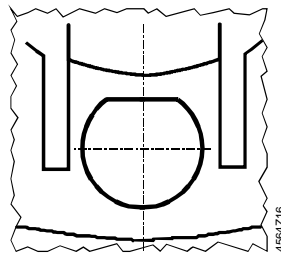

Display window with invisible scale dial and crank engagement bar

Manual operation

For manual operation, swing out the crank (2) so that the display window (3) becomes visible. By rotating the crank or the manual adjustment knob (1), the display window shows the engagement bar and/or the scale dial with stroke indication.

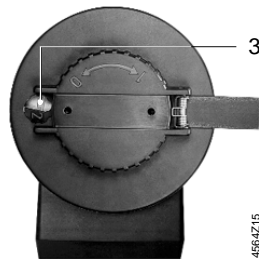

Swung-out crank, display window (3)

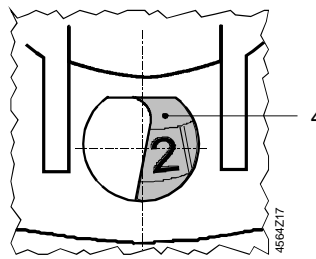

Display window with scale dial (4) and stroke indication



The manual adjuster must be rotated counterclockwise to the end stop. This causes the Siemens valves, types VVF... and VXF... to close (stroke = 0%).

Maintenance

- When servicing the valve:
Switch OFF the pump and power supply, close the main shut-off valves in the pipework, release pressure in the pipes and allow them to cool down completely. If necessary, disconnect electrical connections from terminals.
- The valve must be re-commissioned only with the actuator correctly assembled.
- The actuators and valves require no maintenance.

Disposal



The actuator includes electrical and electronic components and must not be disposed of as domestic waste.

Current local legislation must be observed.

Warranty

The application-specific technical data is valid for Siemens actuators used in conjunction with the Siemens valves listed under «Compatibility» (sub-heading «Globe valves»).

Before using these actuators with third-party valves, written approval must be obtained from Siemens Building Technologies. A failure to obtain this approval invalidates any guarantee.

Technical data

		SKB...	SKC...	
Power supply	Operating voltage (SELV, PELV)	AC 24 V -20 % / +30 %		
	Frequency	50 or 60 Hz		
	Power consumption			
	SK...62...	17 VA / 12 W	28 VA / 20 W	
SK...60	13 VA / 10 W	24 VA / 18 W		
	External supply cable fuse	Min. 1 A slow blow, Max. 10 A slow blow	Min. 1.6 A slow blow, Max. 10 A slow blow	
Operating data	Type of control (proportional)	DC 0 ... 10 V, DC 4 ... 20 mA or 0 ... 1000 Ω		
	Positioning time at 50 Hz	120 s (opening) 15 s (closing)	120 s (opening) 20 s (closing)	
	Spring-return function	to DIN 32730		
	Spring-return time (closing)	15 s	20 s	
	Nominal stroke	20 mm	40 mm	
	Positioning force	2800 N		
	Flow characteristic	Equal percentage / linear can be selected *		
	Maximum admissible temperature of medium in the connected valve	-25 ... +220 °C < 0 °C: type ASZ6.5 stem heater required > 220 ... +350 °C: use special extension on valve		
	Signal inputs	Terminal Y		
		Voltage	DC 0 ... 10 (30) V	
	Input impedance	100 kΩ		
	Current	DC 4 ... 20 mA		
	Input impedance	240 Ω		
	Signal resolution	<1 %		
	Hysteresis	1 %		
	Terminal Z			
	Resistance	0 ... 1000 Ω		
	Override control functions			
	Z not connected	No function (priority at Terminal Y)		
	Z connected directly to G	Max. stroke 100 %		
	Z connected directly to G0	Min. stroke 0 %		
	Z connected to M via 0 ... 1000 Ω	Stroke proportional to R		
Signal outputs	Terminal U			
	Voltage	DC 0 ... 9.8 V ±2 %		
	Load impedance	>500 Ω		
	Current	DC 4 ... 19.6 mA ±2 %		
	Load impedance	<500 Ω		

* in conjunction with valves listed under «Compatibility» on page 3

		SKB...	SKC...
Industry standards	Meets the requirements for CE marking in EMC Directive Low Voltage Directive	89/336/EEC 73/23/EEC	
	Electromagnetic compatibility Emitted interference Interference immunity	EN 61000-6-3 Residential EN 61000-6-2 Industrial	
	Product standards for automatic electric controls	EN 60730-2-14	
	C-tick	N474	
	Protection standard	IP54 to EN 60529	
	Protection class	III to EN 60730	
	UL approval	UL 873 (SK...U, SK...UA)	
	Dimensions / Weight	Dimensions	See «Dimensions»
Cable glands		4 x Pg 11 (SK...62, SK...60) 4 x Pg 16 (SK...62U, SK...62UA)	
Weight (including packaging)		8.60 kg	10 kg
Housing	Actuator housing and bracket	Die-cast aluminum	
	Housing box and manual adjuster	Plastic	

SK...62UA enhanced functions

Direction of operation	Direct acting / reverse acting	DC 0 ... 10 V / DC 10 ... 0 V DC 4 ... 20 mA / DC 20 ... 4 mA 0 ... 1000 Ω / 1000 ... 0 Ω	
Stroke limit control	Range of lower limit	0 ... 45 % adjustable	
	Range of upper limit	100 ... 55 % adjustable	
Sequence control	Terminal Y		
	Starting point of sequence Operating range of sequence	0 ... 15 V adjustable 3 ... 15 V adjustable	
Signal addition	Z connected to R of		
	Frost protection monitor QAF21... Frost protection monitor QAF61...	0 ... 1000 Ω, added to Y signal DC 1,6 V, added to Y signal	

Accessories

ASC1.6 auxiliary switch	Switching capacity of auxiliary switch	AC 24 V, 10 mA ... 4 (2) A	
ASZ6.5 stem heater	Operating voltage	AC 24 V ±20 %	
	Power consumption (heat output)	30 VA	

General ambient conditions

	Operation IEC 721-3-3	Transport IEC 721-3-2	Storage IEC 721-3-1
Environmental conditions	Class 3K5	Class 2K3	Class 1K3
Temperature	-15 ... +55 °C	-30 ... +65 °C	-15 ... +55 °C
Humidity	5 ... 95 %rh	< 95 %rh	0 ... 95 %rh

Connection diagram

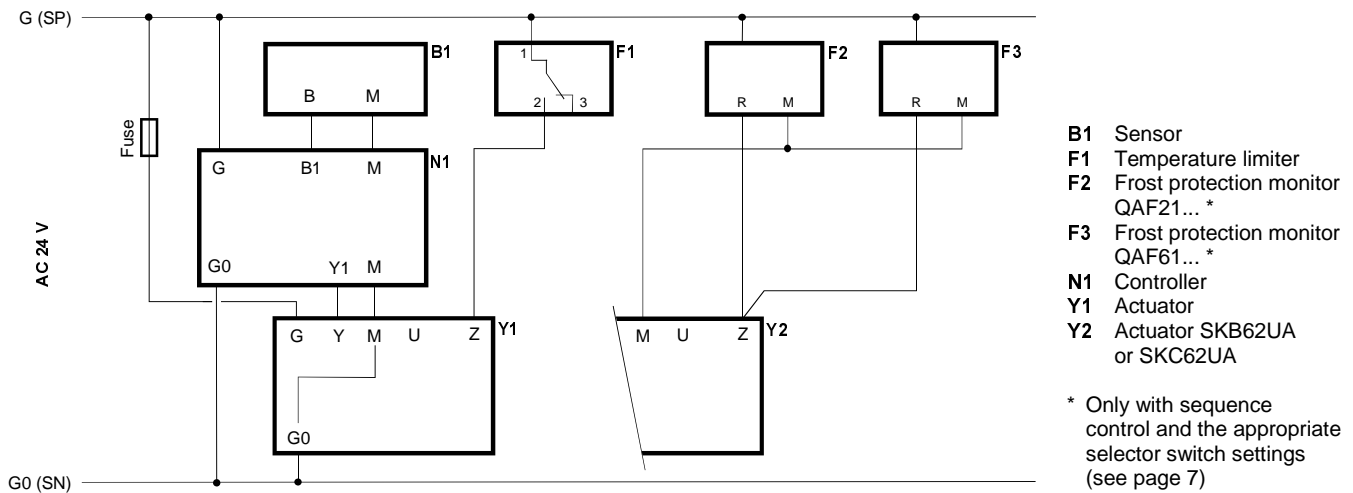

Connection terminals

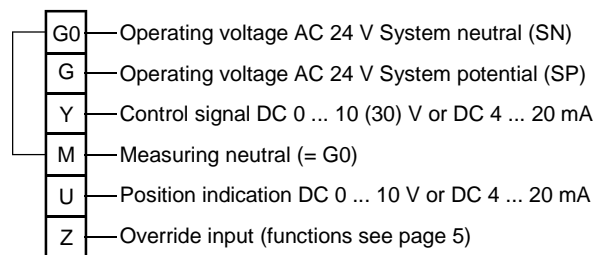

ASC1.6 auxiliary switch

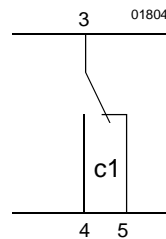

Dimensions

All dimensions in mm

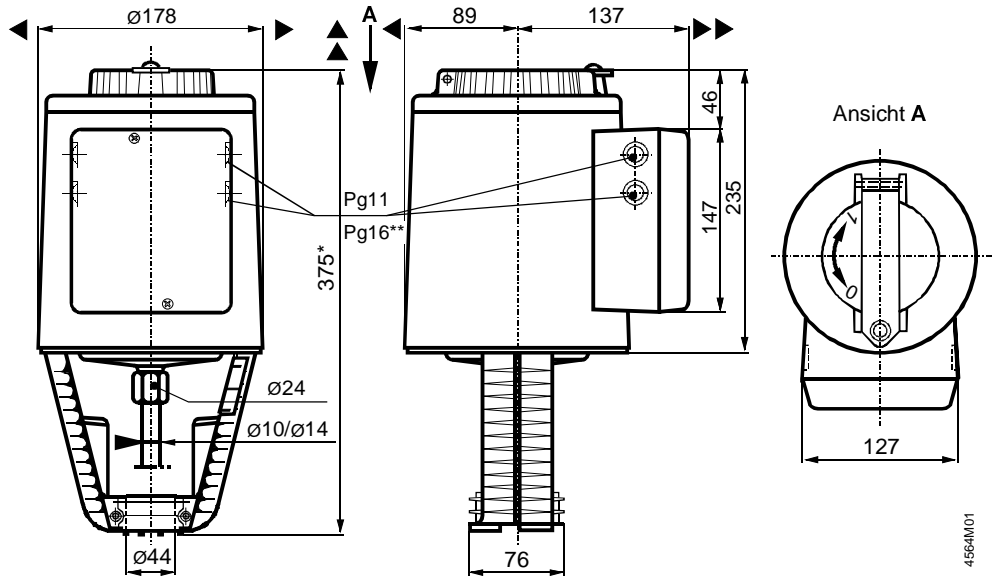

* Height of actuator from valve plate without stroke inverter ASK51 = 300 mm
 Height of actuator from valve plate with stroke inverter ASK51 = 357 mm

** The hole diameter on the SK...62U... actuators corresponds to the Pg16 gland.

▲ = > 100 mm Minimum clearance from ceiling or wall for mounting, connection, operation, maintenance
 ▲▲ = > 200 mm etc.

ASK51 stroke inverter

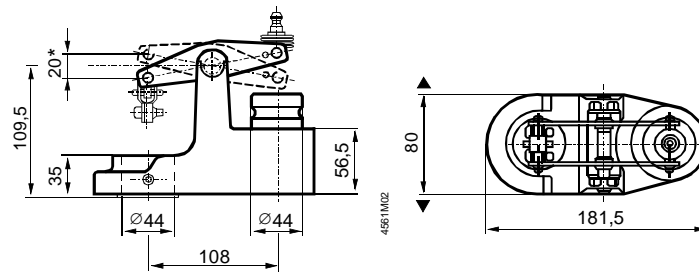

* Maximum stroke = 20 mm

