

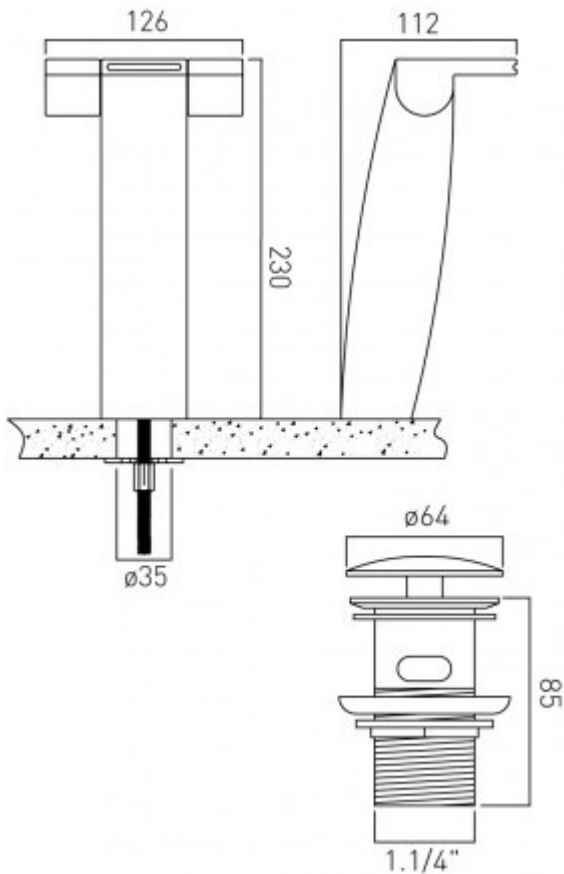

technical drawing



description:

extended mono basin mixer
deck mounted
smooth bodied
with clic-clac waste
1/4 turn ceramic disc valves
cold ceramic cartridge SUM-100/VALVE-CL
hot ceramic cartridge SUM-100/VALVE-HT
2 x 1/2" x 400mm flexipipe connections
deck mount drill hole diameter 35mm

finishes:

chrome

minimum operating pressure: 0.2 bar LP

Eco flow regulator: flow regulator fitted as standard

guarantee:

12 year guarantee

VADO wedmore road cheddar somerset england bs27 3eb

tel 01934 744466 fax 01934 744345 sales@vado-uk.com www.vado-uk.com