

mira
everclear

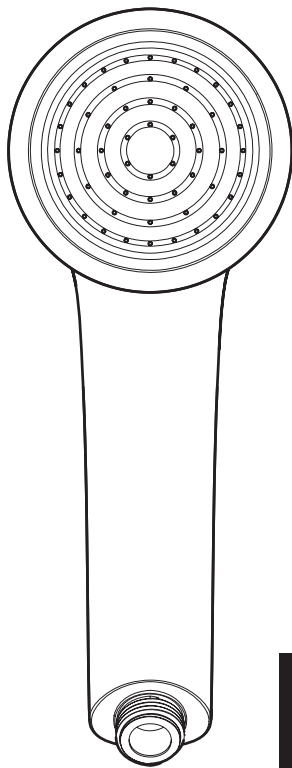

**MIRA EVERCLEAR
ANTI-LIMESCALE
HANDSET**

1616.030 & 1616.031

1616.034 & 1616.035

Accessory Pack

Installation and User Guide

THESE INSTRUCTIONS ARE TO BE LEFT WITH THE USER

Introduction

The Mira Everclear is a single mode handset. It is suitable for most mixer showers and for electric showers over 9kW.

This Handset has been specifically designed for use in hard water areas. The design incorporates an automatic self drain action and pins to resist and clear lime scale build up.

The face of the handset is cleared with pins coming through the spray plate to stop the build up of lime scale. The pressure of the water moves the spray plate over the pins which enables the holes in the handset to be automatically cleaned.

The Mira Everclear shower handset is available in white or chrome.

System Applications

- Instantaneous gas heated systems
- Gravity-fed systems
- Mains pressure systems
- Pumped systems
- Electric showers (over 9kW)

Additional Features

- Automatic Descale
- Automatic Handset Draindown
- Additional Manual Descale (if required)
- High and Low force spray plate

Alternative Nozzles

The showerhead has been fitted with low capacity spray unit, which is suitable for a pressure of 0.06 – 0.5 bar (0.6 – 5 m head). They are suitable for most shower installations, but for high pressure installations the spray force may be too powerful for comfortable showering. In high-pressure installations, such as gas water heaters that require a higher flow rate to operate correctly, we recommend that the high capacity spray unit be fitted.

The high capacity spray unit is also included in the pack.

Refer to the Maintenance section for fitting instructions.

Specification

Minimum maintained pressure:

With low capacity spray unit fitted (as supplied): 5 kPa (0.05 bar).

With high capacity spray unit fitted: 10 kPa (0.1 bar).

Maximum maintained pressure: 500 kPa (5.0 bar).

Connections: ½" BSP Male

Warning! Exceeding the stated maximum maintained pressure could result in excessive spray force and possible damage to the handset.

Dimensions

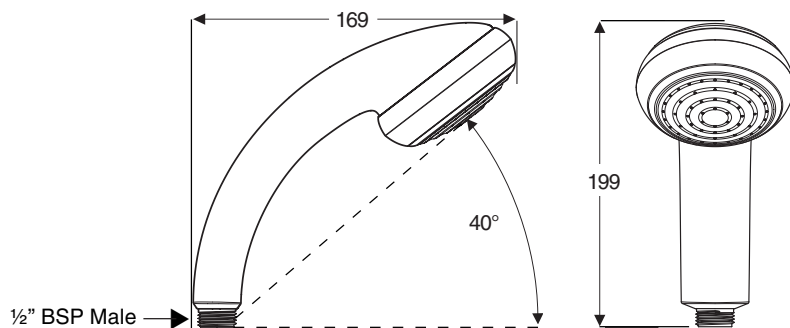

All dimensions are nominal and in millimetres

Installation

Installation

1. Unscrew the existing handset from the flexible shower hose.

Note! The hose and handset may have water in them.

2. Screw the handset into the flexible shower hose. If there is a hose washer, be careful to retain it.

Caution! Do not overtighten.

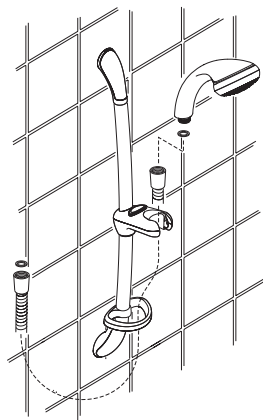

Operation

Spray Settings

The Everclear handset has three operation modes:

1. The flow of water automatically pushes the spray plate forward, sealing it against the retainer and allowing showering to start.

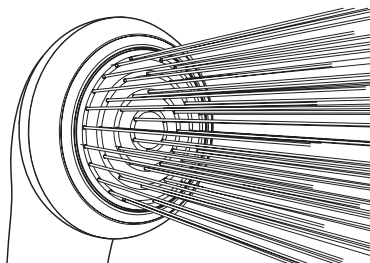

2. Turning off the flow of water automatically allows the spray plate to retract to the rest position, causing a series of pins to clear any scale from the holes. Water left in the shower head will drain away.

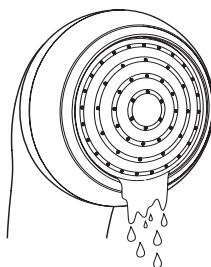

3. If the spray plate should become stuck, it can be pressed further inwards by the user, this will clear any additional scale from the holes. Once released, it will return to the rest position.

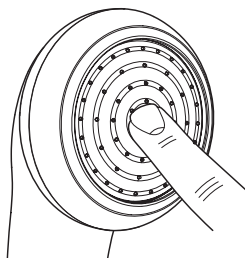

Maintenance

To clean or replace the Spray Unit:

1. Unclip and pull off the shroud.
2. Unscrew the retainer in an anticlockwise direction.
3. Remove the spray unit.
4. If cleaning remove any debris/scale with a stiff brush and wash out.
5. Ensure that the profile seal and outer spring are located into the holder.
6. Refit or renew the spray unit, (ensure the spray plate seal is fitted).
7. Screw in the retainer in a clockwise direction.
8. Push on and snap the shroud into place.

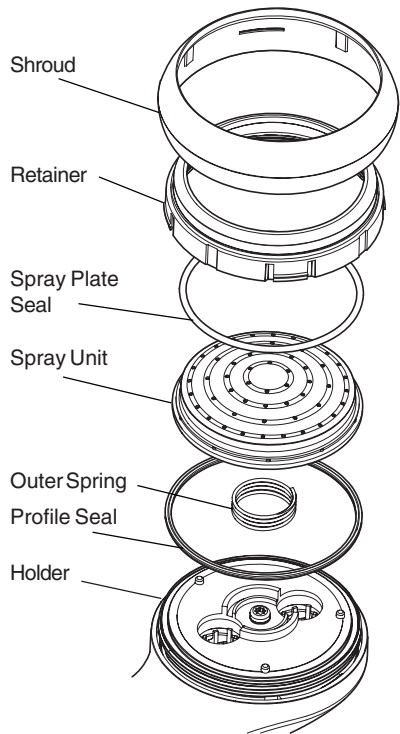

Spares

1616.038	Seal and Spring Pack
1616.039	Shroud White
1616.040	Shroud Chrome
1616.041	Retainer White
1616.042	Retainer Light Grey
1616.043	Spray Unit LC White
1616.044	Spray Unit LC Light Grey
1616.045	Spray Unit HC White
1616.046	Spray Unit HC Light Grey
1616.047	Everclear Handset White
1616.048	Everclear Handset Chrome

Spares

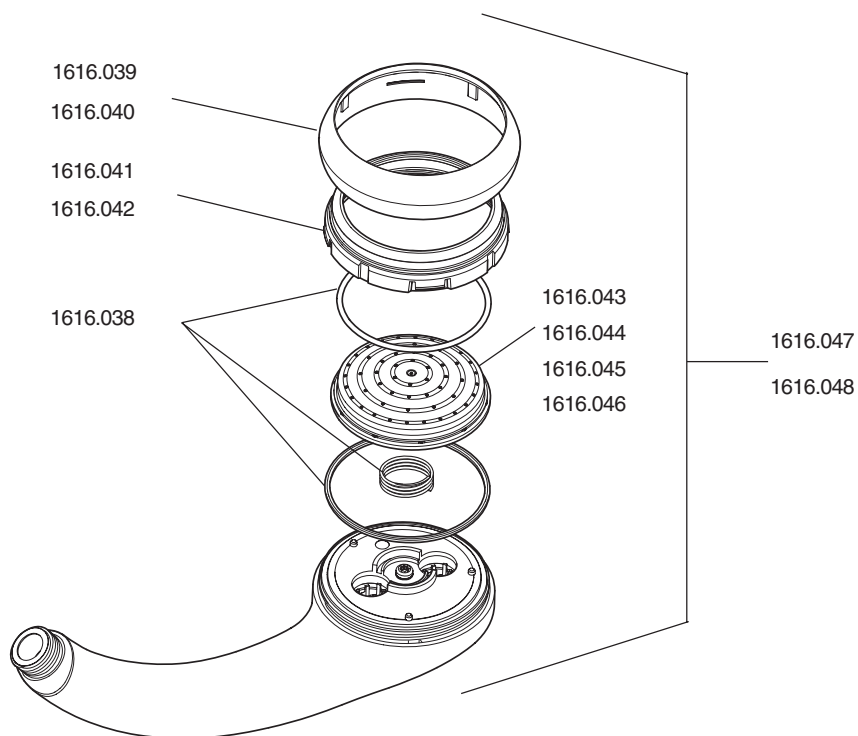

Customer Service

Guarantee (Accessories)

Mira Showers guarantees this product against any defect of materials or workmanship for one year from the date of purchase.

Within the guarantee period we will resolve defects, free of charge, by repair or replacement as we may choose.

Not covered by this guarantee:

- Damage or defects arising from incorrect installation, improper use or lack of maintenance, including build-up of limescale.
- Damage or defects if the product is taken apart, repaired or modified by any person not authorised by Mira Showers or our approved agents.

Proof of Purchase will be required to support any guarantee claims.

This guarantee is in addition to your statutory and other legal rights.

Our Customer Services Team is comprehensively trained to provide every assistance you may need: help and advice, spare parts or a service visit.

As part of our quality and training programme calls may be recorded or monitored.

Spare Parts

We maintain an extensive stock of spares, which can be purchased from approved stockists or merchants (locations on request) or direct from Customer Services.

Spares direct will normally be despatched within two working days. Payment can be made by Visa or Mastercard at the time of ordering. Should payment by cheque be preferred a pro-forma invoice will be sent.

Note! In the interests of safety, spares requiring exposure to mains voltages can only be sent to competent persons.

Service

Our Service Force is available to provide a quality service at a reasonable cost. You will have the assurance of a Mira trained engineer/agent, genuine Mira spares, and a 12 month guarantee on the repair.

To contact us

England, Scotland & Wales

Mira Showers Customer Services

Telephone: 0870 241 0888 8:30 am to 5:00 pm

Working days (4:30 pm Friday)

8:30 am to 12.30 pm Saturday

E-mail: technical@mirashowers.com

Fax: 01242 282595

By Post: Cromwell Road
Cheltenham
Gloucester
GL52 5EP

Northern Ireland

Wm H Leech & Son Ltd

Telephone: 028 9044 9257 – Mon to Fri 9 am-5pm

Fax: 028 9044 9234 – 24 hours

Post: Maryland Industrial Estate

Ballygowan Road
Moneyreagh, Co Down
BT23 6BL

Republic of Ireland

Modern Plant Ltd

Telephone: Dublin 01 4591344 – Monday to Friday
9am to 5pm

Fax: Dublin 01 4592329 – 24 hours

Post: Otter House

Naas Road
Clondalkin
Dublin 22

Mira Showers
Kohler Mira Ltd
Cromwell Road,
Cheltenham GL52 5EP.

Mira is a registered trade mark.
The company reserves the right to alter
product specifications without notice.

www.mirashowers.com



FM 14648

mira
SHOWERS

1059385-W-2-A

© Kohler Mira Limited, February 2006

prices and delivery to your door visit MyTub Ltd - www.mytub.co.uk - info@mytub.co.uk 0844 5