

**RAIN / WATER / LEAK DETECTOR**

**EW..**

<p>■ Detects conductive non corrosive liquid/water in plant rooms, boiler houses, under floors, roofs etc. <b>DO NOT</b> use with combustible liquids ie fuels. AC sensor excitation is used for reliable operation which eliminates the sensor degradation problems found with DC systems.</p>		<p>Volt free contacts</p> <p>Max ambient 70°C</p> <p>Adjustable sensitivity</p> <p>LED indication - light ON when the sensor is wet.</p>
---	--	--

Type	Unit	Supply ± 15%	230 VAC SPDT	Power Consumption	EW-01	Maximum No of Sensors EW-03	EW-06	Mounting	Enclosure
<b>EW-230</b>	Switch unit	230VAC	10(3)A	<2.5 VA	10 in parallel	200m	6	Din Rail	IP00
<b>EW-24</b>	Switch unit	24VAC	10(3)A	<1.4 VA	10 in parallel	200m	6	Din Rail	IP00
					Max cable length from the switch unit 200m				
<b>EW-01</b>	Probe Sensor	For use with above switch unit		2 wire	Box can be fitted in various locations				IP40
<b>EW-03</b>	Cable Sensor	For use with above switch unit		2 wire	3mm dia (Max 200m)	<b>ORDER PER METRE</b>		IP00	
<b>EW-06</b>	Rain Sensor	For use with above switch unit		4 wire	2 sensor & 2 heater wires 24VAC 1 watt (24VAC Transformer Available)			IP65	

**DIMENSIONS:**

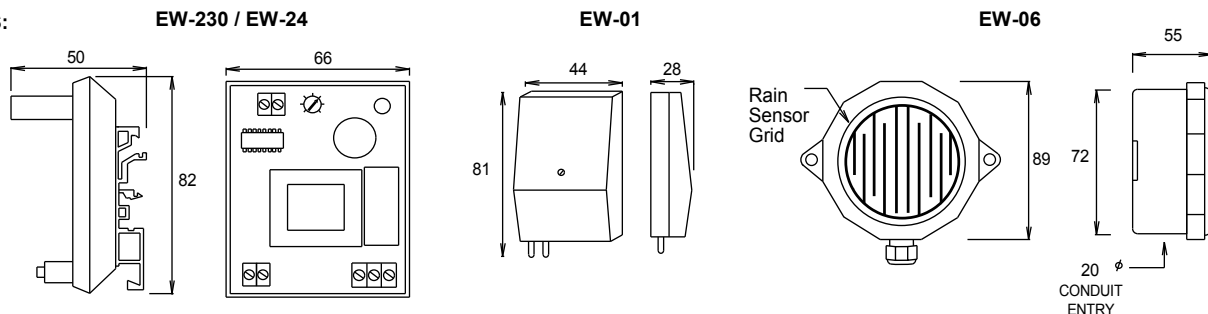

**ACCESSORIES:** **EE-M1T** Enclosure for EW-230 and EW-24 Dims : 125 H x 75 W x 75 D IP65 Enclosure Flammability UL94-V2

**WIRING:**

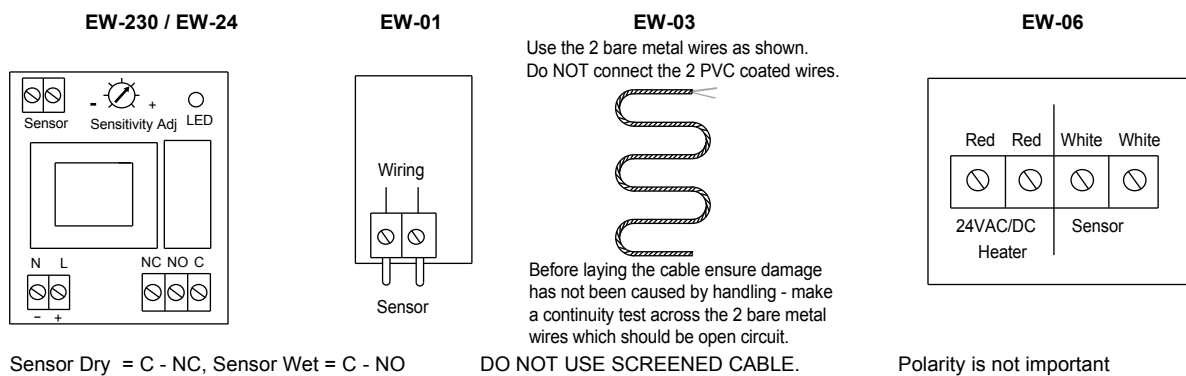

**INSTALLATION:**

- Terminals 0.5-2.5mm<sup>2</sup> Max combined length 200m including sensor cable. Sensitivity may need reducing with long runs. **DO NOT USE SCREENED CABLE. SENSOR CABLE MAY BE EXTENDED USING STANDARD PVC CABLE 7/0.2mm**
- EW-230/24** With power on and sensor connected, adjust sensitivity until LED is on, then turn back until LED just switches off. Short circuit the sensor at the furthest point from the switching unit. The LED and relay should switch on. To short circuit the sensor, press wet fingers or tin foil on to the sensor.
  - EW-01** The switch operates when the liquid touches both probes.
  - EW-03** The cable senses at any point along its entire length. Dirt on the cable can affect the switching. Fix the cable into position using plastic clips. Separate the two bare metal wires & connect them to the switching unit via standard 2 core unshielded PVC cable. **DO NOT** connect the 2 sensor PVC coated wires to the switching unit. Insulate any metallic parts before laying the sensor cable.
  - EW-06** The heater can be used to dry the surface after rainfall and to prevent false alarms when dew forms. Mount the unit at approx 45° to allow rain to fall off. Keep the sensor grid clean and protect from birds.