

customer/technical services

For any technical or installation queries please contact Vado on 01934 745163.

guarantee

This product is guaranteed against manufacturing defects from the date of purchase until the expiry of the relevant guarantee period shown below.

The guarantee is only valid if:-

1. The product has been installed, used and maintained in accordance with Vado's instructions and subjected to normal use only.
2. The defect is not due to use of an unsuitable or inadequate water or power supply.
3. The defect is not due to accident, misuse, neglect or repair other than by Vado or Vado authorised agents or damage caused by foreign objects or substances.
4. We have received from you the completed Guarantee Registration Form. Vado accepts no responsibility for any forms lost in the post and returns by registered means is therefore recommended.

Under this guarantee (which is non-transferable) Vado will, at its option, repair or replace free of charge any product (or replacement part) found to be defective. The guarantee does not extend to any consequential loss or damage. After repair or replacement the relevant guarantee period will be calculated from the original date of purchase.

The relevant guarantee periods are:-

1. Twelve years on chrome finish products.
2. Three years on all other products with the exception of Stuart Turner Pumps which carry a 2 year Guarantee on Monsoon Range and 1 Year Guarantee on Showermate Range.

All claims under the guarantee must be submitted in writing to the person who supplied the product to you and must be received no later than the last day of the relevant guarantee period. All claims must be accompanied by proof of purchase (sales receipt or delivery note).

Vado operates a policy of continuous product development and therefore reserves the right to change the product, packaging and documentation specifications without notice.

This guarantee is in addition to and does not affect your statutory rights as a consumer.

Vado

Wedmore Road, Cheddar, Somerset, England BS27 3EB
tel 01934 744466. fax 01934 744345
technical@vado-uk.com
www.vado-uk.com

GUARANTEE REGISTRATION

NAME				
ADDRESS				
	POSTCODE			
RETAILER				
ADDRESS				
	POSTCODE			
PURCHASE DATE	ARTICLE NUMBER	(SEE BOX)		
PRODUCT DESCRIPTION				
WHO INSTALLED THE PRODUCT?	RETAILER	PLUMBER	BUILDER	SELF
FOR VADO USE				



installation & maintenance instructions

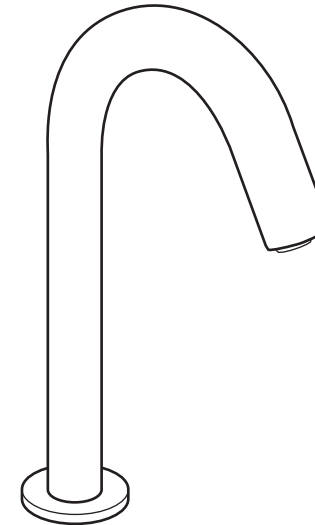

dspout

mono basin filler with infrared sensor

please leave these instructions with the customer

important - please read

Please read these instructions carefully before starting installation and keep for future reference.

Remove all packaging and check the product for missing parts or damage before starting installation.

Any alterations made to this product and fittings may infringe water and electrical regulations and will invalidate the guarantee.

Please note if installing in an enclosed environment, access should be left for servicing and maintenance. No costs relating to inadequate access can be accepted.

We strongly recommend that you use a qualified and registered plumber and electrician.

Plumbing Connections

The installation must comply with all Local/National Water Supply Authority Regulations/Byelaws and Building and Plumbing (UK:BS6700) Regulations.

Electrical Connections

All electrical connections should be carried out by a qualified electrician.

The installation must comply with current NICEIC regulations and to the requirements of BS7671 (Requirements for electrical installations).

Please ensure that all exposed metal is supplementary bonded.

care of the mixer

Our products are finished to the highest standard and due care needs to be taken to ensure their looks are retained.

We recommend cleaning all products with a soft damp cloth ONLY and advise strongly against the use of ALL cleaning products i.e. powders and liquids.

If the above instructions are not followed this will invalidate your guarantee in the event of a problem occurring.

maintenance

The inlet connection contains a filter, should you need to clean the filter, remove the inlet connection to the control box. Pull out the filter and clean under running water.

Replace the filter and inlet pipe.

troubleshooting

Description	Cause	Treatment
No water out	The batter is exhausted	Change the battery
	Water supply cut off	Check supply
	Dirt in the filter	Clean the filter
	Water pressure to low	Raise the pressure
Water will not turn off	Dirt on the sensor window	Clean the sensor
Too little water flow	Water supply is turned down	Adjust water supply
	The filter is too dirty	Clean the filter
	Water pressure is too low	Raise the pressure
Too much water flow	Water pressure is too high	Adjust pressure
Short cycles of battery	Incorrect batteries	Change to 4AA Alkaline batteries
The indicator light is not on	The light is broken	Change the light or circuit board
	The circuit board is wet or signal line is wet	Dry out
	The battery is exhausted	Change the battery
	Poor connection of battery	Check battery connections

disposal - please read

Waste electrical and electronic equipment (WEEE)

The wheeled bin symbol means the product is covered by the European Directive 2002/96/EC.

DO NOT dispose of this unit with normal household waste, take to a local authority recycling centre.



installation

⚠ Warning! Please check for any hidden cables and pipes before drilling holes in the wall.

Using suitable wall fixings for your wall (fittings supplied are for solid walls). Attached the control box in a suitable position under the basin making sure the flexible pipe from the tap will reach (Fig 1).

Connect the flexible pipe from the tap. Slide the clamp over the pipe, push the pipe over the connection on the bottom outlet marked 'Water Out'. Squeeze the two tabs on the clamp and slide up to the end of the pipe, release to secure in position.

Connect the water supply (flexible pipe shown) to the side connection marked 'Water In' (Fig 2).

Line up the groove on the 4 pin connector and push into the plug on the underside of the box, tighten the knurled ring to secure in place. Push the DC power jack coming from the transformer (supplied in box) into the socket on the side of the box (Fig 3).

Turn on the water and test.

Commissioning.

At point of commissioning hold down the red Reset button for 3 seconds and wait for 20 seconds before the sensor range can be reset, enabling the sensor to learn the IR distance to the sink (Fig 3).

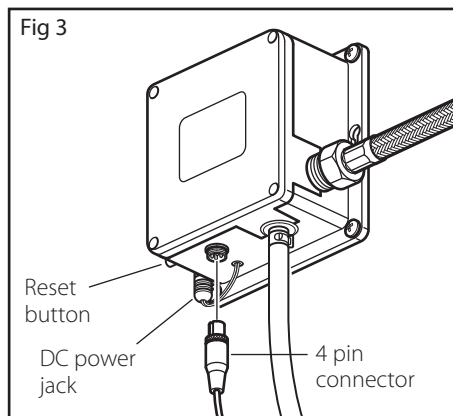
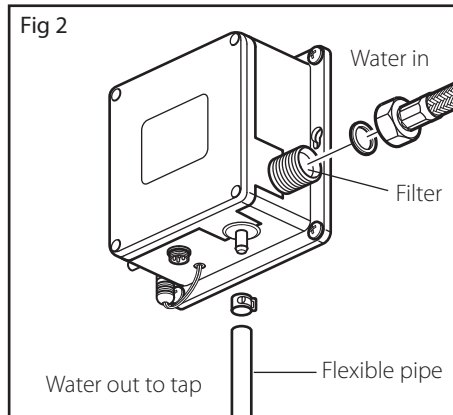
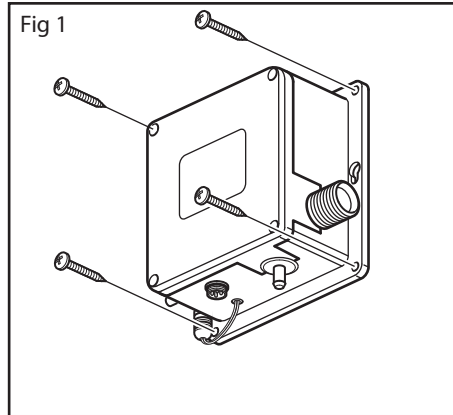

dimensions

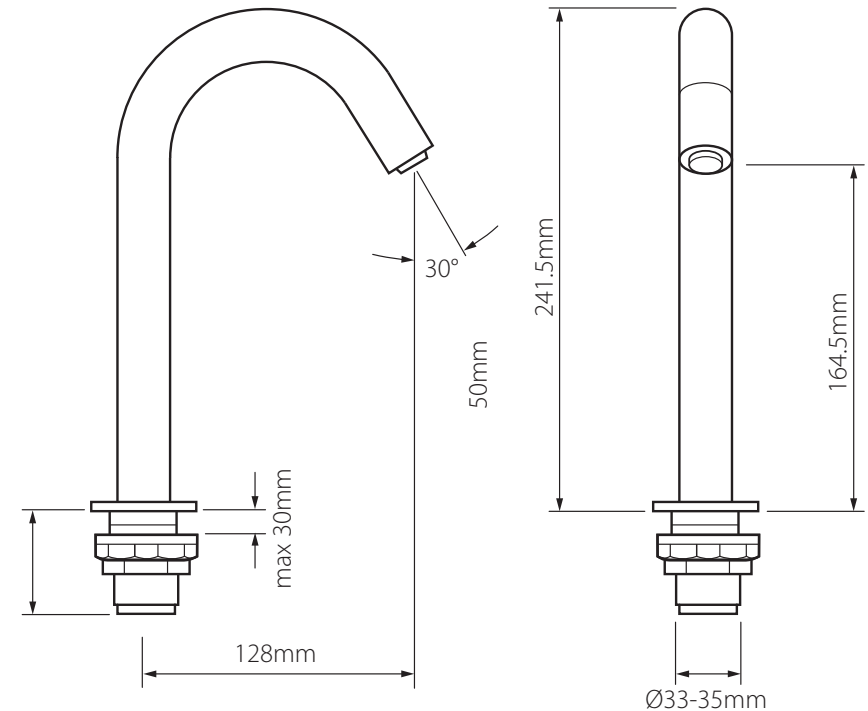

Operating Specifications

Operating Pressure:
Minimum operating pressure 0.5 bar
Maximum operating pressure 5 bar

electrical connection

Mains electrical connection

Connect the transformer to ~230V 50 Hz AC mains supply with a fused switch outside of the bathroom.

The mains cable can be connected to a 3 or 5 amp plug if required using the following connections.

Brown - (L) Live
Blue - (N) Neutral

Note: If using a plug and socket the socket must not be installed within the bathroom.

tap installation

Tap installation

Note: Please do not install this product opposite or near any reflective surfaces as this may lead to false or permanent activation.

Make sure that the rubber washer is in place at the base of the tap.

Push the flexible pipe and control cable down through the hole and position the mixer on the basin. From the underside of the basin slide the rubber washer and nut over the flexible pipe and onto the threaded tube and tighten.

CAUTION: Do not over tighten the nut as this may damage the basin.

Connect the tap to the 'water out' connection on the bottom of the control box, when installed.

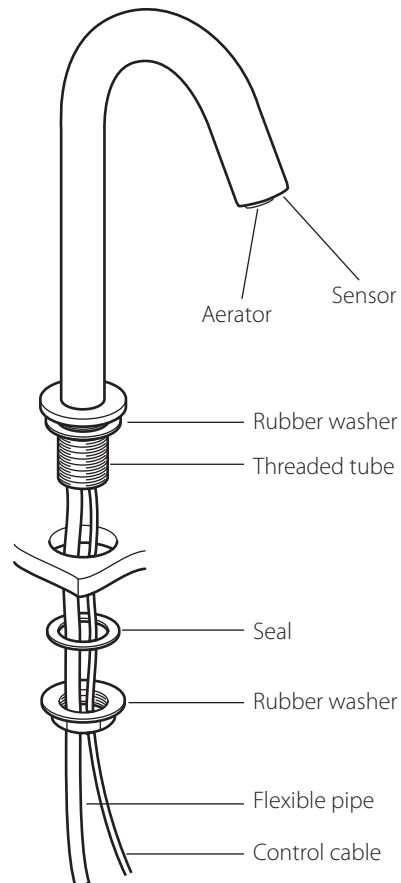

battery installation and replacement

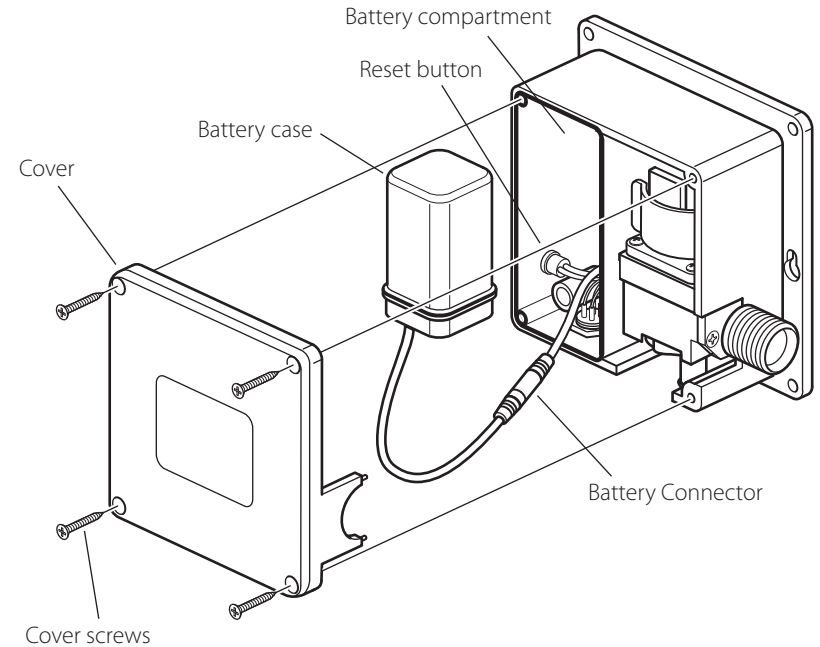

The unit is supplied with a battery backup, should the mains supply fail and the tap still will not function then the batteries may need replacing. Before installing the control box on the wall fit the supplied batteries as follows.

Remove the 4 screws retaining the cover and pull off, pull out the battery case (see above).

Undo the screw on the top and remove the lid. Insert the 4 batteries according to the diagram in the bottom of the base. Replace the lid making sure that the 2 springs are orientated to match the negative ends of 2 batteries. Place the battery case back into the compartment, fit the cover and replace the 4 screws.

