

BRISTAN

JS2 Thermostatic Recessed Valve with Three Outlet Diverter and Stopcock

PRODUCT CODE: JS2 SHC3DIV C

TELEPHONE HELPLINE: 0844 701 6273

Bristan Group Ltd
Birch Coppice Business Park
Dordon
Tamworth
Staffordshire
B78 1SG
UK
A Masco Company

Web Site: www.bristan.com
Telephone: 0844 701 6274
Facsimile: 0844 701 6275
Email: enquire@bristan.com

(FI JS2 SHC3DIV)

(Rev. D1)

(MZ)



Before starting any installation project, consider "safety" first. Look for the "safety note" sign and read the safety advice.

Installation Instructions

Please keep these instructions for future reference and for the ordering of spare parts.



CONTENTS

Section	Description	Page No:
1.	Introduction	2
2.	Specification	2
3.	Pack Contents Checklist	3
4.	Installation	3
5.	Operation & Setting	4
6.	Fault Diagnosis	5
7.	Cleaning & Maintenance	6
8.	Guarantee & Registration	8

1. INTRODUCTION

This mixer is suitable for use on high-pressure systems only with a recommended minimum of **1 bar**. For optimum use both the hot and the cold supplies should be reasonably balanced.

This mixer should be installed in compliance with Water Regulations. For further details contact your Local Water Authority.

Ensure that the hot water temperature is adequate; the recommended minimum temperature is 60°C. The hot water temperature should be at least 10°C higher than the blend temperature to ensure that the safety shut off will work.

2. SPECIFICATION

Inlet Connections: 15mm compression with 150mm between centres.
 Water Pressures: Min. 1.0 bar Max. 8 bar
 Maximum recommended imbalance between hot & cold pressures should not exceed a ratio of 5:1

Factory Set Max. Outlet Temp: 42°C (can be re-set to suit site conditions)

Hot Supply Temp. Min. recommended 60°C Max. Hot Supply 80°C
Cold supply Temp. Max. 25°C

8. GUARANTEE AND REGISTRATION

8.1 Guarantee

All products are manufactured to the highest standards and 5-year guarantee covers any defect in manufacture. Any part found to be defective during the above guarantee period will be replaced without charge providing that the product has been installed in accordance with our instructions, used as intended and maintained/serviced as recommended. In the unlikely event that any problems are encountered with this product's performance on installation, you must obtain guidance/authorization from our Customer Service Department before any remedial action is taken and be able to supply proof and date of purchase.

The guarantee excludes damage caused by accident, misuse or neglect and does not cover the following:

- Those components subject to wear and tear such as 'O' rings, washers etc,
- Damage caused by faulty installation,
- Damage caused by any waterborne debris,
- Damage caused by improper cleaning products,
- Damage caused by the use of non-Bristan parts,
- The product being used for a purpose other than intended.

The company reserves the right, in the event of a claim not covered by the guarantee, to charge the claimant for parts and labour at current rates. This guarantee is given in addition to and does not affect your statutory rights.

In the interests of continuous product development we reserve the right to alter the specification as necessary.

8.2 Registration

To register your product with us please complete and return the enclosed registration card.

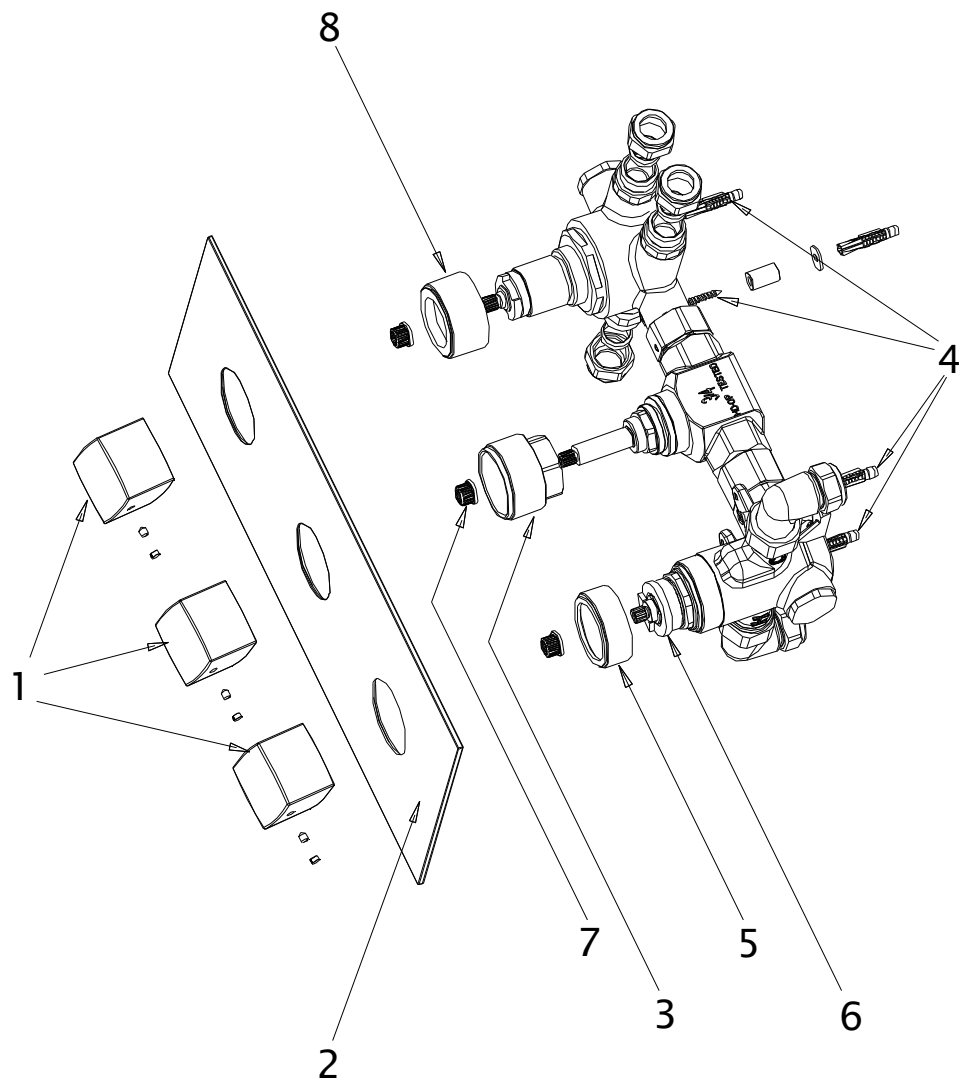

3. CONTENTS

1. Handle	(x3)	5. Temperature Body Cover	(x1)
2. Concealing Plate	(x1)	6. Temperature Stop	(x1)
3. Valve Body Cover	(x3)	7. Spline Adaptor	(x3)
4. Wall Fixings	(x4)	8. Diverter Body Cover	(x1)

4. INSTALLATION

This thermostatic valve should be installed to provide a mixed water supply to the rest of the system. It has four lugs on the body to provide mounting points to a batten or directly to the inner wall within a cavity. Additional support should be provided by rigid pipework. The valve features 5 x 15mm compression fittings, 2 on the inlet elbows set at 150mm centers allow connections to hot and cold supplies, and 3 on the diverter to feed three alternate outlets. An additional outlet can be accessed, by removing the blanking plug at the base of the valve (adaptor not supplied). The use of an additional stop cock will be required.

4.1 Identify all components and check for completeness, particularly before arranging fitting.

4.2 It is important to measure up the application to aid correct orientation and position of the valve, so that the concealing plate (2) will be held in place by it's integral retainers along the available length of the body covers (3,5 & 8)

4.3 Screw valve to supporting member or wall through the body lugs with the fixings provided (4). Connect the inlets to the appropriate hot and cold supply pipes using the 15mm compression connections (hot and cold are indicated by 'H' and 'C' on valve body). Connect outlets to installed fittings as required using 15mm compression connections.

4.4 Spline adaptors (7) are pre-assembled on the valve control spindles. The temperature control spindle is set in a position so that the factory pre-set temperature is met when the temperature handle is turned to maximum (anti-clockwise), from being fitted with the cap pointing downwards. This position is indicated by the two arrows on the spline adaptor being in line with the edges of the marker on the temperature stop (6) and should be maintained during assembly unless a higher temperature is required – see 'Adjustment' section

4.5 Turn on water supplies to check both correct valve function and for leaking from joints / connections.

NOTE: If it is necessary to use the handles during testing, remember the position of the temperature handle (the handle with the stop pin) is fitted in case the spline adaptor (7) stays in handle when removed.

4.6 Complete wall finish ensuring depth is correct to allow for fitting concealing plate (2) and handles (1). Please note that it is important to leave a gap around the body covers (3, 5 & 8) to allow removal for servicing as necessary.

4.7 Once dry, fit concealing plate (2), sealing with a bead of suitable silicone sealant in the groove on the rear of the plate to the wall surface.

4.8 Fit handles (1) by simply pushing onto spline adaptors (7), making sure flow valve is fully closed to give correct positioning of handle when 'off' and the diverter handle is aimed at desired outlet when in correct position.

5. OPERATION AND SETTING

5.1 Operation

There are 3 control handles on this valve. To control the flow turn the middle handle anti-clockwise to turn on and increase the flow, and clockwise to decrease and turn off. To control the temperature, turn the bottom handle anticlockwise for hotter and anticlockwise for colder. There are indications on the concealing plate that show this. The top control allows water to 3 different outlets, such as fixed head, body jets or an adjustable riser.

5.2 Setting

The temperature is factory set at 42°C. This can however be adjusted for site conditions or personal preference by removing the temperature control handle and shroud and turning the control spindle on the temperature valve in the required direction to increase or decrease the temperature as desired. Replace the shroud so that the pin inside the shroud is at the maximum anti-clockwise position against the temperature stop (6). Replace the handle back on the valve.

6. FAULT DIAGNOSIS

If your valve fails to function correctly, the following should be checked:

6.1 Check that the hot and cold connections are the correct way around. Hot on the left and cold on the right.

6.2 Ensure that the hot water temperature is adequate; the recommended minimum temperature is 60 °C. The hot water temperature should be at least 10 °C higher than the blend temperature to ensure that the safety shut off will work.

7. CLEANING AND MAINTENANCE

7.1 Cleaning

Your fitting has a high quality finish and should be treated with care to preserve the visible surfaces. All surface finishes will wear if not cleaned correctly; the only safe way to clean your mixer is to wipe it with a soft damp cloth. Stains can be removed using washing up liquid. All bath cleaning powders and liquids will damage the surface of your fitting, even non-scratch cleaners.

7.2 Maintenance

7.2.1 We advise that the valve be regularly serviced, particularly in hard water areas. It is also important to clean the outlet (i.e. shower head – not supplied) regularly in hard water areas to maintain an even spray/flow of water.

7.2.2 Remove handle (1) by simply pulling from spline adaptor (7). Adjust water temperature until at acceptable maximum level. Replace handle (1) with the stop pin against the temperature stop (6). Turn off the water supply. Remove handles (1) by simply pulling from spline adaptors (7). Remove concealing plate (2), using a suitable thin bladed tool to break silicon seal.

7.3 Temperature Control Maintenance

7.3.1 Unscrew temperature body-cover (5), remove temperature stop (6) and unscrew retaining collar with suitable spanner. Remove and clean cartridge, using suitable cleaner to remove any dirt, clean housing with damp cloth. Grease the O-rings on the cartridge. Replace the cartridge, retaining collar, temperature body cover and temperature stop.

7.4 Flow Control Maintenance

7.4.1 Remove valve body-cover (3), and unscrew valve using suitable spanner, clean seat and rubber washer. Replace valve and valve body-cover.

7.5 Diverter Maintenance

7.5.1 Unscrew diverter body-cover (8) and retaining nut. Remove spindle, retaining nut and cartridge. Check cartridge seals and ceramic discs for damage and debris. Re-assemble and test. Contact our help line if problem persists. Reseal and re-fit concealing plate using silicon and replace handles