

**PRODUCT CODE: PM BARSHXVOFF C**

**TELEPHONE HELP LINE! 0844 701 6273**

Bristan Group Ltd.  
Birch Coppice Business Park  
Dordon  
Tamworth  
Staffordshire  
B78 1SG  
UK

A Masco Company

Web Site: [www.bristan.com](http://www.bristan.com)  
Telephone: 0844 701 6274  
Facsimile: 0844 701 6275  
Email: [enquire@bristan.com](mailto:enquire@bristan.com)

(FI PM BARSHXVOFF C)

(REV.D1)

(MZ)

## Prism Thermostatic Surface Mounted Bar Shower Valve With Fast Fit Connections

### Fitting Instructions & Contents List



Before starting any installation project, consider "Safety" first. Look for the "safety note" sign and read the safety advice.

Prior to drilling into walls, check there are no hidden electrical wires, cables or water supply pipes with the aid of an electronic detector. If you use power tools do not forget:

- Wear eye protection
- Unplug equipment after use

**Please Keep These Instructions For Future Reference and Request of Replacement Parts.**

# Contents

Notes:-

Section	Description	Page No:
1.	Introduction	2
2.	Specification	2
3.	Pack contents checklist	2
4.	Installation	3
5.	Setting	6
6.	Operation	6
7.	General fault diagnosis	7
8.	Cleaning & Maintenance	7
9.	Guarantee & Registration	8
10.	Notes	9

## 10. Notes

## 1. Introduction

Your Bristan dual control shower fitting is a thermostatic mixer incorporating a wax capsule thermostat to ensure constant showering temperatures.

This valve has been designed to comply with BS EN 1287:1999 & BS EN1111:1999. Manufactured to the highest quality standards.

These instructions are for your guidance to a safe and successful installation and should be left with the user.

All products manufactured and supplied by Bristan are safe provided they are installed, used correctly and receive regular maintenance in accordance with these instructions.

## 2. Specification

Inlet Connections: 15mm compression with 150mm between centres.

Water Pressures: Min. 0.2 bar Max. 5 bar Maximum recommended imbalance between hot and cold supply should not exceed a ratio of 5:1

Maximum Outlet Temp: Factory Set to 38°C at the safety click and 48°C at the final stop (can be re-set to suit site conditions).

### Hot & Cold Supply Temperature

*Maximum Cold supply:* 25°C

*Minimum recommended hot supply:* 60°C

*Maximum Hot Supply:* 80°C

**Note: the inlet hot water temperature must be at least 10°C above the required blend temperature.**

## 3. Pack Contents Check List

- 1 x Shower Valve
- 4 x Screws
- 4 x Wall Plugs
- 2 x Wall Pate
- 2 x 15mm Olives
- 2 x Fixing Bridge
- 2 x Shroud
- 2 x Filter Washer

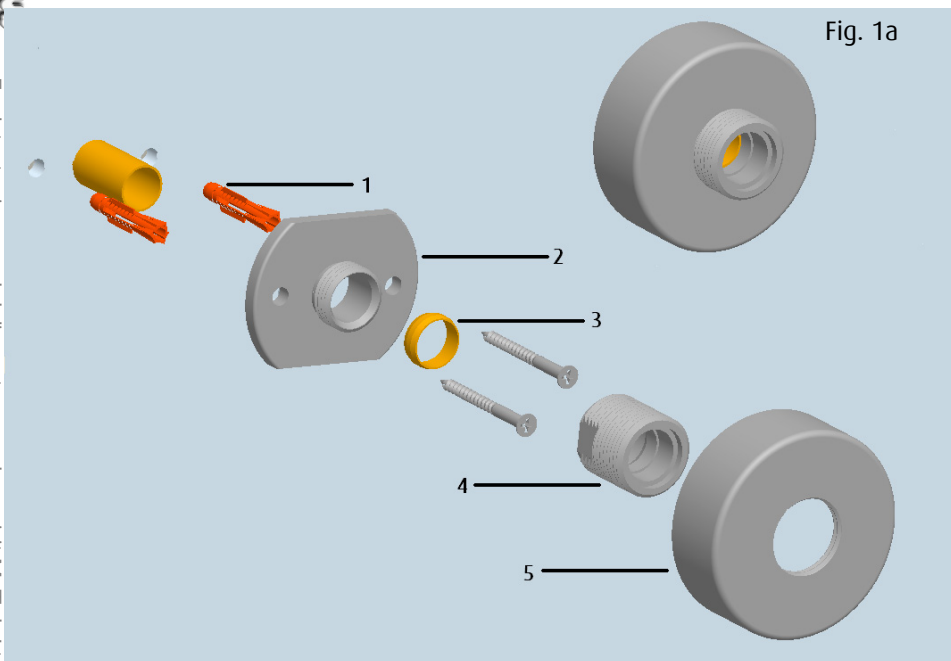

Fig. 1a

#### 4. Installation

##### 4.1 Pre-Installation (See Fig. 1a & 1b)

4.1.1 Identify all components and check for completeness, particularly before arranging fitting.

4.1.2 This mixer should be installed in compliance with Water Regulations. For further details contact your Local Water Authority.

4.1.3 This mixing valve is suitable for use with the following systems:

- Gravity Fed Hot & Cold (Equal Pressure)
- Gravity Fed Hot & Mains Cold (Differential Pressure Maximum Ratio 5:1)
- Un-vented Systems
- Thermal Store Systems
- Gas Combination Boiler
- Pumped System

##### **PLEASE NOTE:**

**On gravity systems the minimum distance from the underside of the cold-water storage tank to the shower head must be at least 1 metre.**

4.1.4 Before fitting the fast fit wall fixings, water should be flushed through the system to remove all debris from the pipe work.

#### 8.5 Refitting the Cartridge

8.5.1 Grease the seals with suitable silicon grease and carefully refit the cartridge into the body.

8.5.2 Reset the maximum temperature and refit temperature handle

### 9. Guarantee & Registration

#### 9.1 Guarantee

All products are manufactured to the highest standards and 5-year guarantee covers any defect in manufacture.

Any part found to be defective during the above guarantee period will be replaced without charge providing that the product has been installed in accordance with our instructions, used as intended and maintained/serviced as recommended.

In the unlikely event that any problems are encountered with this product's performance on installation, you must obtain guidance/authorisation from our Customer Service Department before any remedial action is taken and be able to supply proof and date of purchase.

The guarantee excludes damage caused by accident, misuse or neglect and does not cover the following:

Those components subject to wear and tear such as 'O' rings and washers etc,

- Damage caused by faulty installation,
- Damage caused by any waterborne debris,
- Damage caused by improper cleaning products,
- Damage caused by the use of non-Bristan parts,
- The product being used for a purpose other than intended.

The company reserves the right, in the event of a claim not covered by the guarantee, to charge the claimant for parts and labour at current rates. This guarantee is given in addition to and does not affect your statutory rights.

*In the interests of continuous product development Bristan Limited reserve the right to alter the specification as necessary.*

#### 9.2 Registration

To register your product with us please complete and return the enclosed registration card.

## 7. General Fault Diagnosis

**7.1** If your valve fails to function correctly, the following should be checked:

**7.1.1** Check that the hot and cold connections are the correct way around. Hot on the left, cold on the right when viewed from the front.

**7.1.2** Ensure that the hot water temperature is adequate. The recommended minimum temperature is 60°C.

**7.2** If your shower will not turn off:

**7.2.1** Check ceramic disc valve is free of debris.

**7.3** If your shower has a low flow rate.

**7.3.1** Check that the filters (6) are not blocked.

## 8. Cleaning & Maintenance

### 8.1 Cleaning

Your fitting has a high quality finish and should be treated with care to preserve the visible surfaces.

All surface finishes will wear if not cleaned correctly, the only safe way to clean your mixer is to wipe with a soft damp cloth. Stains can be removed using washing up liquid. All bath cleaning powders and liquids will damage the surface of your fitting, even the non-scratch cleaners.

### 8.2 Regular Maintenance

We advise that the valve is regularly serviced, particularly in hard water areas. It is also important to clean the handset regularly in hard water areas to maintain an even spray/flow of water.

**NOTE: ISOLATE THE WATER SUPPLY TO THE SHOWER VALVE.**

### 8.3 Cartridge Removal (See Fig. 1b)

**8.3.1** Remove the temperature control handle (10) by removing the peg (8), loosening the grub screw (9) and pulling the handle off the spindle.

**8.3.2** Unscrew the cartridge retaining nut (14) anticlockwise and pull the cartridge out of the body.

### 8.4 Cartridge Maintenance

**8.4.1** Place the cartridge in a bowl and carefully add some hot water (just off the boil) and vinegar to de-scale the cartridge. Leave until the water has cooled.

**8.4.2** Then remove the cartridge and rinse with clean water.

## 4.2 Installation



Prior to drilling into walls, check there are no hidden electrical wires, cables or water supply pipes with the aid of an electronic detector. If you use power tools do not forget:

- Wear eye protection
- Unplug equipment after use

### 4.2.1 Fast Fit Fixing Kit (See Fig. 1a)

**4.2.1.1** Identify all components and check for completeness, particularly before arranging fitting.

**NOTE: - THE fixing centres are a NOMINAL DISTANCE of 150mm, therefore before drilling holes for the supply pipes check the centre dimension of the actual product to be used.**

**4.2.1.2** Inlet pipes need to terminate with at least 30mm of 15mm diameter pipe (not supplied) protruding through the finished wall surface.

**Important:- Water supplies to the mixer must be with the Hot on the left, & Cold on the right when viewed from the front .**

**4.2.1.3** Place the wall plate (2) over the pipe and mark the hole centres, drill two holes to suit the wall plugs (1) and insert the wall plugs into the freshly drilled holes in the wall.

**4.2.1.4** Place the wall plate (2) with onto the wall and tighten up the screws until secure. Place the olive (3) onto the protruding 15mm pipe. The pipe needs to protrude past the olive by 5mm maximum.

**4.2.1.5** Screw the fixing bridge (4) onto the wall plate (2) using a 22mm a/f spanner, holding the wall plate (2) with the flats provided with a 47mm spanner – **DO NOT** tighten up the fixing bridge (4) against the fixings (1).

**4.2.1.6** Screw shroud (5) onto fixing bridge (4).

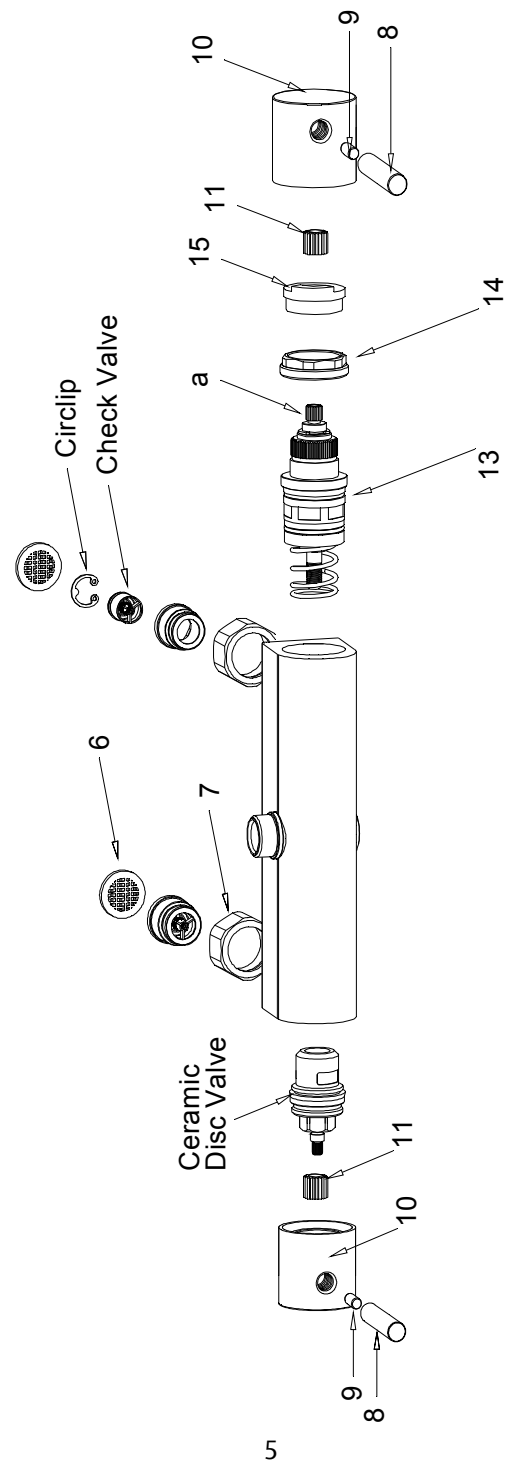

Fig. 1b

#### 4.2.2 Bar Shower Body (See Fig. 1b)

4.2.2.1 To fit mixer body to the wall. Place the filter washers (6) into the connecting nuts (7) and tighten to the fixing bridge (4 on page 3, Fig. 1a) using the connecting nuts (7) which are secured to the mixer body.

4.2.2.1 For top outlet applications, unscrew the blanking plug from the top of the bar shower and unscrew the bottom outlet with a suitable sized hexagonal key and screw them back in to the relevant holes in the shower body.

### 5. Setting

5.1 The maximum temperature (beyond the 38°C click) can be adjusted to suit site conditions or user preference. To adjust this, follow this procedure:

5.2 Position the temperature control handle to the click stop point and turn on the flow handle control letting the water run long enough to ensure that the hot water supply is at its maximum temperature.

5.3 The shower has been factory set to 38°C at the click position with balanced supply pressures of 0.5 Bar.

5.4 **Whilst the water is flowing** remove the temperature control handle (10), by removing the peg (8) on the handle loosen the grub screw (9) and pull the handle off the spindle (a).

5.5 Turn the spindle (a) until the required maximum temperature is achieved, anti-clockwise to increase the temperature and clockwise to reduce it.

5.6 **Important:** Refit the shroud and handle so that the stop pin in the handle (14) fits inside the rim of the white nylon stop ring .

5.7 Tighten the grub screw and turn clockwise. The handle should click. This is quite normal.

5.8 Turn off the flow at the flow control handle.

### 6. Operation

#### 6.1 On / Off - Flow Control

There are two control handles on the shower. Turn the flow control handle (left) anti-clockwise to turn on and increase the flow, and clockwise to decrease and turn off. The temperature control handle (right) is turned anti-clockwise for hot, clockwise for cold and features a 'temperature click notch'. The 'click' is factory set to 38°C, but can be over ridden by turning the handle anticlockwise past the click stop position.