



## AFTERCARE INSTRUCTIONS

Your fitting has a high quality finish and should be treated with care to preserve the visible surfaces. All surface finishes will wear if not cleaned correctly, the only safe way to clean your mixer is to wipe with a soft damp cloth. Stains can be removed using washing up liquid. All bath cleaning powders and liquids will damage the surface of your fitting - even non-scratch cleaners.

## GUARANTEE

All products are manufactured to the highest standards and a 5 year guarantee covers any defect in manufacture.

**NOTE:** The 5 year guarantee on the valves is invalidated if damaged by any waterborne debris.

*In the interests of continuous product development we reserve the right to alter specification as necessary.*

**PRODUCT CODE: J MBAS C**

**TELEPHONE HELP LINE: 0844 701 6273**

Bristan Group Ltd  
Birch Coppice Business Park  
Dordon  
Tamworth  
Staffordshire  
B78 1SG  
UK  
A Masco Company

Web Site: [www.bristan.com](http://www.bristan.com)  
Telephone: 0844 701 6274  
Facsimile: 0844 701 6275  
Email: [enquire@bristan.com](mailto:enquire@bristan.com)

(FI J MBAS)

(R2)

(H)

# BRISTAN

## Java Mini Basin Mixer

## Fitting Instructions & Contents List

**Please keep these instructions for future reference and for the ordering of spare parts.**

## WATER PRESSURE

This mixer is suitable for use at all supply pressures. However for optimum use both the hot and cold supplies should be reasonably balanced. If the fitting is installed at low pressure (tank fed), then the minimum distance from the outlet of the nozzle to the underside of the cold tank should be approximately 5 metres to ensure adequate performance.

This mixer should be installed in compliance with Water Regulations. Where the supplies are unbalanced, i.e. hot water from the cylinder tank/cold from the mains, approved check valves must be fitted in the supply pipes. For further details contact your Local Water Authority.

### CONTENTS

1. Mixer body
2. Pop-up operating rod (2 piece)
3. Plinth
4. C-shaped rubber washer
5. C-shaped metal washer
6. Securing nuts (x2)
7. Tailpipes
8. Threaded rods (x2)
9. Waste rod
10. Waste body
11. Washer
12. Washer
13. Waste flange
14. Plug
15. O-ring

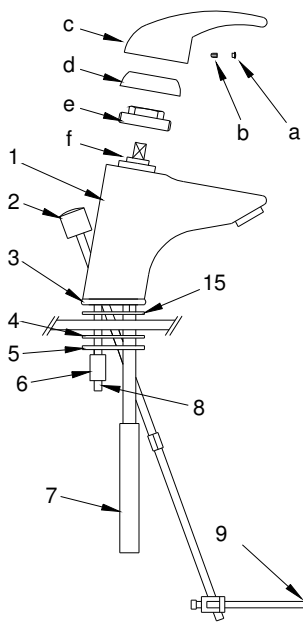

## INSTALLATION

1. Identify all components and check for completeness, particularly before arranging fitting.
2. Fit the mixer body (1) to the basin using the 'C' plate fixing kit. The plinth (3) and 'O' ring (15) go between the fitting and the basin, and the 'C' shaped rubber (4) and metal washers (5) on the underside of the basin. Secure into position using threaded rods (8) and nuts (6).
3. Screw in the inlet connection tailpipes by hand (7) to the fitting and connect the hot and cold supplies.
4. Fit the pop up waste, using washers (11) below & (12) above the basin/bidet and connect it to the mixer. It is recommended that a silicon sealant be applied to both sealing faces of washers (11) and (12) The waste can be set by adjusting the waste rod (9) / operating rod (2) connecting bracket and the screw in the base of the plug (14).
5. Fully open the mixer in the mid position, letting it run for a few minutes to check all joints and connections for leaks.
6. See over the page for aftercare instructions.

## MAINTENANCE

If the fitting begins to drip:

1. Turn off the water supply.
  2. Remove indices cap (a), loosen grub screw (b) with a hexagon key and pull off head (c), unscrew shroud (d) retaining nut (e).
  3. Remove cartridge (f).
  4. Clean or replace cartridge, clean and grease seal and refit.
- Note: that there are locating pins on the bottom of the cartridge that fit in holes inside the tap, to ensure it is fitted the right way round.
5. Replace cartridge and head and turn on the water supply.
  6. Contact our helpline if problem persists.

Please Note: In the unlikely event you find a part missing please contact our Customer Service Helpline on 0844 701 6273 or email [enquire@bristan.com](mailto:enquire@bristan.com) for immediate despatch of part.