

AFTERCARE INSTRUCTIONS

Your fitting has a high quality finish and should be treated with care to preserve the visible surfaces. All surface finishes will wear if not cleaned correctly, the only safe way to clean your tap is to wipe with a soft damp cloth. Stains can be removed using washing up liquid. All bath cleaning powders and liquids will damage the surface of your fitting even the non-scratch cleaners.

GUARANTEE

All products are manufactured to the highest standards and a 5 year guarantee covers any defect in manufacture.

NOTE: - the 5 year guarantee on the valves is invalidated if damaged by any waterborne debris.

In the interests of continuous product development Bristan reserve the right to alter specification as necessary

PRODUCT CODE: RO 1/2 C / RO 3/4 C
TELEPHONE HELP LINE : 0844 701 6273

Bristan Group Ltd
Birch Coppice Business Park
Dordon
Tamworth
Staffordshire
B78 1SG
UK
A Masco Company

Web Site: www.bristan.com
Telephone: 0844 701 6274
Facsimile: 0844 701 6275
Email: enquire@bristan.com

BRISTAN

Rio Basin & Bath Taps

Fitting Instructions & Contents List

Please keep these instructions for future reference and request of replacement parts.

(FI RO TAP)

(Rev. D3)

(H)

For latest prices and delivery to your door visit MyTub Ltd 0845 303 8383 www.mytub.co.uk



WATER PRESSURE

These taps are suitable for use at all supply pressures. If the taps are installed at low pressure (tank fed), then the minimum height from the outlet of the nozzle to the underside of the cold tank should be 2 metres to ensure adequate performance.

These taps should be installed in compliance with Water Regulations. For further details contact your Local Water Authority.

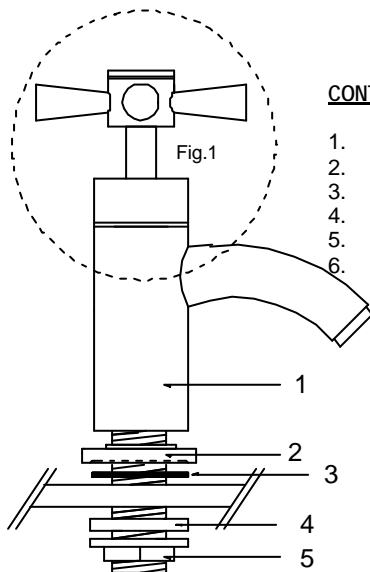

CONTENTS

- | | | |
|----|---------------|------|
| 1. | Body | (x2) |
| 2. | Plinth | (x2) |
| 3. | Rubber O-Ring | (x2) |
| 4. | Washer | (x2) |
| 5. | Backnut | (x2) |
| 6. | Aerator* | (x2) |

Please Note: -

In the unlikely event you find a part missing please contact our Customer Service Help line on 0844 701 6273 or e-mail enquire@bristan.com for immediate dispatch of part.

INSTALLATION

1. Identify all components and check for completeness, particularly before arranging fitting.
2. Install the taps (1) into the basin or bath, using the washers (4) above and backnuts (5) below basin or bath. The plinth (2) and O-ring (3) go between the taps and the bath or basin.
3. Connect the hot and cold water supplies.
4. Turn on the water supplies. Open both taps letting the water flow for a few minutes to check all joints and connections for leaks.
5. See over the page for aftercare instructions.
6. To fit the Aerator unscrew the flow straightener for the end of the spout and screw in the replacement aerator.

Note:- * The aerator is only supplied with the basin taps and should only be fitted to taps on pressurised systems.

MAINTENANCE

If the fitting begins to drip:

1. Turn off the water supply.
2. Unscrew cap (a), remove indice (b) loosen screw (c) and remove handle (d).
3. Unscrew shroud (e) and remove ceramic disc valve (f).
3. Carefully clean seating and rubber washer.
4. Replace components and turn on the water supply.
5. Contact our helpline if problem persists.

