



AFTERCARE INSTRUCTIONS

Your fitting has a high quality finish and should be treated with care to preserve the visible surfaces. All surface finishes will wear if not cleaned correctly, the only safe way to clean your mixer is to wipe with a soft damp cloth. Stains can be removed using washing up liquid. All bath cleaning powders and liquids will damage the surface of your fitting even the non scratch cleaners.

GUARANTEE

All products are manufactured to the highest standards and a 5 year guarantee covers any defect in manufacture. As gold and special effect finishes are softer than chromium plate, special care must be taken when cleaning; a 3 year guarantee covers these finishes.

NOTE: The 5 year guarantee on the valve is invalidated if damaged by any waterborne debris.

In the interests of continuous product development Bristan reserve the right to alter specification as necessary.

PRODUCT CODE: J SLPBF C / G / COM / SC
TELEPHONE HELPLINE: 0844 701 6273

Bristan Group Ltd
Birch Coppice Business Park
Dordon
Tamworth
Staffordshire
B78 15G
UK
A Masco Company

Web Site: www.bristan.com
Telephone: 0844 701 6274
Facsimile: 0844 701 6275
Email: enquire@bristan.com
(F) J SLPBF) (R2)

(H)

BRISTAN

Java Single Lever Pillar Bath Filler

Fitting Instructions

Please keep these instructions for future reference and request of replacement parts.

WATER PRESSURE

This mixer is suitable for high pressure plumbing systems only with minimum pressure of 1 bar. However for optimum use both the hot and cold supplies should be reasonably balanced.

This mixer should be installed in compliance with Water Regulations. Where the supplies are unbalanced, i.e. hot water from cylinder tank/cold from the mains, approved check valves must be fitted in the supply pipes. For further details contact your Local Water Authority.

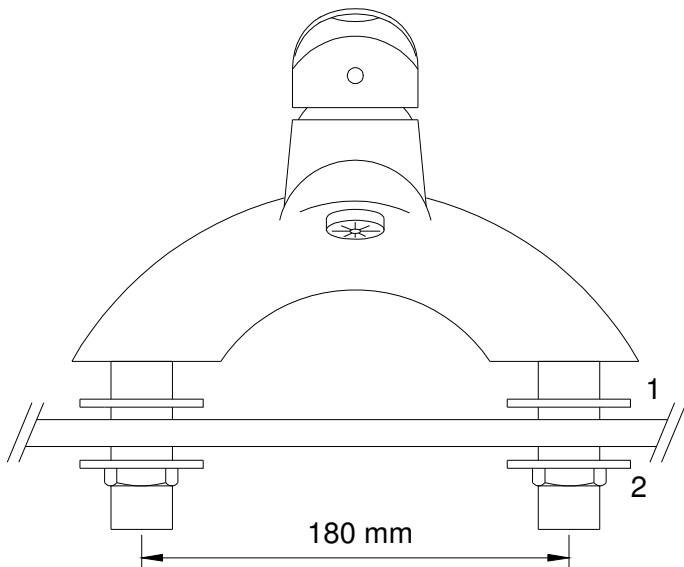

INSTALLATION

1. Identify all components and check for completeness, particularly before arranging fitting.
2. Fit the mixer body to the bath using the washers (1) above and the backnuts (2) below the bath, and then connect the hot and cold water supplies.
3. Fully open the mixer in the mid position, letting it run for a few minutes and check all joints and connections for leaks.
4. See over the page for aftercare instructions.
5. See over the page for aftercare instructions.

MAINTENANCE

If the fitting begins to drip:

1. Isolate water supplies.
2. Prise out handle cap, loosen grub screw and lift off the handle.
3. Unscrew the shroud and brass retaining plate and lift out the cartridge complete with seal.
4. Clean or replace cartridge, clean and grease seal and refit.
Note: that there are locating pins on the bottom of the cartridge that fit in holes inside the tap, to ensure it is fitted the right way round.
5. Refit the handle and tighten the grub screw. Replace the handle cap.
6. If problem persists contact our helpline quoting the product code.

Please Note: In the unlikely event you find a part missing please contact our Customer Service Helpline on 0870 4425553 or email enquire@bristan.com for immediate dispatch of part.