



For latest prices and delivery to your door visit MyTub Ltd 0845 303 8383 www.mytub.co.uk

## AFTERCARE INSTRUCTIONS

Your fitting has a high quality finish and should be treated with care to preserve the visible surfaces. All surface finishes will wear if not cleaned correctly, the only safe way to clean your mixer is to wipe with a soft damp cloth. Stains can be removed using washing up liquid. All bath cleaning powders and liquids will damage the surface of your fitting even the non-scratch cleaners.

## GUARANTEE

All products are manufactured to the highest standards and a 5 year guarantee covers any defect in manufacture. As gold and special effect finishes are softer than chromium plate, special care must be taken when cleaning; a 3 year guarantee covers these finishes.

**NOTE:** The 5 year guarantee on the valves is invalidated if damaged by any waterborne debris.

*In the interests of continuous product development we reserve the right to alter specification as necessary.*

**PRODUCT CODE: PM SNK C**

**TELEPHONE HELP LINE: 0844 701 6273**

Bristan Group Ltd  
Birch Coppice Business Park  
Dordon  
Tamworth  
Staffordshire  
B78 1SG  
UK  
A Masco Company

Web Site: [www.bristan.com](http://www.bristan.com)  
Telephone: 0844 701 6274  
Facsimile: 0844 701 6275  
Email: [enquire@bristan.com](mailto:enquire@bristan.com)

(FI PM SNK)

(Rev. D2)

(H)

# BRISTAN

## Prism Kitchen Mixer

## Fitting Instructions

**Please keep these instructions for future reference and for the ordering of spare parts.**

## WATER PRESSURE

This mixer is suitable for use at all supply pressures. If the fitting is installed at low pressure (tank fed), then the minimum height from the outlet of the nozzle to the underside of the cold tank should be approximately 2 metres to ensure adequate performance. This mixer should be installed in compliance with Water Regulations. Where the supplies are unbalanced, i.e. hot water from the cylinder tank/cold from the mains, approved check valves must be fitted in the supply pipes. For further details contact your Local Water Authority.

## CONTENTS

1. Mixer (x1)
2. Plinth (x1)
3. O-ring (x1)
4. C-shaped rubber washer (x1)
5. C-shaped metal washer (x1)
6. Threaded rod (x2)
7. Retainer (x2)
8. Tail pipes (x2)
9. Check valve (x1)

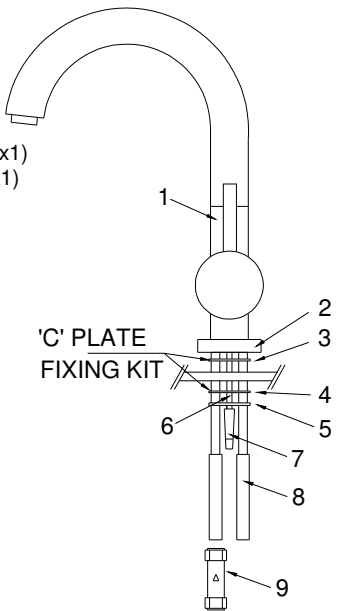

## INSTALLATION

1. Identify all components and check for completeness, particularly before arranging installation.
2. Fit the mixer body (1) to the sink using the 'C' plate fixing kit. The metal plinth (2) and o-ring (3) go between the fitting and the sink, and the 'C' shaped rubber (4) and metal (5) washers on the underside of the sink to be secured by the threaded rod (6) and retainer (7)
3. Screw the tail pipes (8) into to the fitting, fit the check valve (9) to the hot side and connect the hot and cold supplies. **Note: with the handle on the right, the hot supply should be connected on the left.**
4. Fully open the mixer in the mid position and check all joints and connections for leaks.
5. See over the page for aftercare instructions.

## MAINTENANCE AND/OR CARTRIDGE REPLACEMENT

1. Isolate water supplies.
  2. Lever out the small indice plug in the front of the handle. Unscrew the grub screw and lift off the handle.
  3. Unscrew the shroud and brass retaining plate and lift out the cartridge complete with seals.
  4. Grease seal and fit the new cartridge.
- Note** that there are locating pins on the bottom of the cartridge that fit in holes inside the tap, to ensure it is fitted the right way round.
5. Refit the handle and tighten the grub screw. Replace the indice plug.

**Please Note:** In the unlikely event you find a part missing please contact our Customer Service Help line on 0844 701 6273 for immediate despatch of part.