

## AFTERCARE INSTRUCTIONS

Your fitting has a high quality finish and should be treated with care to preserve the visible surfaces. All surface finishes will wear if not cleaned correctly, the only safe way to clean your mixer is to wipe with a soft damp cloth. Stains can be removed using washing up liquid. All bath cleaning powders and liquids will damage the surface of your fitting - even non-scratch cleaners.

## GUARANTEE

All products are manufactured to the highest standards and a 5 year guarantee covers any defect in manufacture. As gold and special effect finishes are softer than chromium plate, special care must be taken when cleaning; a 3 year guarantee covers these finishes.

## PRODUCT CODE:

TELEPHONE HELP LINE: 0844 701 6273

Bristan Group Ltd  
Birch Coppice Business Park  
Dordon  
Tamworth  
Staffordshire  
B78 1SG  
UK  
A Masco Company

Web Site: [www.bristan.com](http://www.bristan.com)  
Telephone: 0844 701 6274  
Facsimile: 0844 701 6275  
Email: [enquire@bristan.com](mailto:enquire@bristan.com)

(FI W BSN12)

(R2)

(I)

# BRISTAN

## Clicker Basin Waste

(W BSN12 C/G/SAT/ST)

## Fitting Instructions

Please keep these instructions for future reference and request of replacement parts.



For latest prices and delivery to your door visit MyTub Ltd 0845 303 8383 [www.mytub.co.uk](http://www.mytub.co.uk)

## INSTALLATION

**Please Note:** Before Installation, please write the name and product code of your fitting in the spaces provided overleaf. This will ensure a speedier service if you should need to phone the help line.

1. Identify all components and check for completeness.
2. Fit the waste body (1) and rubber washer (2) into the basin.
3. Use a pure Silicon sealant where necessary. Place shaped rubber washer (3) under the basin and secure waste by tightening backnut (4) as shown on the diagram.
4. In order to fill the basin, the button in the middle of the waste needs to be pressed down. To release water, press button again.
5. Check all joints and connections for leaks.
6. See over the page for aftercare instructions.

## COMPONENTS

1. Waste body
2. Rubber washer
3. Shaped rubber washer
4. Backnut

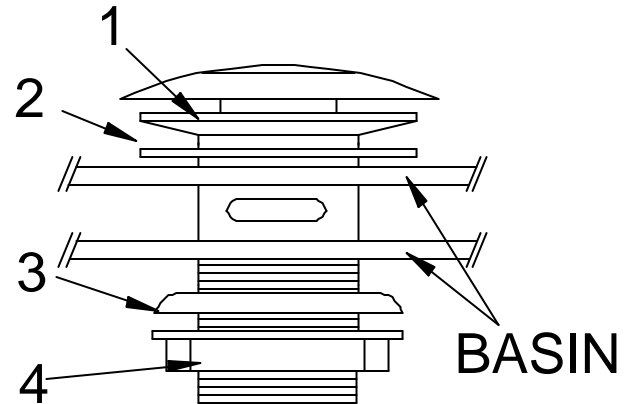

**Please Note:** In the unlikely event you find a part missing please contact our Customer Service Help line on 0844 701 6273 or email [enquire@bristan.com](mailto:enquire@bristan.com) for immediate dispatch of part.