

AFTERCARE INSTRUCTIONS

Your fitting has a high quality finish and should be treated with care to preserve the visible surfaces. All surface finishes will wear if not cleaned correctly, the only safe way to clean your mixer is to wipe with a soft damp cloth. Stains can be removed using washing up liquid. All bath cleaning powders and liquids will damage the surface of your fitting even the non-scratch cleaners.

GUARANTEE

All products are manufactured to the highest standards and a 5 year guarantee covers any defect in manufacture. As gold and special effect finishes are softer than chromium plate, special care must be taken when cleaning; a 3 year guarantee covers these.

NOTE: The 5 year guarantee on the valves is invalidated if damaged by any water born debris.

PRODUCT CODE: J BSM

TELEPHONE HELPLINE: 0870 4425556

Bristan Group Ltd
Birch Coppice Business Park
Dordon
Tamworth
Staffordshire
B78 1SG
UK
A Masco Company

Web Site: www.bristan.com
Telephone: 0870 4425556
Facsimile: 0870 1611002
Email: enquire@bristan.com
(FI JMTSH BSM) (R2)

BRISTAN

Java / Matrix / Shadow Deck Mounted Bath Shower Mixer

Fitting Instructions

Please keep these instructions for future reference.

WATER PRESSURE

This mixer is suitable for use at all supply pressures. However for optimum use both the hot and cold supplies should be reasonably balanced. If the fitting is installed at low pressure (tank fed), then the minimum height from the highest installed position of the showerhead to the underside of the cold tank should be 1 metre to ensure adequate shower performance.

This mixer should be installed in compliance with Water Regulations. Where the supplies are unbalanced, i.e. hot water from cylinder tank/cold from the mains, approved check valves must be fitted in the supply pipes. For further details contact your Local Water Authority.

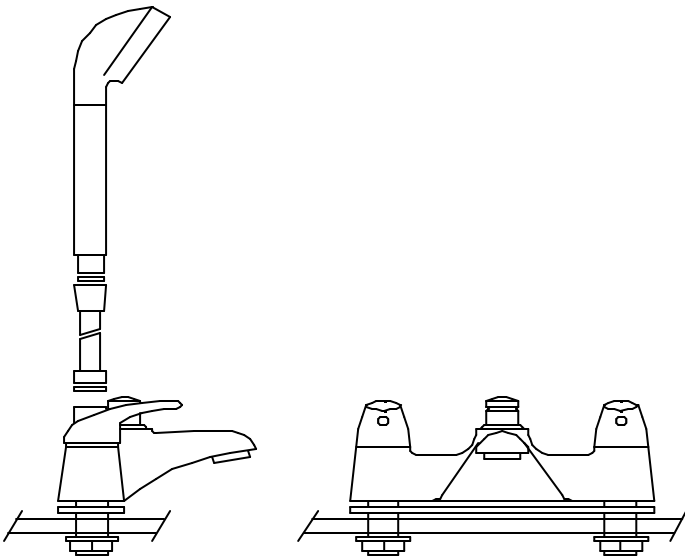

INSTALLATION

1. Identify all components and check for completeness, particularly before arranging fitting.
2. Fit the mixer body to the bath using the gasket and backnuts, connect the hot and cold water supplies.
3. Fit the hose to the mixer and the handset using the small sealing washers.
4. Fix the wall bracket to the wall ensuring that the handset will reach it.
5. Fully open both valves, letting them run for a few minutes to flush the system.
6. Operate the mixer in both bath and shower mode. To switch from bath to shower mode, pull the diverter up. After use the mixer automatically reverts to the bath filling mode.
7. See over the page for aftercare instructions.

MAINTENANCE

If the fitting begins to drip:

1. Turn off the water supply.
2. Prise off cap, loosen grub screw with 2.5mm hexagon key and pull off head.
3. Remove valve.
4. Carefully clean seating, rubber washer and ceramic disc.
5. Replace valve and head and turn on the water supply.
6. Contact our helpline if problem persists.

Please note: Before Installation, please write the name and product code of your fitting in the spaces provided overleaf. This will ensure a speedier service if you should need to phone the help line.