



## AFTERCARE INSTRUCTIONS

Your fitting has a high quality finish and should be treated with care to preserve the visible surfaces.

All surface finishes will wear if not cleaned correctly, the only safe way to clean your tap is to wipe with a soft damp cloth. Stains can be removed using washing up liquid. All bath cleaning powders and liquids will damage the surface of your fitting even the non-scratch cleaners.

## GUARANTEE

All products are manufactured to the highest standards and a 5 year guarantee covers any defect in manufacture.

As gold and special effect finishes are softer than chromium plate, special care must be taken when cleaning; a 3 year guarantee covers these finishes.

**NOTE: - the 5 year guarantee on the valves is invalidated if damaged by any waterborne debris.**

**PRODUCT NAME:**

**PRODUCT CODE:**

**TELEPHONE HELP LINE! +44 (0)870 442 5553**

Bristan Group Limited  
Birch Coppice Business Park  
Dordon  
Tamworth  
Staffordshire  
B78 1SG  
UK

A Masco Company

Web Site: [www.bristan.com](http://www.bristan.com)

Telephone: +44 (0)870 442 5556

Facsimile: +44 (0)870 442 5554

Email: [enquire@bristan.com](mailto:enquire@bristan.com)

(FI TAP (U))

(REV.D2)

(U)

# BRISTAN

## Basin, Bath And Sink Taps

## Fitting Instructions

Please keep these instructions for future reference and for the request of spare parts

## WATER PRESSURE

These taps are suitable for use at all supply pressures. If the taps are installed at low pressure (tank fed), then the minimum height from the outlet of the nozzle to the underside of the cold tank should be 1.8 metres to ensure adequate performance.

These taps should be installed in compliance with Water Regulations. For further details contact your Local Water Authority.

## INSTALLATION

1. Identify all components and check for completeness, particularly before arranging fitting.
2. Install the taps into the basin, bath or sink, using the washers and backnuts provided.
3. Connect the hot and cold water supplies.
4. Turn on the water supplies. Open both taps letting the water flow for a few minutes to check all joints and connections for leaks.
5. See over the page for aftercare instructions.

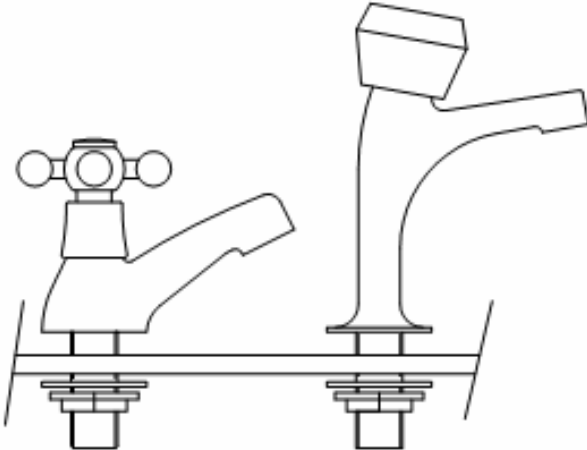

## MAINTENANCE

**Traditional valve type:** - If the fitting leaks from the spindle

1. Remove fitting head and shroud (if necessary).
2. Tighten gland nut as shown in diagram.

**All valve types:** - If the fitting begins to drip

1. Turn off the water supply.
2. Remove fitting head and valve.
3. Carefully clean seating and rubber washer.
4. Replace valve and turn on the water supply.
5. Contact our helpline quoting product code if problem persists.

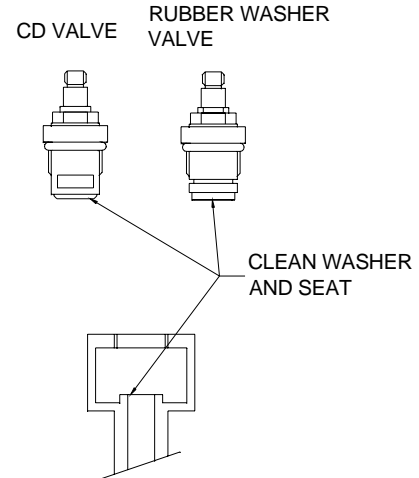

### Please Note: -

In the unlikely event you find a part missing please contact our customer Service Help line on +44 (0)870 442 5553 for immediate despatch of part.