

BRISTAN

Blaze Thermostatic Shower Mixer

(Universal Valve with Adjustable Riser or Recessed Valve with Fixed Head)

Fitting Instructions & Contents List



Before starting any installation project, consider "Safety" first. Look for the "safety note" sign and read the safety advice.

Prior to drilling into walls, check there are no hidden electrical wires, cables or water supply pipes with the aid of an electronic detector. If you use power tools do not forget:

- Wear eye protection
- Unplug equipment after use

Please Keep These Instructions for Future Reference and Request of Replacement Parts.

Contents

Section	Description	Page No:
1.	Introduction	2
2.	Specification	2
3.	Pack contents checklist	3
4.	Installation	5
5.	Setting	9
6.	Operation	10
7.	General fault diagnosis	10
8.	Cleaning & Maintenance	11
9.	Guarantee & Registration	15

1. Introduction

Your Bristan dual control shower fitting is a thermostatic mixer incorporating a wax capsule thermostat to ensure constant showering temperatures.

This valve has been designed & tested to comply with BS EN 1287:1999 & BS EN1111:1999. Manufactured to the highest quality standards.

These instructions are for your guidance to a safe and successful installation and should be left with the user.

All products manufactured and supplied by Bristan are safe provided they are installed, used correctly and receive regular maintenance in accordance with these instructions.

2. Specification

Inlet Connections: 15mm compression with 150mm between centres.

Water Pressures: Min. 0.1 bar Max. 5 bar Maximum recommended imbalance between hot and cold supply should not exceed 5:1

Maximum Outlet Temp: Factory Set to 42°C (can be re-set to suit site conditions).

Hot & Cold Supply Temperature

Maximum Cold Supply: 25°C

Minimum Recommended Hot Supply: 60°C

Maximum Hot Supply: 80°C

Note: the inlet hot water temperature must be at least 10°C above the required blend temperature.

3. Pack Contents Check List For Blaze Shower With Adjustable Riser (BZ CSHUAR C)

- 1 x Shower Valve
- 2 x Elbows
- 1 x Recessed Concealing Plate
- 2 x Elbow Concealing Plate
- 2 x Maintenance Tools
- 1 x Slider Rail
- 1 x Hose Retaining Ring
- 2 x Rail Wall Brackets
- 1 x Hose
- 1 x Handset
- 1 x Recessed Wall Fixing Plate
- 1 x Surface Mounted Wall Fixing Plate
- 1 x Wall Outlet
- 1 x Riser Rail Fixing Pack
- 1 x Shower Fixing Pack

Pack Contents Check List For Blaze Recessed Shower with Fixed Head (BZ CSHCFH C)

- 1 x Shower Valve
- 2 x Elbows
- 1 x Recessed Concealing Plate
- 2 x Maintenance Tools
- 1 x Recessed Wall Fixing Plate
- 1 x Shower Fixing Pack
- 1 x Fixed Head
- 1 x Shower Arm
- 1 x Arm Shroud
- 2 x Fixing Nuts

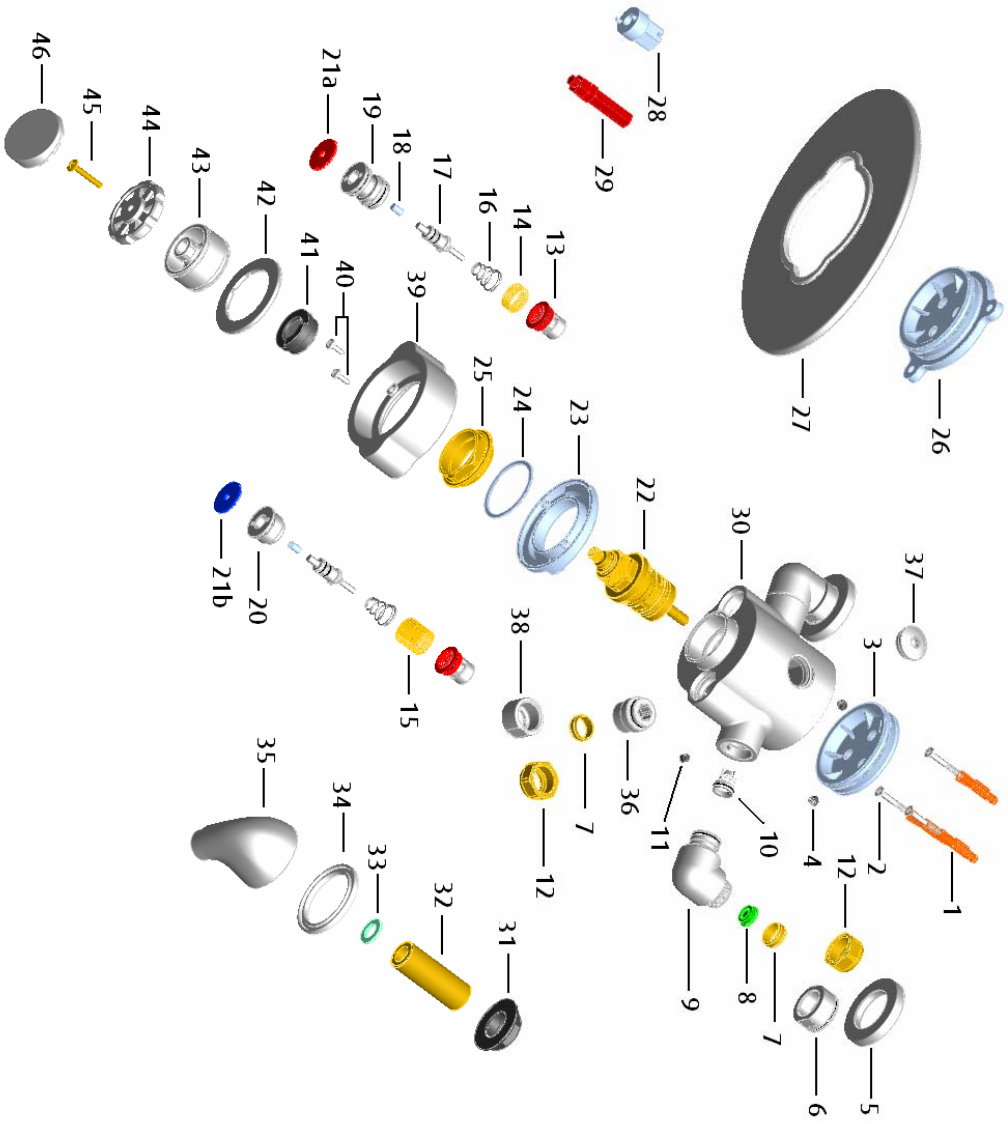

Fig. 1

4. Installation

4.1 Pre-Installation (See Fig.1)

4.1.1 Identify all components and check for completeness, particularly before arranging fitting.

4.1.2 This mixer should be installed in compliance with Water Regulations. For further details contact your Local Water Authority.

4.1.3 This mixing valve is suitable for use with the following systems:

- Gravity Fed Hot & Cold (Equal Pressure)
- Gravity Fed Hot & Mains Cold (Differential Pressure)
- Un-vented Systems
- Thermal Store Systems
- Gas Combination Boiler
- Pumped System

PLEASE NOTE:

On gravity systems the minimum distance from the underside of the cold-water storage tank to the showerhead must be at least 1 metre.

Prior to installation identify the supply system and the approximate supply pressures, and using the following table determine if flow limiters have to be fitted to the inlet elbows:

Pressure / Supply	Cold Pressure (bar)	Hot Pressure (bar)	Cold Elbow	Hot Elbow
Low Balanced or Unbalanced	0.1 to 1	0.1 to 1	No	No
Unbalanced	Above 1	0.1 to 1	Yes	No
High Balanced	Above 1	Above 1	Yes	Yes

4.1.4 To fit the flow limiter(s) (8) into the elbows (9), unscrew the inlet nut (6) and remove the olive (7). Install the flow limiter (8) (small diameter first) into the elbow inlet.

4.1.5 To fit the elbows (9) push the elbows in to the body and position the elbow in the direction that the water feed will be coming from. Lock the elbow in position with the grub screw (11) using the 2.5mm hexagonal key.

4.1.6 Before connecting the mixer, water should be flushed through the system to remove all debris.

4.2 Installation (Surface Mounted)



Prior to drilling into walls, check there are no hidden electrical wires, cables or water supply pipes with the aid of an electronic detector. If you use power tools do not forget:

- Wear eye protection
- Unplug equipment after use

4.2.1 Screw the backplate (3) to the wall with screws (2) and wall plugs (1). If the wall is tiled, to avoid the possibility of cracking we recommend that the end of the plug (1) be sunk below the tile and the gap filled with silicon sealant.

With hot supply on the left, cold on the right, when viewed from the front. (A removable red label indicates hot inlet and the 'Bristan' logo should be on the top of the valve body after installation).

4.2.2 Position the elbow concealing plates (5) onto the inlet nut (6) and place the nuts (6) and olives (7) onto the exposed 15mm supply pipes.

4.2.3 Fit the body (30) onto the backplate (3) engaging the 15mm pipes into the elbows (9) and tighten the nuts (6). Lock the body in position by tightening the grub screws (4) using the 3mm hexagonal key.

4.2.4 If a top outlet is required use the maintenance tool (29) to remove the outlet (36) from the shower and using the 6mm hexagonal key to remove the planking plug (37). Refit the outlet (36) into the top of the shower and fit the blanking plug (37) into the bottom of the shower.

4.3 Installation (Recessed)

It is recommended that when installing the valve in a recessed situation, full access is provided for servicing purposes. The plate can be used as a template by drawing a round the plate and measuring in by 15mm to give sufficient clearance.

4.3.1 Secure the backplate (26) into the wall cavity with the screws (2) provided.

4.3.2 Fit the body (30) into the backplate and lock in position using the grub screws (4) with the 3mm hexagonal key.

4.3.3 Engage the 15mm supply pipes (not supplied) into the elbows (9) and tighten the nuts (12) ensuring that the olives (7) are in place.

4.3.4 There are two methods of fixing the wall outlet or the shower arm depending upon the type of wall: (See Over)

4.4 Installation (Wall Outlet)

4.4.1 The simplest method is to connect to the shower a wall-plate elbow (not supplied) which can be secured within the wall, then simply screw in the brass nipple (32) with a suitable thread sealant leaving between 5 to 15mm of thread protruding from the finished wall. Once the wall has been finished the wall outlet (35) can then be fitted to the brass nipple (32) (with a suitable thread sealant) with the rubber gasket (34) fitted behind (Part 33 not required).

4.4.2 The other method is only suitable if you have got access to the fitting once the wall has been finished. Fit the washer (33) to the inlet of the wall outlet (35) then screw the brass nipple (32) to the wall outlet (35). Fit the rubber gasket (34) to the back of the wall outlet and place the assembled wall outlet through a hole (25mm – 30mm) in the wall and secure with the backnut (31). Then connect the wall outlet assembly to the shower valve.

4.4.5 Prior to fitting the concealing plate (27) the position the flow handle so that the small lever is in line with one of the bulges on the shower valve body then slide the concealing plate onto the shower valve.

4.5 Shower Arm Installation (See Fig. 3)

4.5.1 The arm (65) is most suitable for mounting via the backnut (68) and the locking nut (67) either side of the panel and tiles. However it is possible to support the arm using rigid pipe work/wall-plate elbow without using the locking nut (67) and the back nut (68). Slide the cover plate (66) to the wall. Fit the rubber washer (60) in to the inlet of the shower head (69) and fit the shower head to the fixed arm (65)

4.6 Adjustable Riser Installation (See Fig. 2)



Prior to drilling into walls, check there are no hidden electrical wires, cables or water supply pipes with the aid of an electronic detector. If you use power tools do not forget:

- Wear eye protection
- Unplug equipment after use

4.6.1 Use the riser tube (55) assembled with the wall brackets (50) and use the rail as a template to mark out the position of the required mounting holes. Before drilling ensure that the handset (61) will reach the slider (56) when it is in the extreme position. Drill holes to suit the wall plugs (51) if required.

4.6.2 Remove wall brackets (50) slide the slider (56), soap tray (58) and the hose retaining ring (57) on to the tube (55). Re-fit the rail to the wall brackets.

4.6.3 Secure the wall brackets (50) and rail (55) to the wall using the supplied fixing screws (51 & 53), and fit the wall bracket ends (52) and the rail end caps (54). Connect the conical end of the hose (59) to the handset (61), using a small sealing washer (60).

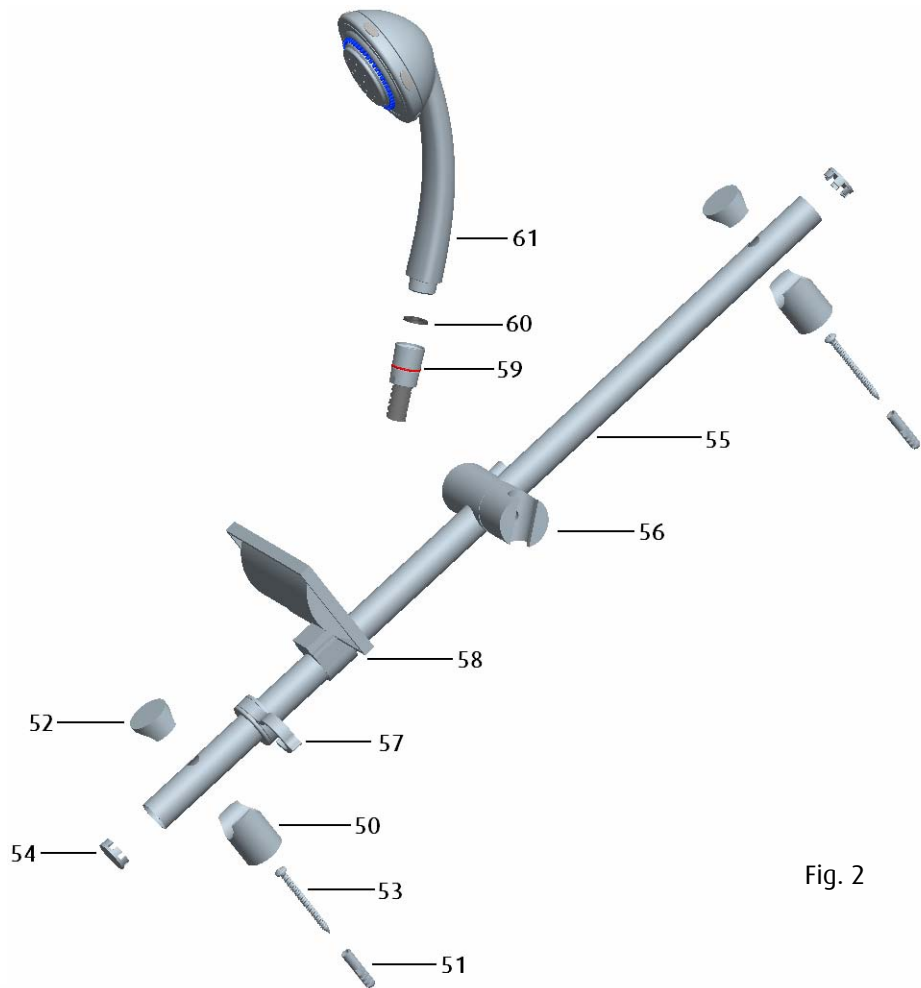

Fig. 2

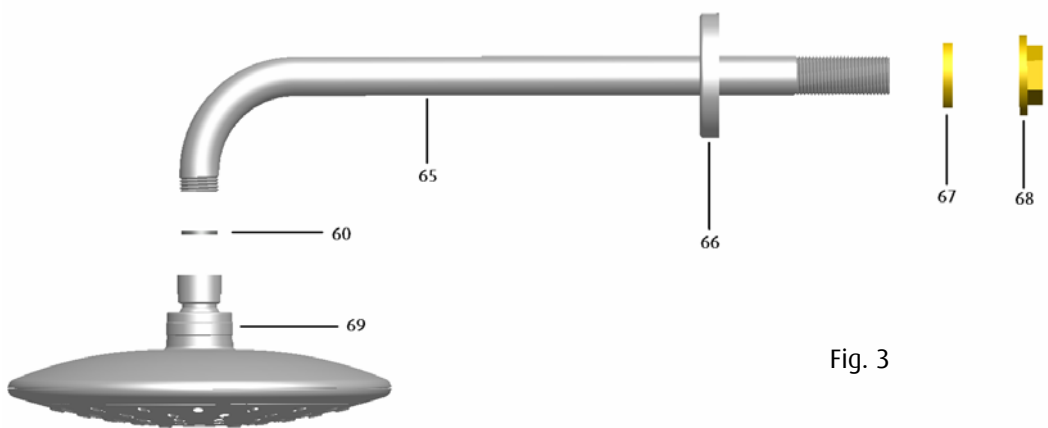

Fig. 3

4.6.4 Feed the free end of the shower hose through the hose retainer (57) and depending on the installation connect the hose to either the wall outlet or directly to the shower valve using the second small sealing washer (60).

5. Setting

5.1 Turn on the water supplies and fully open the flow control, let the water run long enough to ensure that the hot water supply is at its maximum temperature.

5.2 Turn the temperature control anti-clockwise to its maximum position and check the outlet temperature. This has been factory set at 42°C at balanced supply pressures (0.5 bar).

5.3 The maximum temperature can be adjusted to suit site conditions or user preference. To adjust this, follow this procedure:

5.4 See Fig. 4 below, remove the temperature control handle, handle ring and shroud (45, 44 & 43) by removing the cap (47), remove the screw (46) and pulling the handle, handle ring and shroud (45, 44 & 43) off the spindle (A).

5.5 Turn the spindle (A) anti-clockwise to increase the temperature and clockwise to reduce it.

5.6 Refit the handle, handle ring and shroud (45, 44 & 43) so that the stop pin is at the maximum position then refit the screw (46) and replace cap (47).

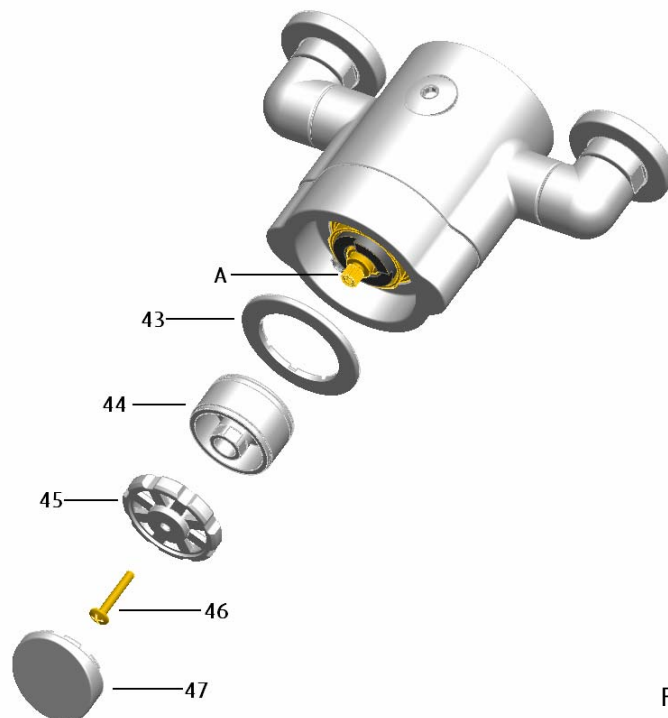

Fig. 4

6. Operation

6.1 On / Off - Flow Control

It is important to note that the flow control handle (39) turns through approximately 170 degrees to achieve full and maximum flow anticlockwise on, clockwise off .

Do not attempt to force the handle past this position as this may cause damage to the valve.

6.2 Temperature Control

The small handle (44) controls the temperature. This control stays stationary when the flow control handle is turned.

To adjust the temperature, turn the control anti-clockwise to increase the temperature and clockwise to reduce it.

The valve automatically adjusts for changes in supply temperature and maintains the outlet at the set temperature.

7. General Fault Diagnosis

7.1 If your valve fails to function correctly, the following should be checked:

7.1.1 Check that the hot and cold connections are the correct way around. Hot on the left, cold on the right when viewed from the front.

7.1.2 Ensure that the hot water temperature is adequate. The recommended minimum temperature is 60°C.

7.2 If your shower will not turn off:

7.2.1 Check hot and cold inlet valves (13) are free of debris (See 8.7 on page 13).

7.3 If your shower has a low flow rate:

7.3.1 Check that the filters (14 &15) are not blocked (See 8.6 on page 13).

8. Cleaning & Maintenance

8.1 Cleaning

Your fitting has a high quality finish and should be treated with care to preserve the visible surfaces.

All surface finishes will wear if not cleaned correctly, the only safe way to clean your mixer is to wipe with a soft damp cloth. Stains can be removed using washing up liquid. All bath cleaning powders and liquids will damage the surface of your fitting, even the non-scratch cleaners.

8.2 Regular Maintenance

We advise that the valve is regularly serviced, particularly in hard water areas. It is also important to clean the handset regularly in hard water areas to maintain an even spray/flow of water.

Please Note: The maintenance procedures detailed in sections 8.3, 8.4, 8.5, 8.6 and 8.8 can be done without isolating the water supplies to the shower.

8.3 Cartridge Removal (See Fig. 5).

8.3.1 Remove the temperature control handle, handle ring and shroud (45, 44 & 43) by removing the cap (47) and the screw (46) and pulling the handle off the spindle of the cartridge (22).

8.3.2 Unscrew the two handle retaining screws (40) and pull the flow control handle (39) off the valve.

8.3.3 Unscrew the retaining nut (25) and remove the slip ring (24), cam (23) and the temperature stop ring (41).

8.3.4 Unscrew the cartridge (22) anticlockwise to remove from the shower body (30).

8.4 Cartridge Maintenance

8.4.1 Place the cartridge (22) in a bowl and carefully add some hot water (just off the boil) and vinegar to de-scale the cartridge. Leave until the water has cooled.

8.4.2 Then remove the cartridge and rinse with clean water.

8.5 Refitting the Cartridge

8.5.1 Grease the seals with silicon grease and carefully refit the cartridge into the body.

8.5.2 Refit the cam (23) slip ring (24) and the retaining nut (25). Refit the temperature stop (41) with the raised section between 9 O'clock and 12 O'clock.

8.5.3 Refit the flow control handle (39) to the cam (23) and secure with the 2 screws (40).

8.5.4 Reset the maximum temperature and refit temperature control handle (see 8.8 on page 14)

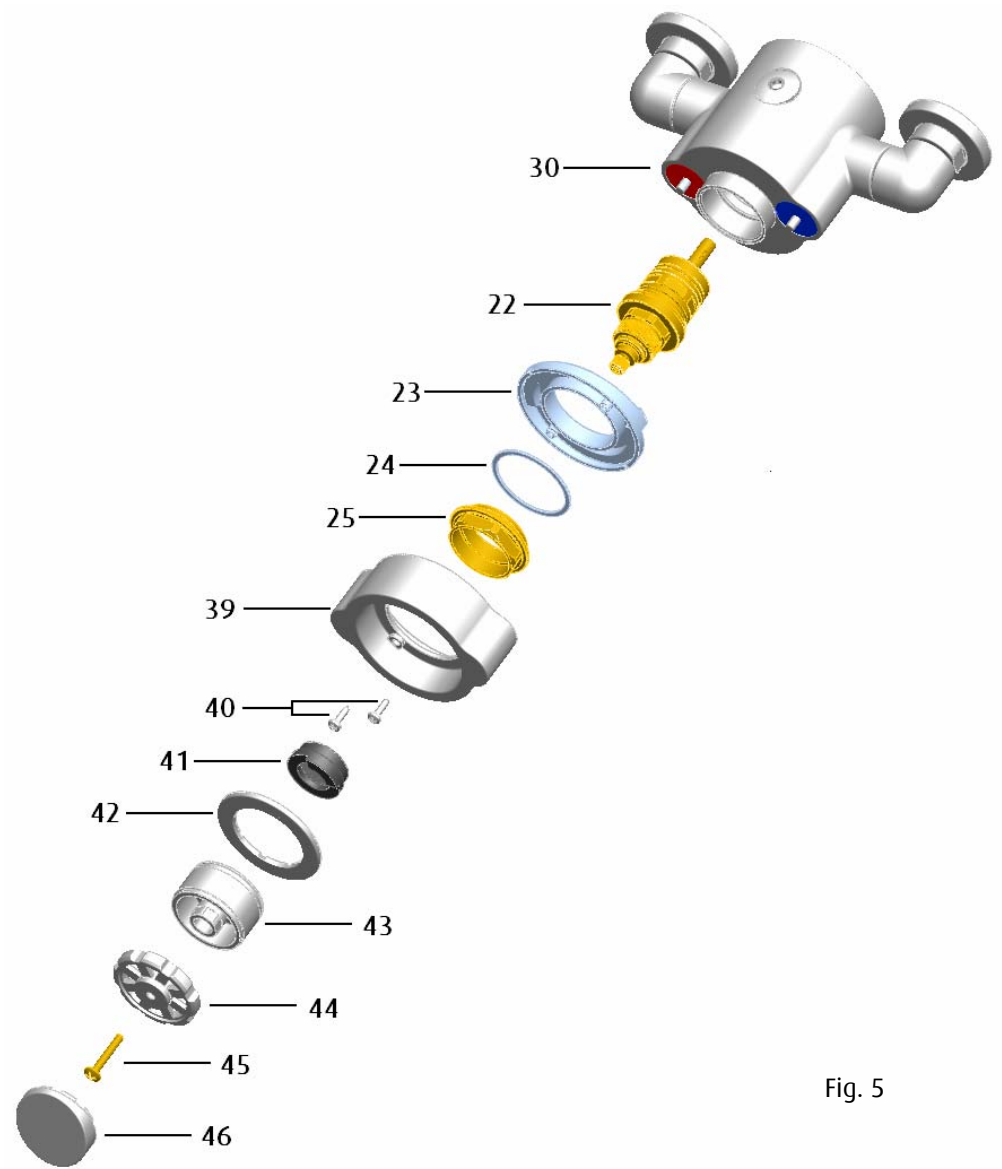

Fig. 5

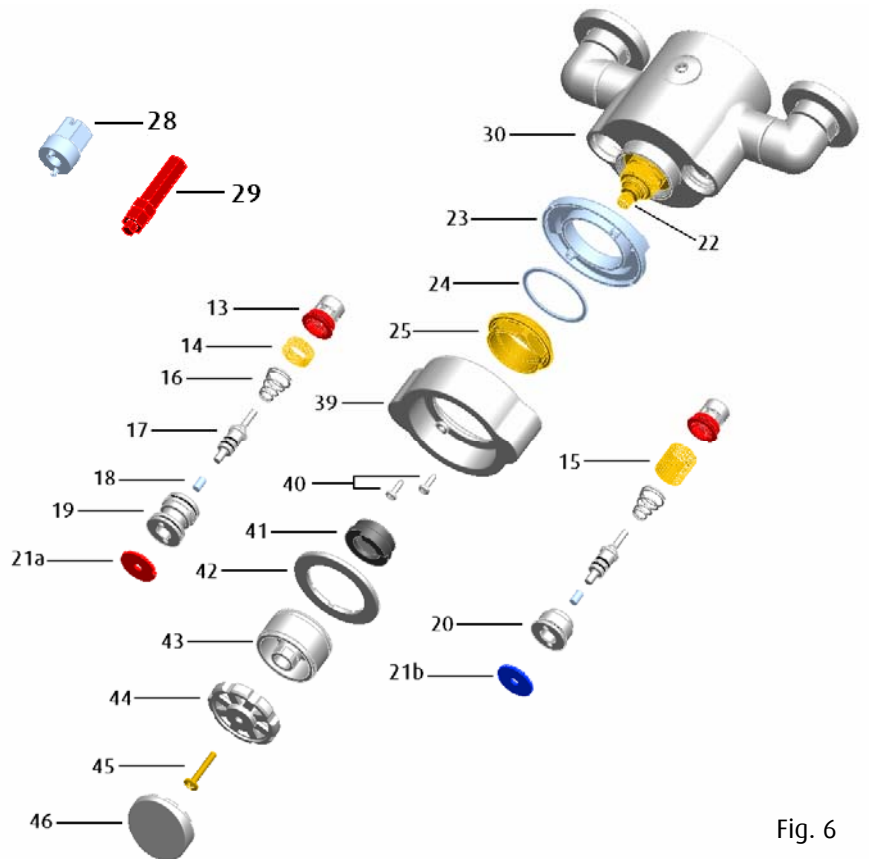

Fig. 6

8.6 Cleaning the Filters (See Fig. 6)

8.6.1 With the handles and cam removed, prise out the blue and red caps (21a & 21b) and unscrew the pin guides (19 & 20) with the maintenance tool (28). Remove the pins (17) and the caps (18), springs (16) and the filters (14 & 15).

8.6.2 Clean the filters and reassemble ensuring any debris is flushed from the body.

8.7 Flow Valve Maintenance (See Fig. 6)

IMPORTANT NOTE: ISOLATE THE WATER SUPPLY TO THE SHOWER VALVE TO CARRY OUT THIS PROCEDURE.

8.7.1 With the handles and filters removed. Unscrew the valves (13) with the maintenance tool (29) or a 10mm hexagonal key (Not Supplied).

8.7.2 Clean the valve seating washers, check that the valves are moving freely and reassemble.

8.8 Resetting the Maximum Temperature (See Fig. 7)

8.8.1 Turn on the water supplies and fully open the flow control, let the water run long enough to ensure that the hot water supply is at its maximum temperature.

8.8.2 See Fig. 7 below, remove the temperature control handle, handle ring and shroud (45, 44 & 43) by removing the cap (47), remove the screw (46) and pulling the handle, handle ring and shroud (45, 44 & 43) off the spindle (A).

8.8.3 Turn the spindle (A) anti-clockwise to increase the temperature and clockwise to reduce it and set to preferred maximum temperature setting.

8.8.4 Refit the handle, handle ring and shroud (45, 44 & 43) so that the stop pin is at the maximum position then refit the screw (46) and cap (47).

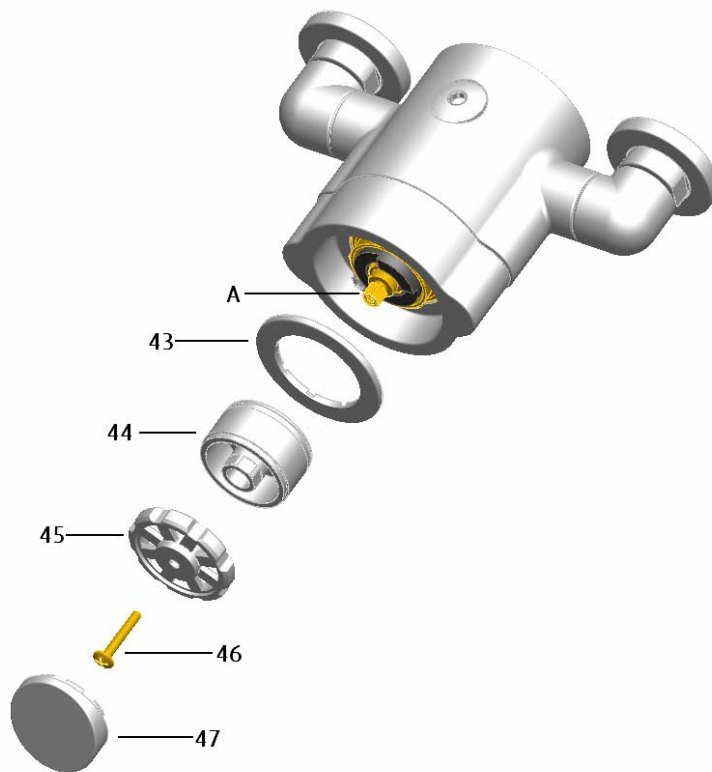

Fig. 7

9. Guarantee & Registration

9.1 Guarantee

All products are manufactured to the highest standards and 5-year guarantee covers any defect in manufacture.

Any part found to be defective during the above guarantee period will be replaced without charge providing that the product has been installed in accordance with our instructions, used as intended and maintained/serviced as recommended.

In the unlikely event that any problems are encountered with this product's performance on installation, you must obtain guidance/authorisation from our Customer Service Department before any remedial action is taken and be able to supply proof and date of purchase.

The guarantee excludes damage caused by accident, misuse or neglect and does not cover the following: Those components subject to wear and tear such as 'O' rings and washers etc,

- Damage caused by faulty installation,
- Damage caused by any waterborne debris,
- Damage caused by improper cleaning products,
- Damage caused by the use of non-Bristan parts,
- The product being used for a purpose other than intended.

The company reserves the right, in the event of a claim not covered by the guarantee, to charge the claimant for parts and labour at current rates. This guarantee is given in addition to and does not affect your statutory rights.

In the interests of continuous product development Bristan Limited reserve the right to alter the specification as necessary.

9.2 Registration

To register your product with us please complete and return the enclosed registration card.

PRODUCT CODE: BZ CSHUAR C, BZ CSHCFH C

TELEPHONE HELP LINE! +44 (0)870 442 5553

Bristan Group Limited
Birch Coppice Business Park
Dordon
Tamworth
Staffordshire
B78 1SG
UK

A Masco Company

Web Site: www.bristan.com
Telephone: +44 (0)870 442 5556
Facsimile: +44 (0)870 442 5554
Email: enquire@bristan.com

(FI BZ CSHW)

(Rev.D1)

(MZ)