

AFTERCARE INSTRUCTIONS

Your fitting has a high quality finish and should be treated with care to preserve the visible surfaces. All surface finishes will wear if not cleaned correctly, the only safe way to clean your mixer is to wipe with a soft damp cloth. Stains can be removed using washing up liquid. All bath cleaning powders and liquids will damage the surface of your fitting - even non-scratch cleaners.

GUARANTEE

All products are manufactured to the highest standards and a 5 year guarantee covers any defect in manufacture.

NOTE: The 5 year guarantee on the valves is invalidated if damaged by any waterborne debris.

In the interests of continuous product development we reserve the right to alter specification as necessary

PRODUCT CODE: JU PBF C

TELEPHONE HELPLINE: 0844 701 6273

Bristan Group Ltd
Birch Coppice Business Park
Dordon
Tamworth
Staffordshire
B78 1SG
UK

Web Site: www.bristan.com
Telephone: 0844 703 6273
Facsimile: 0844 701 6275
Email: enquire@bristan.com

(FI JU PBF)

(Rev. D3)

(KE)

Jute Pillar Bath Filler

Fitting Instructions & Contents List

Please keep these instructions for future reference and for the ordering of spare parts.

(FI JU PBF)

(Rev. D3)

(KE)

WATER PRESSURE

This mixer is suitable for use at all supply pressures. However for optimum, both the hot and cold supplies should be reasonably balanced.

If the fitting is installed at low pressure (tank fed), then the minimum height from the outlet of the nozzle to the underside of the cold tank should be 2 metres to ensure adequate performance.

This mixer should be installed in compliance with Water Regulations. For further details contact your Local Water Authority.

CONTENTS

- 1. Mixer Body (x1)
- 2. Rubber Washers (x2)
- 3. Backnut (x2)
- a. Valve (x2)
- b. Handle (x2)

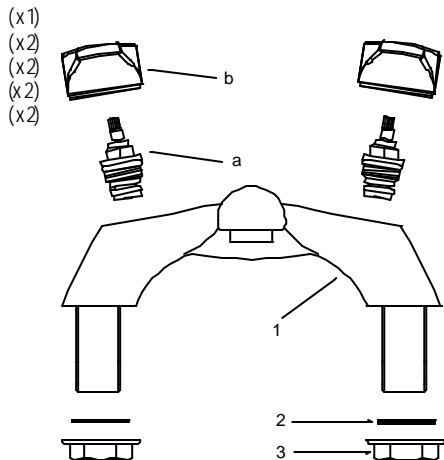

INSTALLATION

1. Identify all components and check for completeness, particularly before arranging fitting.
2. Install the mixer body (1) to the bath using the washers (2) and backnuts (3) provided.
3. Connect the hot and cold water supplies.
4. Turn on the water supplies. Turn on both hot and cold taps for a few minutes letting the water flow, to check all joints and connections for leaks.
5. See over the page for aftercare instructions.

MAINTENANCE

If the fitting begins to drip:

1. Turn off the water supply.
2. Remove grub screws from rear of handle and then remove handle (b) by pulling from valve (a).
3. Using a suitable spanner, remove valve. Once removed, carefully clean seating, rubber washer and ceramic disc.
4. Replace all of the above then turn on the water supply.
5. If problem persists contact our helpline quoting the product code.

Please Note:

In the unlikely event you find a part missing please contact our Customer Service Help line on 0844 701 6273 or email enquire@bristan.com for immediate despatch of part.