

## AFTERCARE INSTRUCTIONS

Your fitting has a high quality finish and should be treated with care to preserve the visible surfaces. All surface finishes will wear if not cleaned correctly, the only safe way to clean your mixer is to wipe with a soft damp cloth. Stains can be removed using washing up liquid. All bath cleaning powders and liquids will damage the surface of your fitting - even non-scratch cleaners.

## GUARANTEE

All products are manufactured to the highest standards and a 5 year guarantee covers any defect in manufacture.

**NOTE:** The 5 year guarantee on the valves is invalidated if damaged by any waterborne debris.

*In the interests of continuous product development we reserve the right to alter specification as necessary*

**PRODUCT CODE: JU BASNW C**

**TELEPHONE HELP LINE: 0870 4425553**

Bristan Group Ltd  
Birch Coppice Business Park  
Dordon  
Tamworth  
Staffordshire  
B78 1SG  
UK

Web Site: [www.bristan.com](http://www.bristan.com)  
Telephone: 0870 4425556  
Facsimile: 0870 1611002  
Email: [enquire@bristan.com](mailto:enquire@bristan.com)

(FI JU BASNW)

(Rev. D2)

(G)

## Jute Basin Mixer (Without Waste)

## Fitting Instructions & Contents List

**Please keep these instructions for future reference and for the ordering of spare parts.**

## WATER PRESSURE

This mixer is suitable for use at all supply pressures. However for optimum use both the hot and cold supplies should be reasonably balanced.

If the fitting is installed at low pressure (tank fed), then the minimum distance from the outlet of the nozzle to the underside of the cold tank should be approximately 2 metres to ensure adequate performance.

This mixer should be installed in compliance with Water Regulations. Where the supplies are unbalanced, i.e. hot water from the cylinder tank / cold from the mains, approved check valves must be fitted in the supply pipes.

For further details contact your Local Water Authority.

## CONTENTS

- |                      |      |
|----------------------|------|
| 1. Mixer Body        | (x1) |
| 2. Rubber O-Ring     | (x1) |
| 3. Rubber C-Plate    | (x1) |
| 4. Metal C-Plate     | (x1) |
| 5. Copper Tail Pipes | (x2) |
| 6. Threaded Rod      | (x2) |
| 7. Nut               | (x2) |
| a. Cartridge         | (x1) |
| b. Lock Nut          | (x1) |
| c. Shroud            | (x1) |
| d. Handle            | (x1) |
| e. Grub Screw        | (x1) |

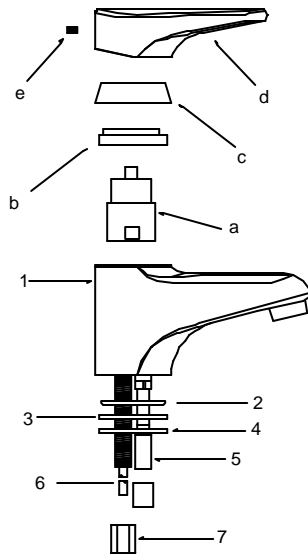

## INSTALLATION

1. Identify all components and check for completeness, particularly before arranging fitting.
2. Install the mixer (1) into the basin. The nut (7) is used to secure the mixer to the surface of basin using the threaded rod (6).
3. Connect the hot and cold water supplies.
4. Turn on the water supplies. Lift and turn handle both ways for a few minutes letting the water flow, to check all joints and connections for leaks.
5. See over the page for aftercare instructions.

## MAINTENANCE

### **If the fitting begins to drip:**

1. Turn off the water supply.
2. Remove grub screw (e) and then remove handle (d) by pulling from cartridge (a). Unscrew both shroud (c) and lock nut (b).
3. Using a suitable spanner, remove cartridge. Once removed, carefully clean seating and exposed parts.
4. Replace all of the above then turn on the water supply.
5. If problem persists contact our helpline quoting the product code.

### **Please Note:**

In the unlikely event you find a part missing please contact our Customer Service Help line on 0870 4425553 or email [enquire@bristan.com](mailto:enquire@bristan.com) for immediate despatch of part.