

BRISTAN

Installation Instructions

Vantage Basin Taps With Cross Head Handles

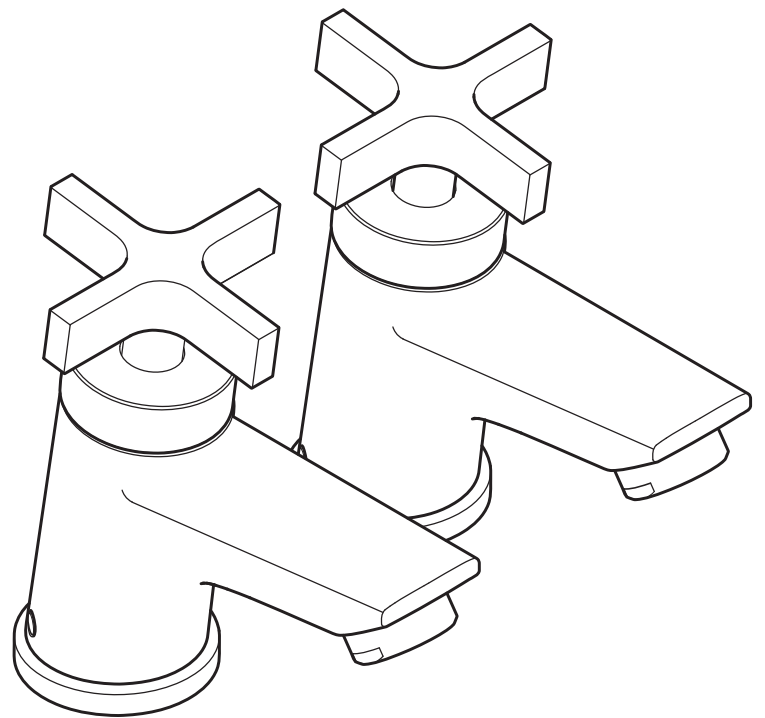

Models covered: VTX 1/2 C

Please keep this booklet for future reference.

Installer, when you have read these instructions please ensure you leave them with the user.



Contents

Thank you for choosing Bristan, the UK's leading taps and showers expert.

We have designed this product with your enjoyment in mind. To ensure that it works to its full potential, it needs to be fitted correctly. These fitting instructions have been created to give you all of the information you need and, if you need any further help, please do not hesitate to contact us.

Important Safety Information.....	3
General Information	4
Pack Contents	5
Product Features.....	6
Specifications	7
Dimensions.....	8
Installation Requirements	9
Installation.....	10-11
Maintenance	12
Troubleshooting.....	13
Guarantee	14-15

Important Safety Information

- Please read these instructions thoroughly and retain for future use.
 - All products manufactured and supplied by Bristan are safe provided they are installed, used correctly and receive regular maintenance in accordance with these instructions.
 - **If you are in any doubt about your ability to install this product safely you must employ the services of an experienced qualified plumber.**
 - This fitting needs to be installed in accordance with, and meet the requirements of the Water Supply (Water Fittings) Regulations 1999 and Scottish Byelaws 2004.
 - Remove all packaging and check the fitting for damage before starting installation.
 -  **Warning:** Before starting any installation please consider the following: before drilling into walls, check that there are no hidden electrical wires, cables or water supply pipes. This can be checked with the aid of an electronic detector.
 - If power tools are used do not forget to:
 - Wear eye protection
 - Unplug equipment after use
 - **Important:** Remember to turn off the mains water supply before connecting to any existing pipe work. Fitting isolating valves to the inlet feeds is recommended for ease of maintenance.
 -  **Warning:** Before installing the new fitting it is essential that you thoroughly flush through the pipework in order to remove any remaining swarf, solder, etc. Failure to carry out this procedure could cause problems or damage to the workings of the fitting.
 - Take care when handling the 'flexible connecting pipes', do not bend, twist or crush them. Only tighten the pipes by hand.
 - Do not crush or kink the shower hose, this could damage the hose and cause leaks.
 - Your fitting has a high quality finish and should be treated with care to preserve the visible surfaces. All surfaces will wear if not cleaned correctly, the only safe way to clean your fitting is to wipe with a soft damp cloth. Stains can be removed using washing up liquid. All bath cleaning powders and liquids will damage the surface of your fitting, even the non-scratch cleaners.
- Note:** Never use abrasive detergents or disinfectants or those containing alcohol, hydrochloric acid or phosphoric acid.

General Information

Operating pressure range: Minimum 0.2 bar, Maximum 5.0 bar.

Maximum static pressure: 10.0 bar.

Designed to comply with BS EN 200 for single taps, for water systems of type 1 and 2 general technical specifications and to be used within systems designed to BS 6700.

BS 6700 recommends the temperature of stored water should never exceed 65°C. A stored water temperature of 60°C is considered sufficient to meet all normal requirements and will minimise the build up of lime scale in hard water areas.

If the fitting is installed at low pressure (tank fed), then the minimum distance from the highest installed position of the outlet to the underside of the cold tank should be at least 2 metres to ensure adequate performance.

These taps and mixers should be installed in compliance with the Water Regulations. Where the supplies are unbalanced, i.e. Hot water from cylinder tank / cold from the mains, approved check valves must be fitted in the supply pipes.

For further details contact your Local Water Authority.

Pack Contents

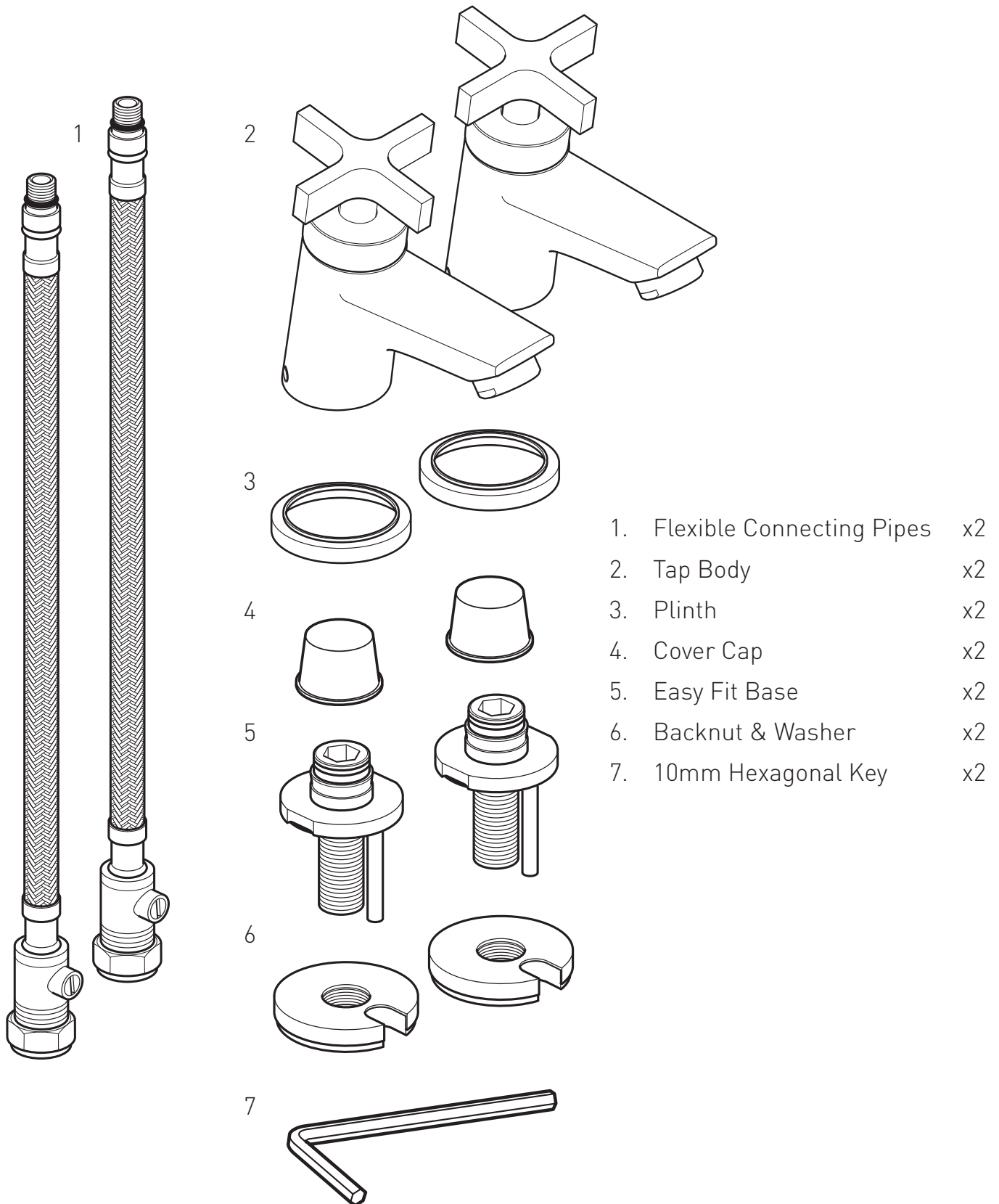

Product Features

Cross Head Handles

Easy to use 1/4 turn cross head handles make operating the taps easy when the users hands are wet.

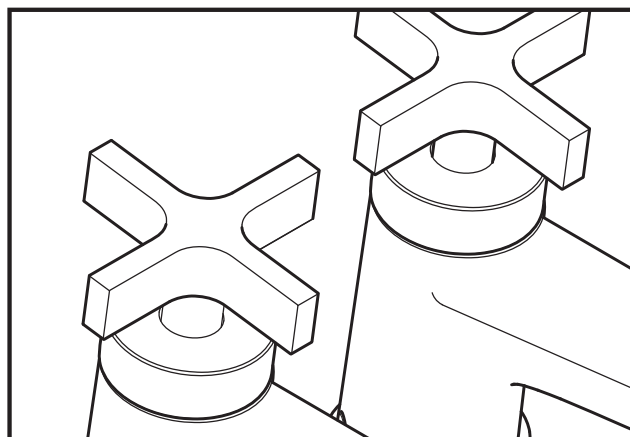

Built in Isolation Valves

Both flexible connecting pipes come with built in isolation valves, making servicing and maintenance quick and easy.

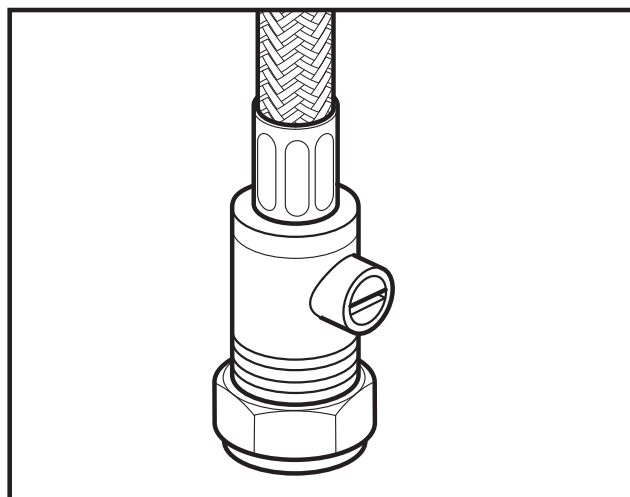

Easy Fit Base

A unique patented easy fit base makes fitting the tap bodies simple, quick and easy for the installer.

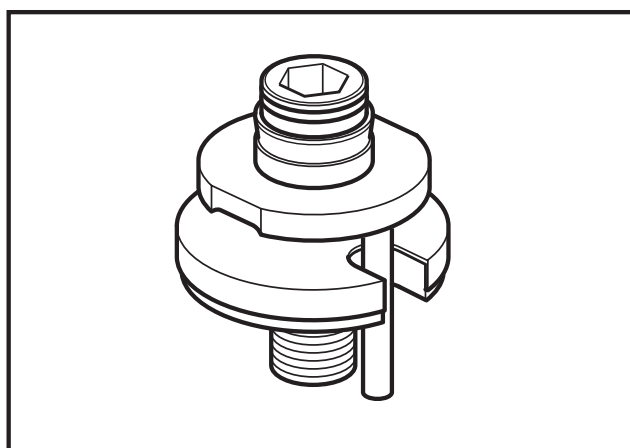

Specifications

Inlet Connections: 15mm Compression fitting with integral isolation valve

Minimum working pressure: 0.2 bar

Maximum working pressure: 5.0 bar

Maximum static pressure: 10.0 bar

System Requirements:

Gravity fed hot & cold (Equal pressures)

Gravity fed hot & cold (Differential pressure, maximum ratio 5:1)

Unvented systems

Instantaneous water heater (Combination boiler)

 **Important:** To ensure the tap fittings are securely fastened to the basin we recommend the relevant torque setting (table shown below) is applied to the 'Push-fit connector' when tightening to the back nuts.

Fitting	Torque
Basin Taps	20 - 25 Nm

Patent Applications	PCT/GB2011/051010
	TW100118586

These fittings need to be installed in accordance with the following Installation Requirements and Notes (IRN) to ensure they meet the requirements of the Water Supply (Water Fittings) Regulations 1999 and the Scottish Byelaws 2004.

IRN R001

See text of entry for Installation Requirements or Notes.

IRN R006

This tap or combination tap assembly has a Type AUK3 air gap and is therefore for installation in any premises to protect against a backflow risk up to a Fluid Category 5.

Dimensions

Dimensions are nominal and in millimetres.

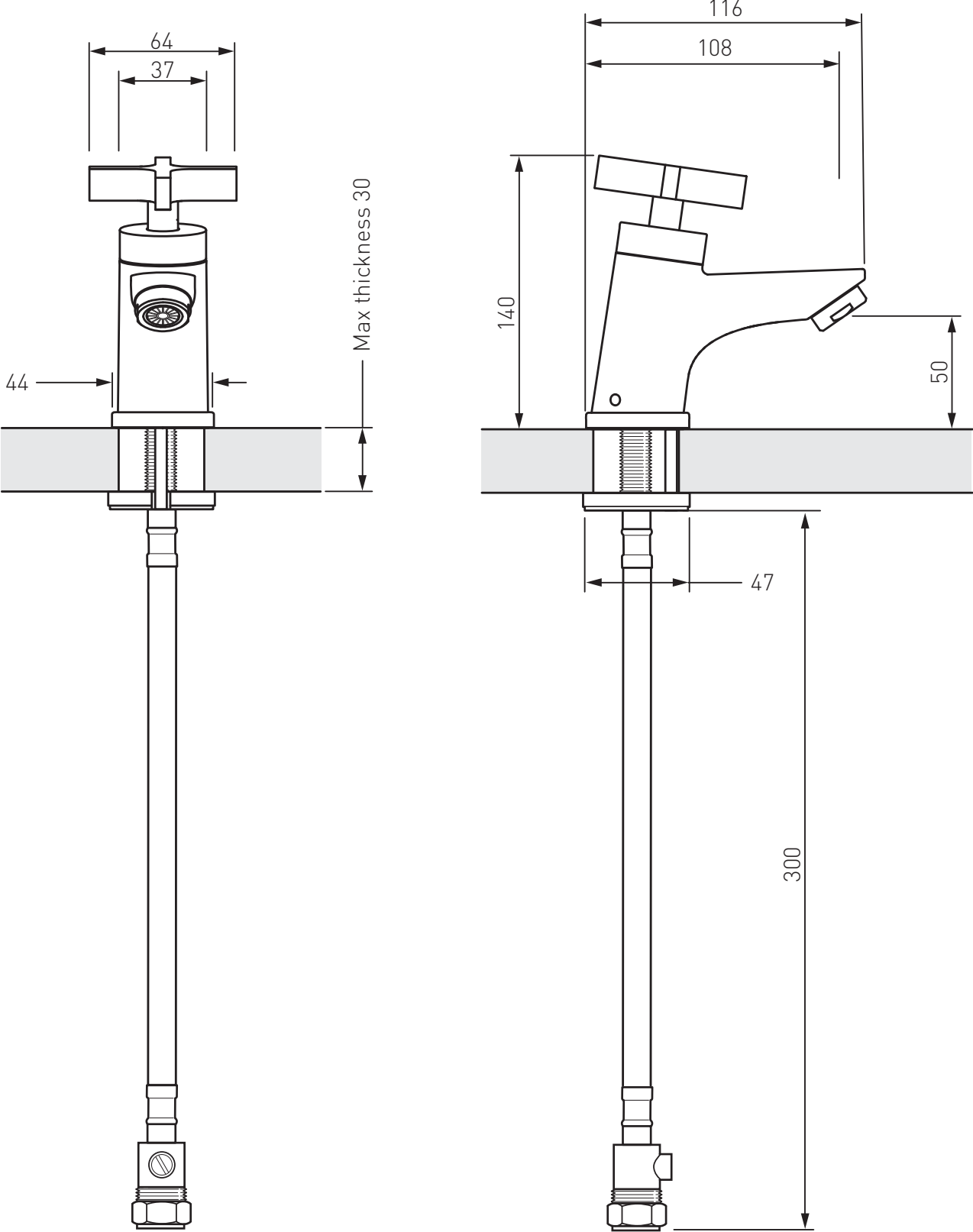

15mm Compression fitting with integral isolation valve

Installation Requirements

Flexible Connecting Pipes

Care must be taken when connecting the flexible connection pipes to the household pipework to ensure they do not bend sharply and kink or twist.

See below for recommended ways to fit the flexible connecting pipes.

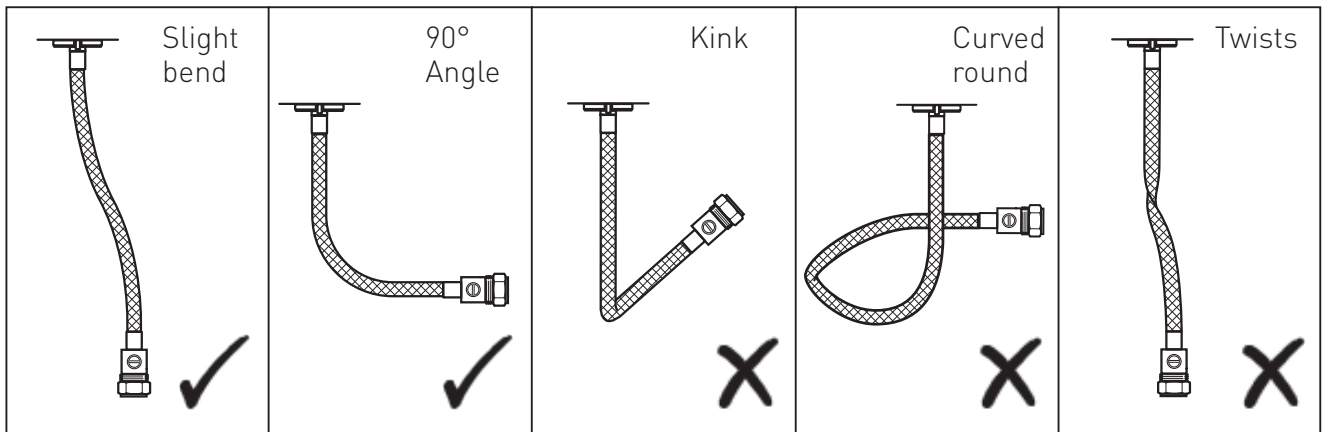

⚠ Important: Failure to follow these guidelines may result in poor performance and damage to the flexible connecting pipes.

The Integral Isolation Valves

The integral isolation valves must be accessible with a suitable flatblade screwdriver for turning on and for future servicing purposes.

See below for the off and on positions of the isolation valves.

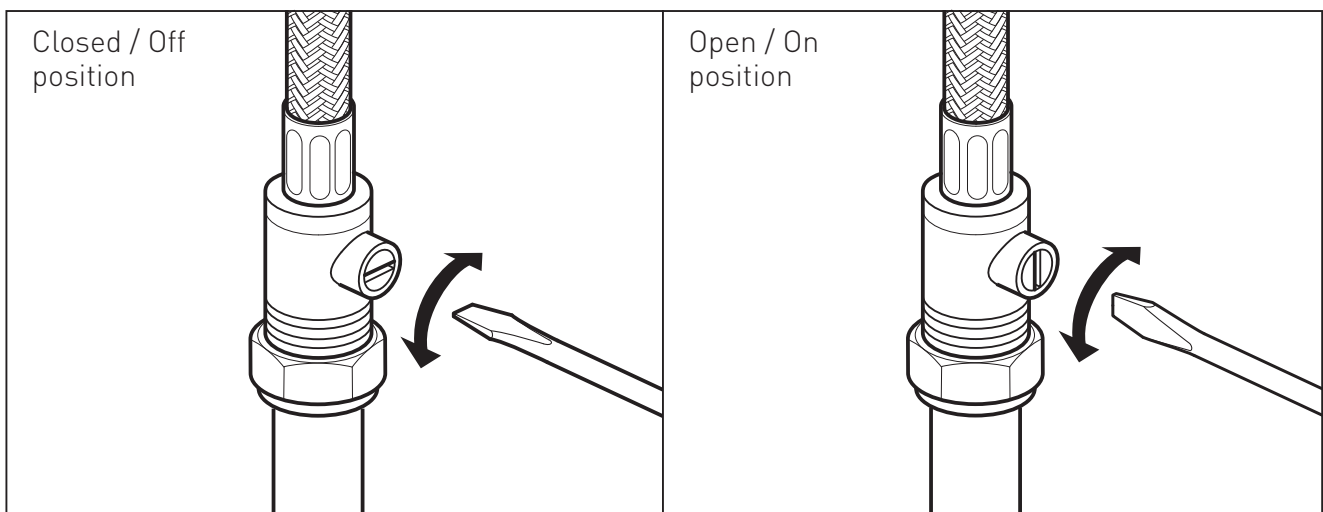

Installation

Before installation

Flush through the pipework to ensure removal of debris. Turn off mains water supply and close any isolating valves.

1. Attach push-fit connectors

Place the 'push-fit connectors' into the holes in the basin top, ensure the rubber 'O' ring is fitted to the underside.

Position the 'back nuts' under the basin (with rubber seal on top), ensuring the locating pin fits into the cut-out in the back nuts. Tighten by turning the 10mm hexagonal key clockwise, once threading has started you can let go of the back nuts.

⚠ Important: The push-fit connectors must be fully tightened to the back nuts before attaching the flexible connecting pipes.

2. Attach flexible connecting pipes

⚠ Important: Before connecting the flexible connecting pipes, please refer to the specific installation requirements on page 6.

Carefully screw the 'flexible connecting pipes' into the 'push-fit connectors' and turn the integral isolation valves to the 'closed' position as shown on page 6.

⚠ Important: Only tighten the flexible connecting pipes by hand. **Do not overtighten.**

Connect the flexible connecting pipes to the household water supply pipes.

3. Cover cap

If required place the cover caps over the push-fit connectors until the tap body is ready to be fitted.

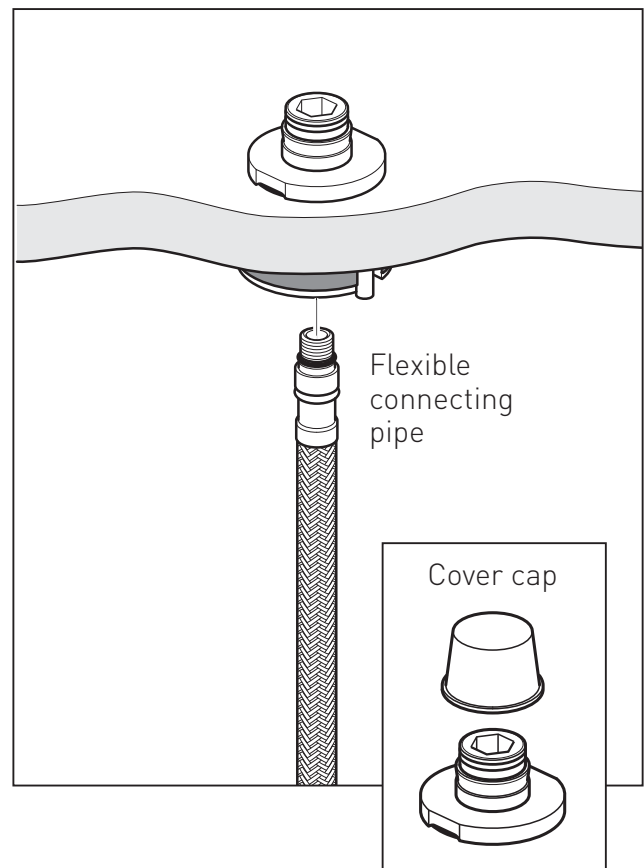
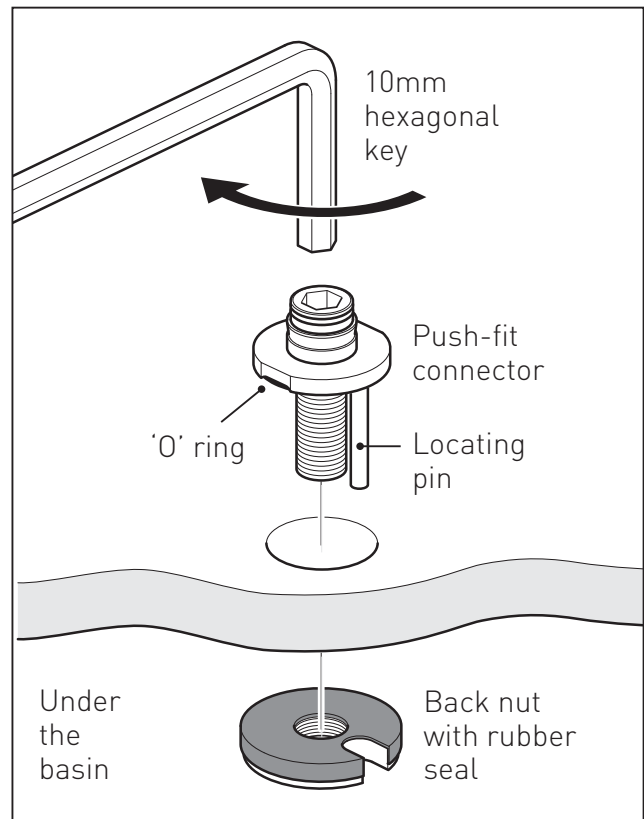

Installation

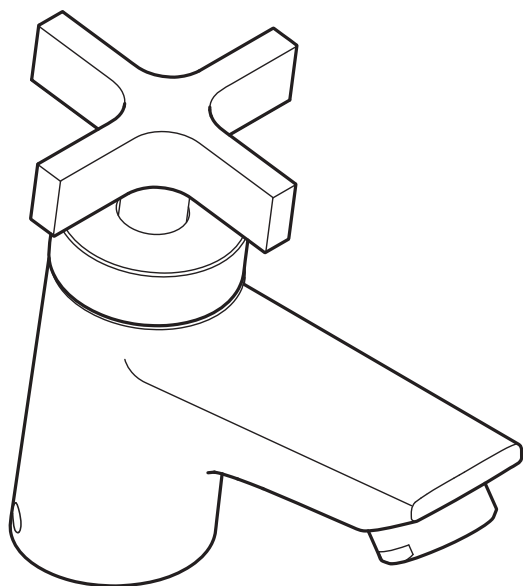

Plinth

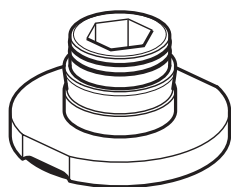

Push-fit connector

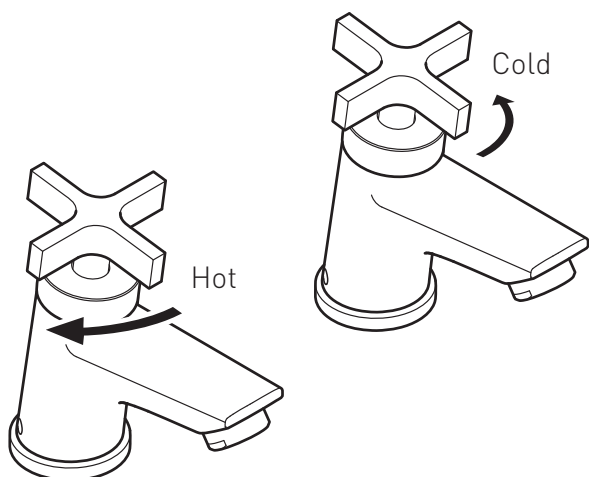

4. Fit the tap body

Remove the cover caps and place the plinths over the push-fit connectors. Grease the push-fit connectors using the sachet of grease provided. Push-fit the tap body onto the connectors.

Align the body and tighten both grub screws at the rear of the body using the long end of the 2.5mm hexagonal key as shown below until finger tight. Remove the hexagonal key and insert the short end into the grub screw and tighten an extra $\frac{3}{4}$ to 1 complete turn more to ensure the tap body is securely tightened to the push-fit connector.

⚠ Important: The fitting must be securely attached to the base.

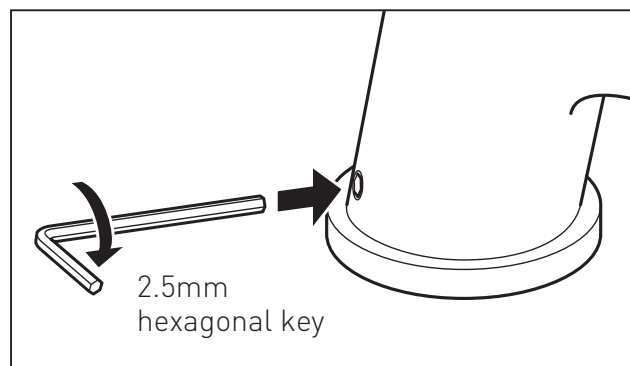

Push-fit the grey rubber plugs into the grub screw holes.

Turn on the mains water supply and open the isolating valves using a suitable flatblade screwdriver.

Operation

Move the hot lever left and the cold lever right to increase the flow of water.

Maintenance

General Cleaning

Your fitting has a high quality finish and should be treated with care to preserve the visible surfaces. All surfaces will wear if not cleaned correctly, the only safe way to clean your mixer is to wipe with a soft damp cloth. Stains can be removed using washing up liquid. All bath cleaning powders and liquids will damage the surface of your fitting, even the non-scratch cleaners.

Note: Never use abrasive detergents or disinfectants or those containing alcohol, hydrochloric acid or phosphoric acid.



Bristan recommend E-cloth for cleaning all of our bathroom & kitchen products. Using just water, E-cloth gives a smear free, deep clean by breaking up and holding dirt, which normal cloths leave behind. Order through your Bristan stockist (order code: ECLOTH).

Cleaning the Valves

Before carrying out any maintenance, turn off the mains water supply and close any isolating valves.

Loosen the grub screw (but do not remove) using a 2.5mm hexagonal key, turning anti-clockwise. Remove the head and unscrew the shroud.

Using the correct size spanner unscrew and remove the valve. Wash the valve with clean running water and make sure that any debris has been removed. Dry and lightly grease the seal (only use silicone grease), replace the valve shroud and head.

! **Important:** Tighten the valve with the correct size spanner and apply appropriate force/torque. **Do not overtighten.**

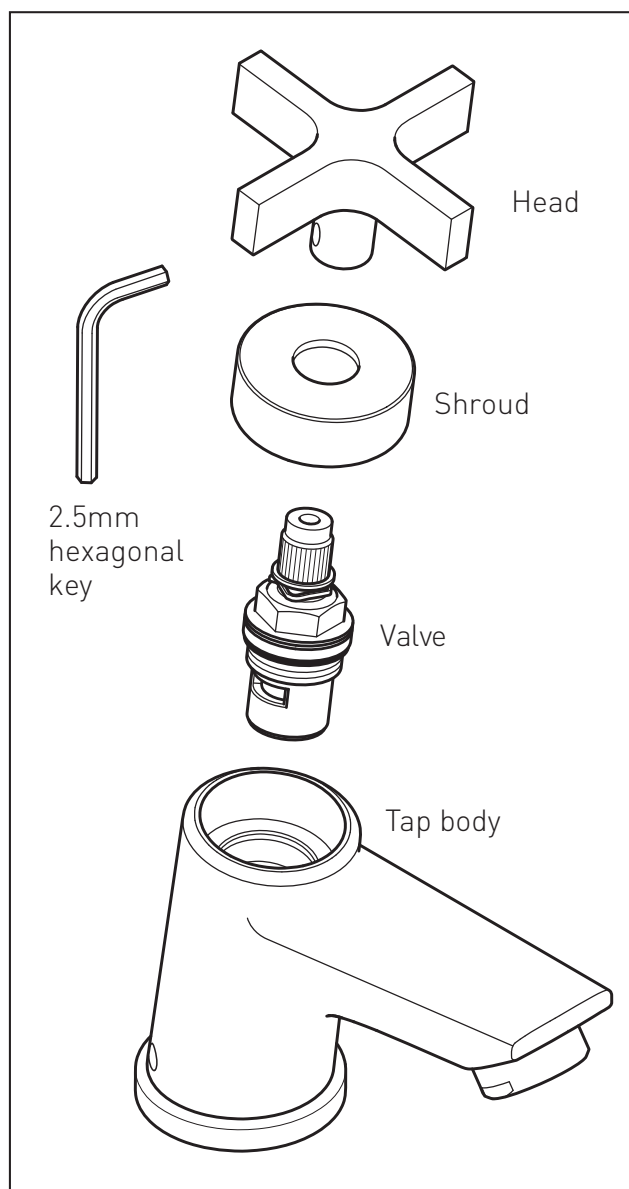

Troubleshooting

Symptom	Cause	Remedy
No flow or low flow rate	partially closed isolation valve.	Open isolation valve.
	Instantaneous water heater cycles on and off as flow rate or pressure is too low.	Increase water flow rate or pressure through system.
	Head of water is below the minimum distance required.	Refer to 'Specification' on page 7.
	Hot or cold water being drawn off elsewhere causing pressure changes or instantaneous boiler temperature changes.	Do not use other water outlets when using the taps.
	Airlock or partial blockage in the supply pipework.	Flush through pipework to ensure removal of debris and any airlocks.
Water dripping from taps	This is normal for a short time after using the taps.	This is caused by capillary action, the build up of water in the tap body.
	If water continues to drip, possibly due to the ceramic disc valves	Remove valves and clean, refer to 'Maintenance' section on page 12 before removing the tap.
Taps do not turn on	Closed isolation valve.	Open isolation valve.
	Mains water supply turned off.	Turn on mains water supply.

Guarantee

At Bristan, we want to make things as easy as possible for our customers. That's why we design products that are easy to fit and use, and that are quality tested to make sure they won't let you down. It's also why we offer solid guarantees on all products, effective from the date of purchase, to give you peace of mind.

Bristan's Bathroom Taps are covered by a **5 year guarantee**. This also includes **5 years labour cover** * (subject to registration) which means that, in the unlikely event that there is a problem in the first year after purchase, we'll send one of our expert engineers to fix it.

*Labour is provided by an approved Bristan Care engineer or appointed representative. The guarantee only applies to products with a manufacturing fault. There will be a call out charge for any incidents where no fault has been found with the product, or if the issue is due to poor installation or maintenance.

Guarantee Terms and Conditions

This guarantee is in addition to your statutory and other legal rights and is subject to the following conditions:

- The product was purchased within the United Kingdom or Republic of Ireland.
- The guarantee applies solely to the original purchaser with proof of purchase.
- The installation must allow ready access to all products for the purpose of inspection, maintenance or replacement.

- Repair under this guarantee does not extend the original expiry date. The guarantee on any replacement parts or product ends at the original expiry date.
- Any part found to be defective during the guarantee period will be replaced without charge, providing that the product has been installed in accordance with the instructions given in this guide and used as the manufacturer intended.

The guarantee does not cover:

- Damage or defects caused by;
 - General wear and tear (including special non-chrome finishes; components such as filters, seals, 'O' rings and washers)
 - Incorrect installation
 - Repair using non-Bristan parts
 - Accidental or wilful misuse
 - Corrosion and the use of inappropriate cleaning products
 - System debris including the build up of limescale (which can be controlled through regular servicing and maintenance)
- Compensation for loss of use of the product or consequential loss of any kind.

In the interests of continuous product improvement, Bristan reserves the right to alter product specifications without notice.

The Bristan Product Guarantee does not affect your statutory rights as a consumer.

Guarantee & Service Policy

• Need help?

If this product does not function correctly when first used, contact **Bristan Care Customer Service on 0844 701 6273** where our expert team of advisors will be able to offer you help and advice.

• Problems during the guarantee period

In the unlikely event that you encounter any problems with the product during the guarantee period, contact **Bristan Care Customer Service on 0844 701 6273** with your proof of purchase and we will work to resolve the problem quickly.

Bristan Care Customer Support

Bristan customers also benefit from the support of Bristan Care, our comprehensive customer support package which offers:

Technical support hotline

(Tel: 0844 701 6273) with access to fully trained advisers who can offer installation advice, talk you through quick maintenance checks, or recommend the best course of action to fix any problems with a product.

Expert advice

Find easy to follow 'how to' video guides and technical FAQs online at www.bristan.com. Our guides take you step-by-step through many product installations and you can find plenty of easy guides to quick product fixes and servicing.

Spare parts

We hold thousands of spares and we keep them for discontinued products for over seven years. Spares can easily be ordered online at www.bristan.com and are dispatched the same day.

Expert plumbing engineers

If we can't solve the problem over the 'phone or with a spare part, then we'll send out one of our Bristan Care engineers to take a look. Bristan Care engineers provide free support for products that are within guarantee, but are also available to service products that are out of guarantee for a small charge. For details, please call **Bristan Care Customer Service on 0844 701 6273**.

Part Number: FI VTX 1/2 C
Issue: D1

BRISTAN

Bristan Group Ltd.
Birch Coppice Business Park
Dordon
Tamworth
Staffordshire
B78 1SG
Web: www.bristan.com
Email: enquire@bristan.com

A Masco Company

Useful contact details:

Customer Service:

0844 7016273

Customer Service Email:

Customercare@bristan.com

Customer Service Fax:

0844 7016275

Reception:

0844 7016274

Join us on...

