

# BRISTAN

## Ebony Extension Tap Range

### Installation Instructions & User Guide

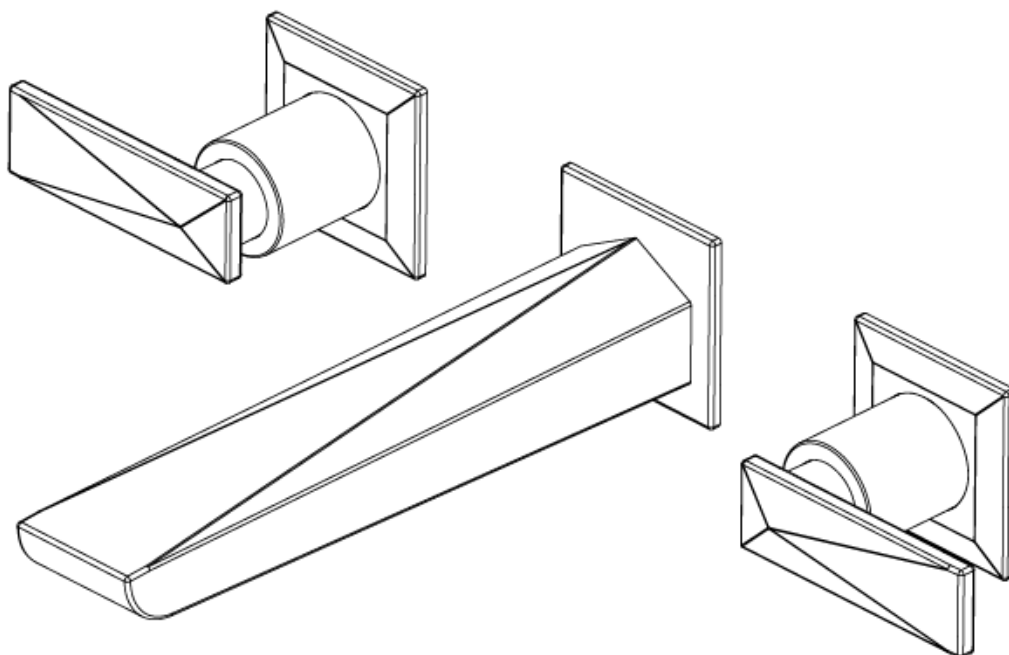

**Please keep these instructions for future reference**

## Contents

Thank you for choosing Bristan, the UK's leading showers and taps expert. We have designed this product with your enjoyment in mind. To ensure that it works to its full potential, it needs to be fitted correctly. These fitting instructions have been created to give you all of the information you need and, if you need any further help, please do not hesitate to give us a call on 0844 701 6273.

|                                                  |       |
|--------------------------------------------------|-------|
| Important Safety Information                     | 03    |
| General Specifications                           | 03    |
| Dimensions                                       | 04-05 |
| Installation                                     | 06-09 |
| 3 Hole Wall Mounted Basin Mixer<br>& Bath Filler | 06-07 |
| Floor Standing Bath Shower Mixer                 | 08-09 |
| Maintenance                                      | 10-12 |
| Troubleshooting                                  | 13    |
| Guarantee                                        | 14-15 |

## Important Safety Information

- Please read these instructions thoroughly and retain for future use.
- All products manufactured and supplied by Bristan are safe provided they are installed correctly, used correctly and receive regular maintenance in accordance with these instructions.
- **If you are in any doubt about your ability to install this product safely you must employ the services of an experienced qualified plumber.**
- Remove all packaging and check the components for damage before starting installation.
-  Before starting any installation please consider the following: Prior to drilling into walls, check that there are no hidden electrical wires, cables or water supply pipes. This can be checked with the aid of an electronic detector.
- If power tools are used do not forget to:
  - Wear eye protection
  - Unplug equipment after use
- This product **must** not be modified in any way as this will invalidate the guarantee.
- These fittings need to be installed in accordance with and meet the requirements of the Water Supply (Water Fittings) Regulations 1999 and Scottish Byelaws 2004.

## General Specifications

| Operating pressure range (bar)     | Min | Max |
|------------------------------------|-----|-----|
| EBY 3HWMBAS C                      | 0.2 | 5.0 |
| EBY 3HWMBF C                       | 0.2 | 5.0 |
| EBY FSBSM C                        | 2.0 | 5.0 |
| Maximum static pressure – 10.0 bar |     |     |

**NOTE:-** Nominally equal (balanced) inlet supply pressures are recommended for optimum Performance of mixer taps.

Designed to comply with BS EN 200 for single taps / combination taps for water systems of type 1 and 2 general technical specifications; and to be used within systems designed to BS 6700.

BS 6700 recommends the temperature of stored water should never exceed 65°C. A stored water temperature of 60°C is considered sufficient to meet all nominal requirements and will minimise the build up of lime scale in hard water areas.

## Dimensions

3 Hole Wall Mounted Basin Mixer

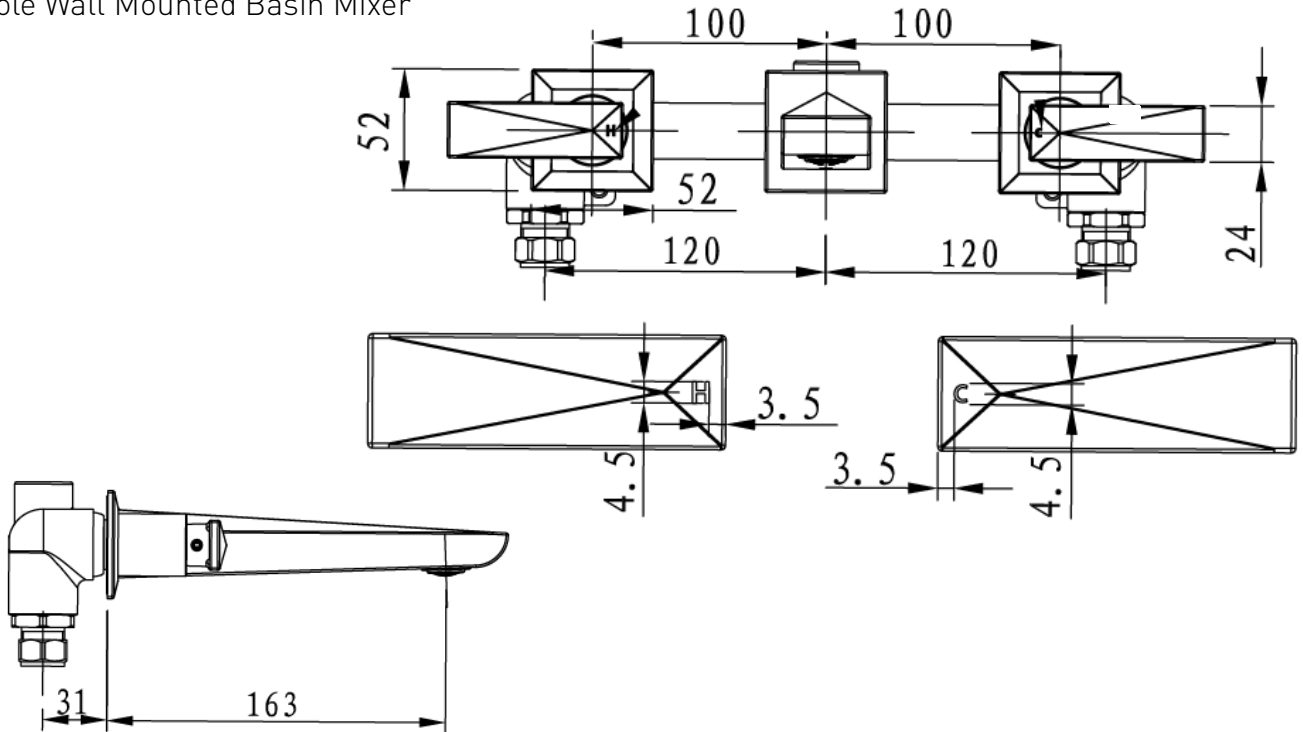

3 Hole Wall Mounted Bath Filler

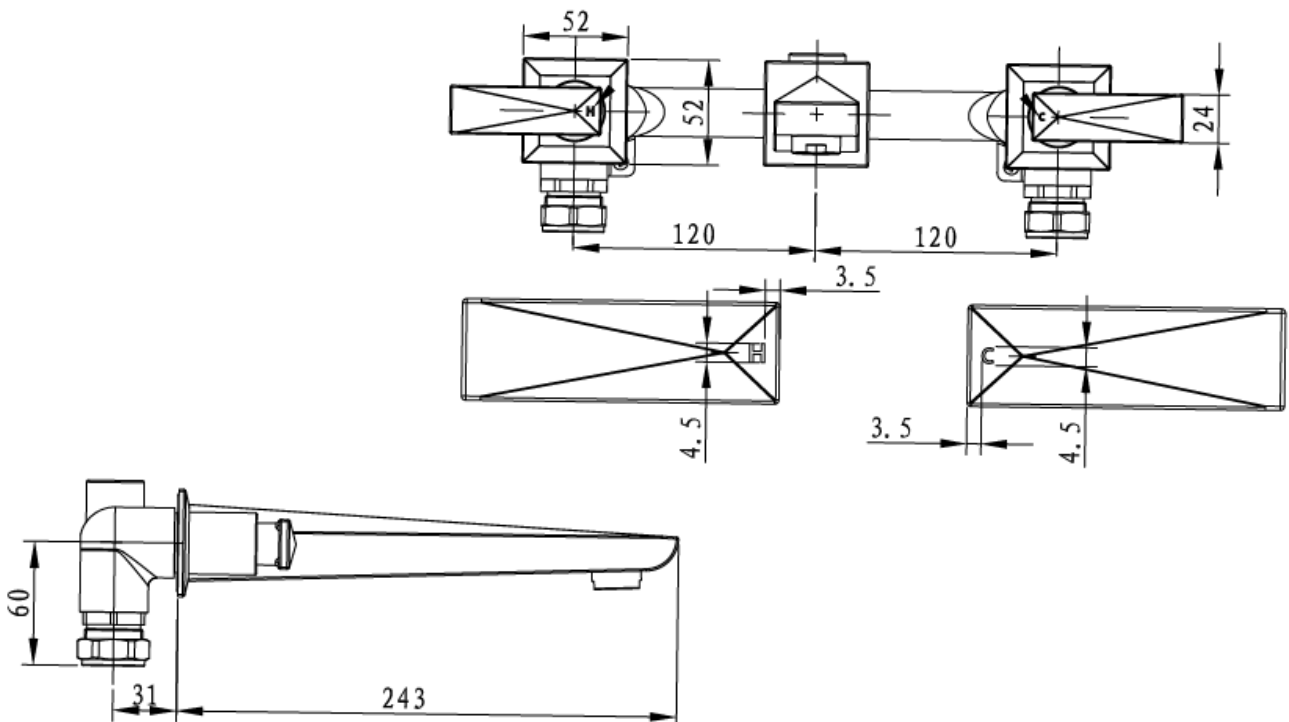

Dimensions Cont.

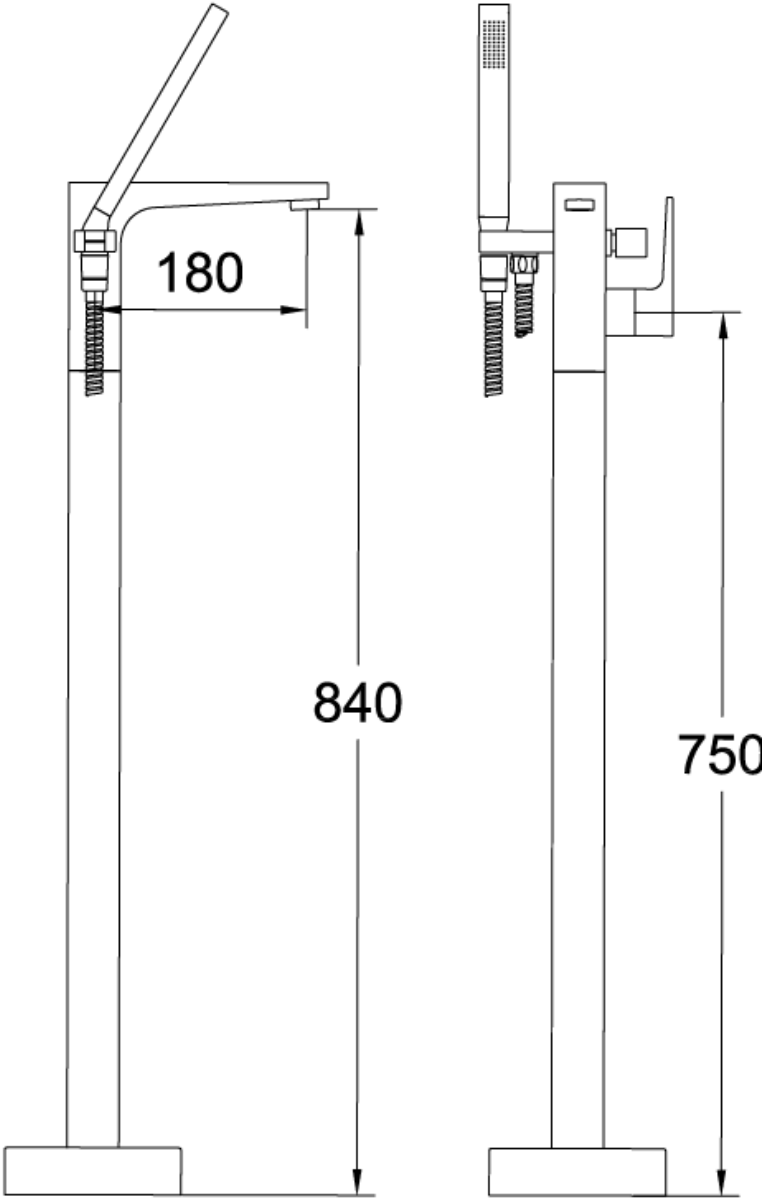

Floor Standing Bath Shower Mixer

## Installation

### 3 Hole Wall Mounted Basin Mixer & Bath Filler

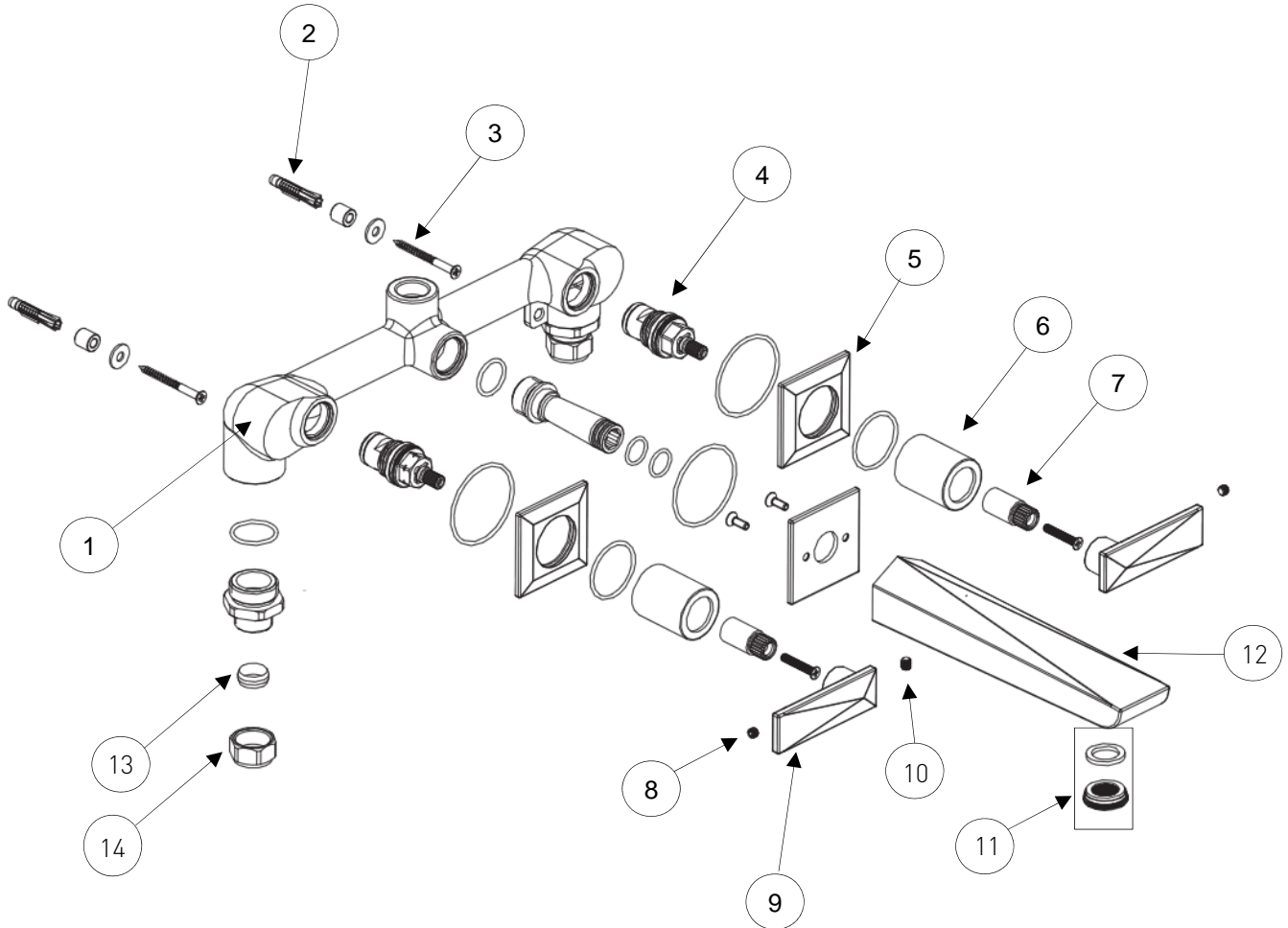

- |                   |    |                       |    |
|-------------------|----|-----------------------|----|
| 1. Body           | x1 | 8. Handle Grub Screw  | x2 |
| 2. Wall Plug      | x2 | 9. Handle             | x2 |
| 3. Screw          | x2 | 10. Spout Grub Screw  | x1 |
| 4. Valve          | x2 | 11. Flow Straightener | x1 |
| 5. Plinth         | x2 | 12. Spout             | x1 |
| 6. Shroud         | x2 | 13. Olive             | x2 |
| 7. Spline Adaptor | x2 | 14. Compression Nut   | x2 |

## Installation cont.

### 3 Hole Wall Mounted Basin Mixer



Prior the drilling into walls, check there no hidden electrical wires, cables or water supply pipes with the aid of an electronic detector.

If you use power tools do not forget to:

- Wear eye protection
- Unplug equipment after use.

1. Identify all components are present prior to starting installation.
2. Decide on the final position of the basin mixer (1).
3. Plumb up the hot and cold supply pipes to the required position.
4. Attach pipework to the hot and cold inlets (hot on the left and cold on the right when viewed from the front) using a ½" BSP to 15mm connection (Not supplied).
5. Secure mixer body using the screws (3) and wall plugs (2).  
**Note:** Before finishing the wall turn on water supplies to check both correct mixer function and for leaking connections.
6. Set fitting into wall and complete wall surface.  
**Note,** it is important that the spout (12) is not damaged and that sufficient thread is left exposed to allow the spout (12) and the valve shrouds (6) to fit.
7. Fit the spout (12) and tighten the grub screws (10) to secure in position.
8. Screw the valve shrouds (6) onto the valves (4) and push the plinth (5) onto the shroud (6). It maybe necessary to use silicon sealant on the plinths to secure them into position.
9. Push the handles (9) onto the valve shrouds (6). Tighten the grub screw (8).
10. Check all joints and connections for leaks.

## Installation cont.

### Floor Standing Bath Shower Mixer

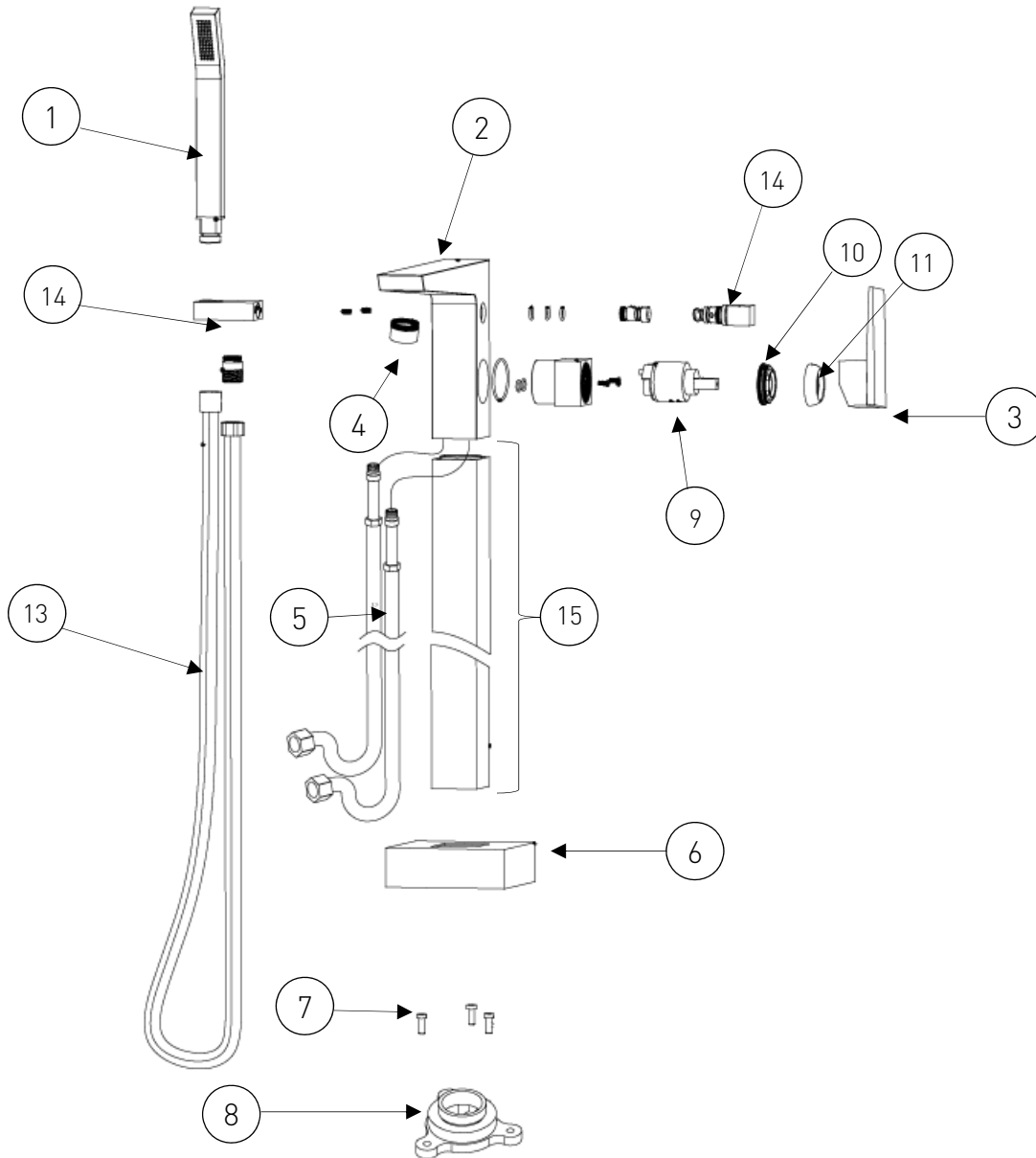

|                 |    |                             |    |
|-----------------|----|-----------------------------|----|
| 1. Handset      | x1 | 9. Cartridge                | x1 |
| 2. Tap Body     | x1 | 10. Cartridge Retaining Nut | x1 |
| 3. Handle       | x1 | 11. Shroud                  | x1 |
| 4. Anti- Splash | x1 | 12. Diverter                | x1 |
| 5. Flexi Tails  | x2 | 13. Shower Hose             | x1 |
| 6. Plinth       | x1 | 14. Handset Holder          | x1 |
| 7. Fixings      | x3 | 15. Extension Body          | x1 |
| 8. Fixing Base  | x1 |                             |    |



## Installation Cont.

### Floor Standing Bath Shower Mixer

1. Identify all components are present prior to installation.  
**Note:** If the bath filler is to be fitted onto wooden floorboards, the boards must be reinforced with additional wooden batons due to the height and weight of the bath filler. If the floorboards are not reinforced this may result in the bath filler flexing slightly during operation.
2. Slide the plinth (7) along the body and screw the fixing base (9) onto the tap body (2) and decide on the required position of the bath filler.
3. Mark the 3 fixing holes of the base onto the floor surface, also marking a central 34 mm hole for the flexi tails.
4. Remove the bath filler and drill suitable holes for the fixings (8) and the central 34 mm hole.
5. Terminate suitable pipework for the water supplies under the floor and ensure the flexi tails (6) will be able to connect once the bath filler is fitted.
6. Connect the flexi tails (6) to the water supplies. The flexi tails are coloured red for hot and blue for cold.
7. Reposition the bath filler in to the chosen position and secure using the fixings (8) supplied.
8. Pull the plinth (7) down to cover the base (9).
9. Operate the mixer in both bath and shower mode. To switch from bath to shower mode, pull and then twist the diverter (13). To revert back to bath fill turn the diverter back.
10. Turn on water supplies. Operate handle (3) and leave for a few minutes, letting the water flow through, to check all joints and connections for leaks, before finishing floor work.

## Maintenance

### General Cleaning

Your fitting has a high quality finish and should be treated with care to preserve the visible surfaces. All finishes will wear if not cleaned correctly. The only safe way to clean your product is to wipe with a soft damp cloth. Stains can be removed using washing up liquid. All bathroom cleaning products (powders and liquids) will damage the surface of your fitting, even the non-scratch cleaners.

**Note:** Never use abrasive detergents or disinfectants or those containing alcohol, hydrochloric acid or phosphoric acid.



Bristan recommend E-cloth for cleaning all of our bathroom & kitchen products. Using just water, E-cloth gives a smear free, deep clean by breaking up and holding dirt, which normal cloths leave behind. Order through your Bristan stockist (order code: E-CLOTH).

We advise that your fitting is regularly serviced in hard water areas to maintain optimum performance.

### Cleaning the Showerhead:

#### EBY FSBSM C

Your Bristan showerhead has rub-clean nozzles for easy cleaning. Simply rub your fingers across the rubber spray jets regularly and before you turn the shower on to remove any scale or debris.

The hardness of the water in your area will determine how often you should clean your showerhead. Build up of scale in particularly hard water areas combined with constant use means you may need to clean your showerhead once a week. To ensure continued performance the showerhead needs to be regularly descaled.

**Tip:** If the showerhead is heavily scaled or has not be maintained for a long period of time a solution of hot water and white vinegar may be needed to clear the scale.

Mix a 50/50 solution and rub the nozzles thoroughly with the solution making sure the solution gets into all of the nozzles.

Wash off the solution with clean water.

## Maintenance cont.

### Cleaning the Valves:

If your fitting begins to leak the follow should be carried out:

Isolate both hot and cold water supplies to the tap by either:

- Turning the water supply off at the mains stopcock or
- Turning off the isolation valves to the tap

1. Unscrew the grub screw at the side of the handle and remove the handle.
2. Remove the plinth(if necessary) and then unscrew the shroud.
3. Unscrew the valve using a suitable spanner.
4. Lift out the valve and clean thoroughly. Be sure to check and clean out the seating within the mixer body.
5. If necessary replace the valve.

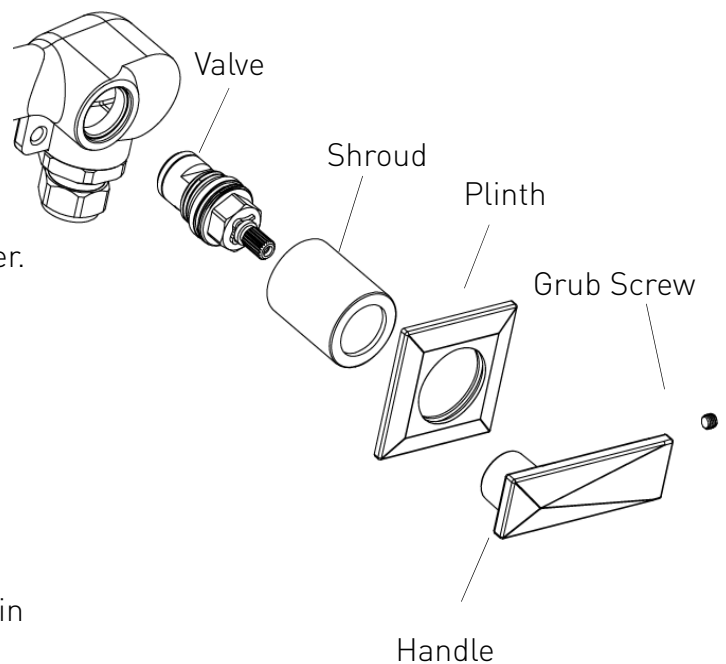

Please visit [www.bristan.com/sparesfinder](http://www.bristan.com/sparesfinder) in order to find spare parts for this product.

6. Place the valve back into the mixer body and tighten the valve fully using a suitable spanner.
7. Screw the shroud back onto the valve then push the plinth (if removed) onto the shroud and replace the handle. Tighten the grub screw.
8. Turn on water supply and check for leaks.
9. Contact our helpline if problem persists.

## Maintenance cont.

### Cleaning the Cartridge:

If your fitting begins to leak the following should be carried out;  
Isolate both hot and cold water supplies to the tap by either:

- Turning the water supply off at the mains stopcock or
  - Turning off the isolation valves to the tap.
1. Remove the handle losing the grub screw.
  2. Unscrew the shroud and cartridge retaining nut and pull the cartridge out from the body.
  3. Clean the cartridge thoroughly under cold water to remove any build up of limescale or debris.

Please visit [www.bristan.com/sparesfinder](http://www.bristan.com/sparesfinder) in order to find spare parts for this product.

4. Replace the cartridge into the body and tighten the retaining nut to secure in place.
5. Screw the shroud onto the retaining nut and push the handle onto the cartridge. Tighten the grub screw.

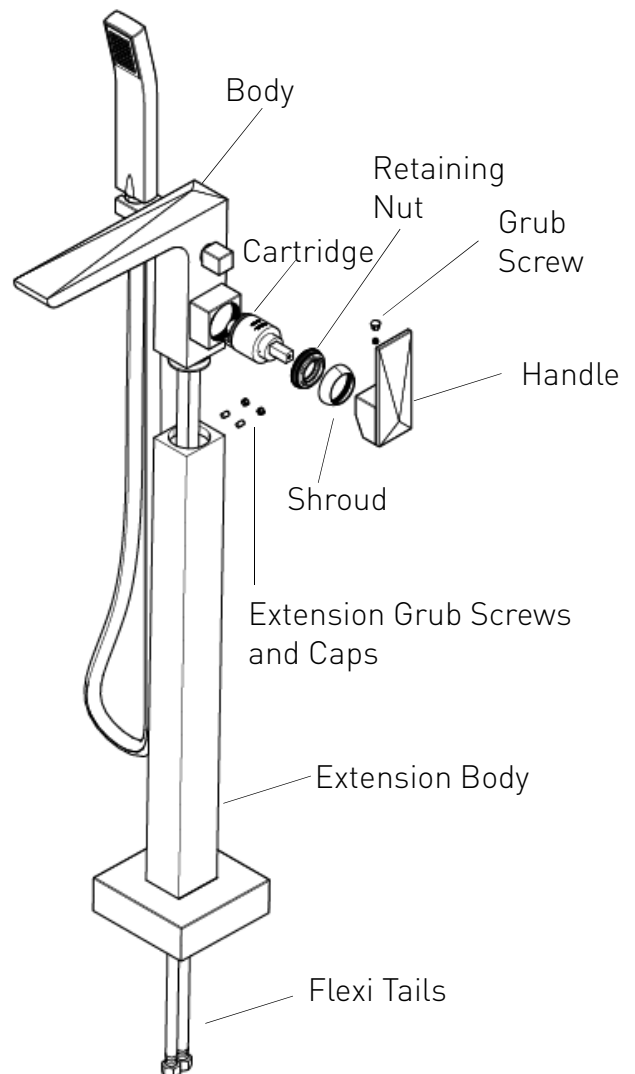

### Removing the Flexi Tails

Should you need to replace the flexi tails, the following should be carried out;

**Note:** Before carrying out any maintenance insure the water supplies are isolated.

1. Remove the bath shower mixer from the floor.
2. Remove the extension caps and grub screws and pull the body up.
3. Unscrew the flexi tails from the bottom of the mixer body.
4. Pull the extension up over the flexi tails and replace with new ones supplied by Bristan.
5. Refit the extension body securing to the floor and screw the flexi tails into the mixer body.
6. Tighten the extension grub screws and fit the caps to secure the mixer body in position.
7. Turn on the water supplies.

## Troubleshooting

| Symptom                                                                     | Cause                                                                                    | Remedy                                                                                       |
|-----------------------------------------------------------------------------|------------------------------------------------------------------------------------------|----------------------------------------------------------------------------------------------|
| No flow or poor flow rate.                                                  | Partially closed stop or service valve in water supply pipework to the tap.              | Open stop or service valve.                                                                  |
|                                                                             | Head of water is below the minimum distance required.                                    | Refer to the Specification section for minimum pressures required.                           |
|                                                                             | Possible airlock / blockage in supply pipework                                           | Remove water supplies from the fitting and flush the system to remove any airlocks / debris. |
|                                                                             | Cartridge / Valve not opening fully.                                                     | Service fitting. Refer to maintenance section on pages 11-12.                                |
| Water dripping for a few seconds after the tap has been turned off.         | This is caused by 'capillary action' and residual water in the spout being siphoned out. | This should only last for a couple of seconds, and is normal after use.                      |
| Constant dripping / leaking when the tap is not in use.                     | Cartridge / valve not fully shutting off.                                                | Service fitting and replace cartridge/ valve. Refer to maintenance section on page 11-12     |
| Fitting does not turn on.                                                   | Water supplies not turned on.                                                            | Check that the water supplies to the fitting are turned on.                                  |
|                                                                             | Closed stop or service valve.                                                            | Open stop or service valve.                                                                  |
| Water does not come out of the showerhead when using the bath shower mixer. | Diverter mechanism not fully open.                                                       | Pull the diverter out fully and twist to lock into position.                                 |
|                                                                             | Insufficient water pressure / header height.                                             | Refer to the specification section for minimum pressures required.                           |

## Bristan Guarantee

At Bristan, we want to make things as easy as possible for our customers. That's why we design products that are easy to fit and use, and that are quality tested to make sure they won't let you down. It's also why we offer solid guarantees on all products, effective from the date of purchase, to give you peace of mind.

All Bristan taps are covered by a **5 year guarantee**. This also includes **2 years labour cover** which means that, in the unlikely event that there is a problem in the first 2 years after purchase, we'll send one of our expert engineers to fix it.

\*Labour is provided by an approved Bristan Care engineer or appointed representative. The guarantee only applies to products with a manufacturing fault. There will be a call out charge for any incidents where no fault has been found with the product, or if the issue is due to poor installation or maintenance.

### Guarantee Terms and Conditions

This guarantee is in addition to your statutory and other legal rights and is subject to the following conditions:

- The product was purchased within the United Kingdom or Republic of Ireland.
- The guarantee applies solely to the original purchaser with proof of purchase.
- The installation must allow ready access to all products for the purpose of inspection, maintenance or replacement.

- Repair under this guarantee does not extend the original expiry date. The guarantee on any replacement parts or product ends at the original expiry date.
- Any part found to be defective during the guarantee period will be replaced without charge, providing that the product has been installed in accordance with the instructions given in this guide and used as the manufacturer intended.
- The guarantee does not cover:
  - Damage or defects caused by:
    - general wear and tear (including special non-chrome finishes; components such as filters, seals, 'O' rings and washers)
    - incorrect installation
    - repair using non-Bristan parts
    - accidental or wilful misuse
    - corrosion and the use of inappropriate cleaning products.
    - system debris including the build up of limescale (which can be controlled through regular servicing and maintenance).
- Compensation for loss of use of the product or consequential loss of any kind.

In the interests of continuous product improvement, Bristan reserves the right to alter product specifications without notice.

The Bristan Product Guarantee does not affect your statutory rights as a consumer.

## •Need help?

If this product does not function correctly when first used, contact **Bristan Care Customer Service on 0844 701 6273** where our expert team of advisors will be able to offer you help and advice.

## •Problems during the guarantee period

In the unlikely event that you encounter any problems with the product during the guarantee period, contact **Bristan Care Customer Service on 0844 701 6273** with your proof of purchase and we will work to resolve the problem quickly.

## Bristan Care Customer Support

Bristan customers also benefit from the support of Bristan Care, our comprehensive customer support package which offers:

### Technical support hotline

(Tel: **0844 701 6273**) with access to fully trained advisors who can offer installation advice, talk you through quick maintenance checks, or recommend the best course of action to fix any problems with a product

### Expert advice

Find easy to follow 'how to' video guides and technical FAQs online at [www.bristan.com](http://www.bristan.com). Our guides take you step-by-step through many product installations and you can find plenty of easy guides to quick product fixes and servicing.

## Spare parts

We hold thousands of spares and we keep them for discontinued products for over seven years. Spares can easily be ordered online at [www.bristan.com](http://www.bristan.com) and are dispatched the same day.

## Expert plumbing engineers

If we can't solve the problem over the 'phone or with a spare part, then we'll send out one of our Bristan Care engineers to take a look. Bristan Care engineers provide free support for products that are within guarantee, but are also available to service products that are out of guarantee for a small charge. For details, please call customer services on **0844 701 6273**.

# BRISTAN

This booklet covers product codes

EBY 3HWMBAS C

EBY 3HWMBF C

EBY FSBSM C

**Helpline**

**0844 701 6273**

Bristan Group Limited

Birch Coppice Business Park, Dordon, Tamworth, Staffordshire B78 1SG

A Masco Company

Website: [www.bristan.com](http://www.bristan.com)

Telephone: 0844 7016 274      Facsimile: 0844 701 6275

Email: [enquire@bristan.com](mailto:enquire@bristan.com)

FI (EBONYEXTENSIONTAPRANGE) – REV. D1