

BRISTAN

Installation Instructions and User Guide

Thermostatic Recessed Dual Control Shower Valve

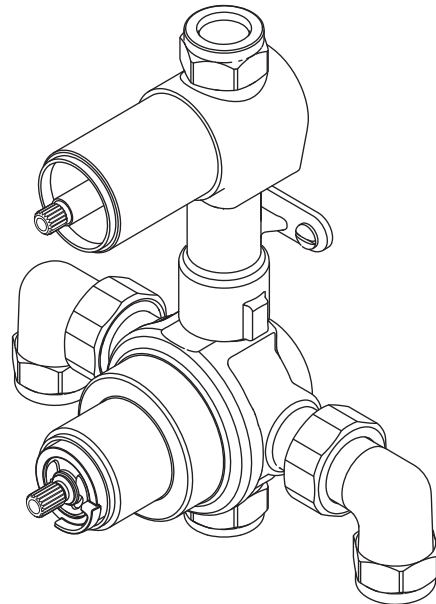

Models covered: CAS SHCVO C,
COB SHCVO C, ORB SHCVO C,
PIV SHCVO C, SAI SHCVO C &
TRI SHCVO C.

Please keep this booklet for future
reference.

Installer, when you have read these
instructions please ensure you leave
them with the user.

Contents

Thank you for choosing Bristan, the UK's leading showers and taps expert. We have designed this product with your enjoyment in mind. To ensure that it works to its full potential, it needs to be fitted correctly. These fitting instructions have been created to give you all of the information you need and, if you need any further help, please do not hesitate to give us a call on 0844 701 6273.

Important Safety Information	3
General Information	4
Product Features	5
Specifications	6
Pack Contents	7-12
Prior to Installation	13
Installation	14-16
Shower Valve	14-15
Wall Outlet	16
Operating the Shower	17
Maintenance	18
Adjusting the Temperature	19
Troubleshooting	20-21
Guarantee	22-23

Important Safety Information

- Please read these instructions thoroughly and retain for future use.
- All products manufactured and supplied by Bristan are safe provided they are installed, used correctly and receive regular maintenance in accordance with these instructions.

If you are in any doubt about your ability to install this product safely you must employ the services of an experienced qualified plumber.

- These fittings need to be installed in accordance with, and meet the requirements of the Water Supply (Water Fittings) Regulations 1999 and Scottish Byelaws 2004.
- Remove all packaging and check there are no missing or damaged parts.
- Before starting any installation please consider the following:
 - Before drilling into walls, check that there are no hidden electrical wires, cables or water supply pipes. This can be checked with the aid of an electronic detector.
- If power tools are used do not forget to:
 - Wear eye protection
 - Unplug equipment after use

⚠ Warning: Before installing the new shower valve it is essential that you thoroughly flush through the pipework in order to remove any remaining swarf, solder, etc. Failure to carry out this procedure could cause problems or damage to the workings of the shower valve.

- Fitting isolation valves to the inlet feeds is required for ease of maintenance.
- Access **must** be made available to the shower valve / mixer body for maintenance / servicing purposes.

⚠ Warning: Do not operate this product if you suspect it is frozen. Do not site the Mixing Valve where it might be subjected to freezing conditions.

- These shower valves **must** not be modified in any way as this will invalidate the guarantee.

General Information

This product has been tested to the Water Regulations Advisory Scheme (WRAS) and satisfies the requirements of the Water Supply (Water Fittings) Regulations 1999 and current bylaws.

For full Installation Requirements & Notes (IRN) please visit www.wras.co.uk/directory.

BS7600 recommends the temperature of stored water should never exceed 65°C. A stored water temperature of 60°C is considered sufficient to meet all normal requirements and will minimise the build up of lime scale in hard water areas.

If the shower valve is installed at low pressure (tank fed), then the minimum distance from the highest installed position of the showerhead to the underside of the cold tank should be at least 1 metre to ensure adequate performance.

Note: Nominally equal (balanced) inlet supply pressures are recommended for optimum performance.

This shower valve should be installed in compliance with the Water Supply (Water Fittings) Regulations 1999 and the Scottish Bylaws 2004.

If in doubt, contact a registered plumber or your Local Water Authority or the Secretary of The Institute of Plumbing, address as follows;-

The Institute of Plumbing,
64 Station Lane,
Hornchurch,
Essex,
RM12 6NB
Tel: 01708 472791

Recommended Usage			
Domestic	✓	Heavy Commercial	✗
Light Commercial	✓	Health Care	✗

Product Features

1. On / off control

Turn the handle anti-clockwise to turn on and increase the flow of water.

Turn the handle clockwise to turn off the flow of water.

2. Temperature control

Adjustable temperature control.

Turn the handle clockwise for a cooler temperature.

Turn the handle anti-clockwise for a hotter temperature.

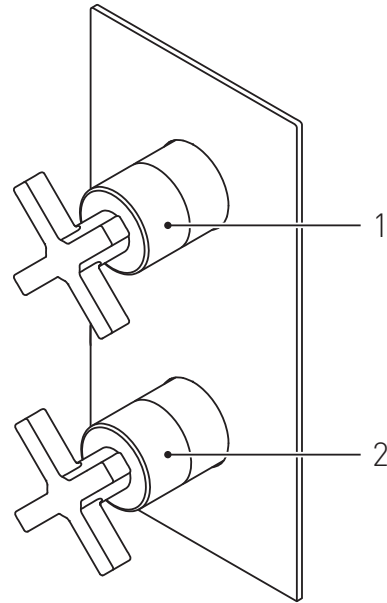

CAS SHCVO C shown

Specifications

Inlet connections: 15mm compression with 150mm between centres.

Minimum working pressure: 0.2 bar

Note: This shower has been designed to deliver a high flow of water on low pressure systems, however depending on the installation, type of system and shower accessories used, a higher pressure maybe required to optimise the showering experience.

Maximum working pressure: 5 bar

Maximum static pressure: 10.0 bar

Note: Static pressure is the build up of pressure when the valve is closed.

Supply requirements:

Minimum cold water supply temperature: 5°C.

Maximum cold water supply temperature: 25°C.

Maximum hot water supply temperature: 80°C.

Note: The inlet hot water temperature must be at least 10°C above the required blend temperature (e.g. shower temperature 43°C: minimum hot water temperature 53°C).

System requirements:

Gravity fed hot & cold (Equal pressures)

Gravity fed hot & mains cold (Differential pressure, maximum ration 5:1)

Unvented systems

Instantaneous water heater (Combination boiler)

Pumped system

Note: When using a pumped system we recommend that an essex flange is used.

Important: Minimum wall cavity depth: 35mm

For full dimensional drawings please visit www.bristan.com

Min - Max Concealing plate thickness	
45-75mm	58-75mm
PIV SHCVO C	CAS SHCVO C
	COB SHCVO C
	ORB SHCVO C
	SAI SHCVO C
	TRI SHCVO C

Pack Contents - CAS SHCV0 C

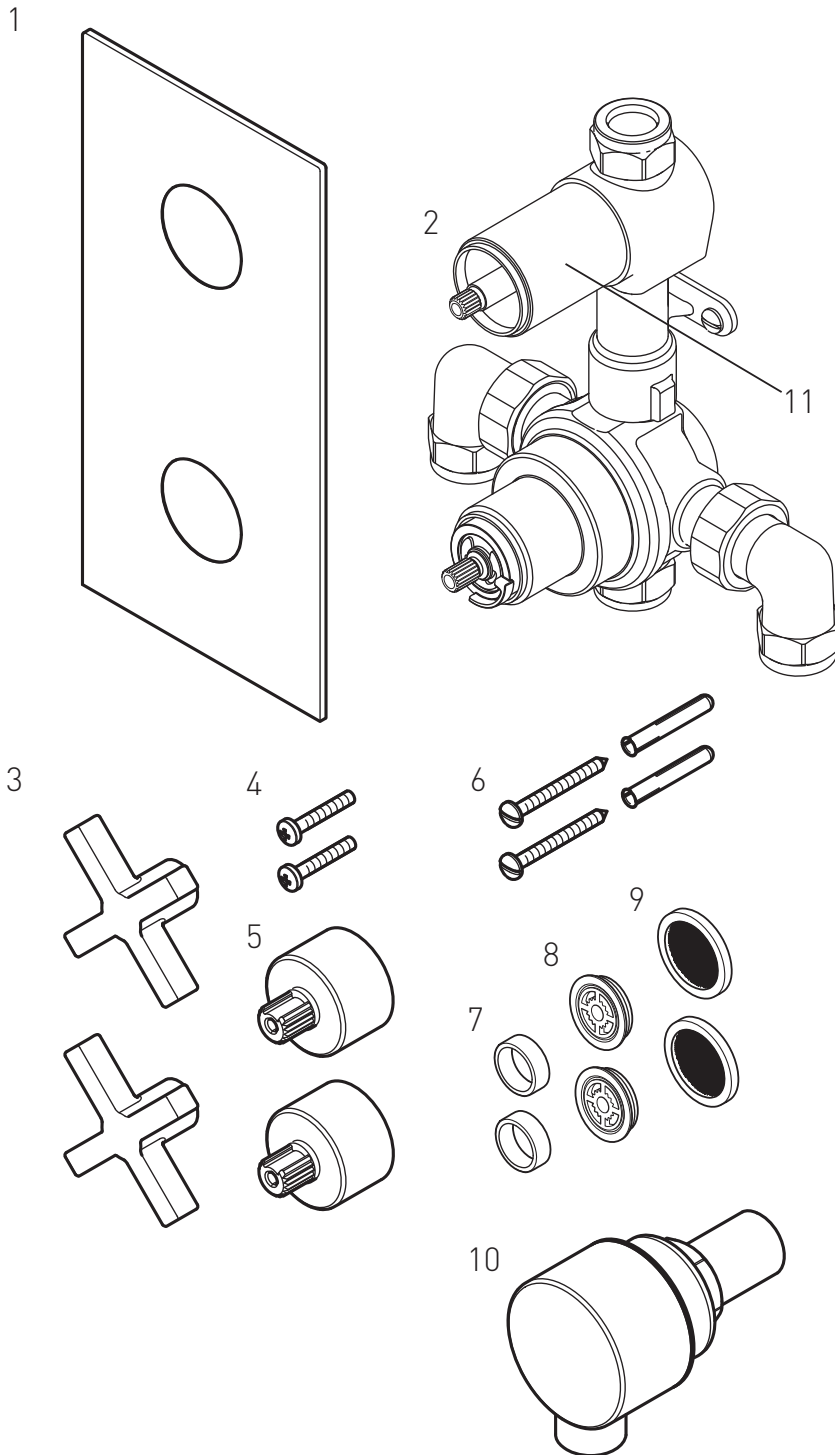

1. Concealing plate x1
2. Valve body x1
3. Handles x2
4. Shroud extension screws x2
5. Shroud extensions x2
6. Valve body fixings x2/2
7. Inserts x2
8. Flow regulators x2
9. Filter washers x2
10. Wall outlet x1
11. Shrouds x2

Need help? Give us a call on 0844 701 6273 and speak to one of our trained advisers.

7

Pack Contents - COB SHCVO C

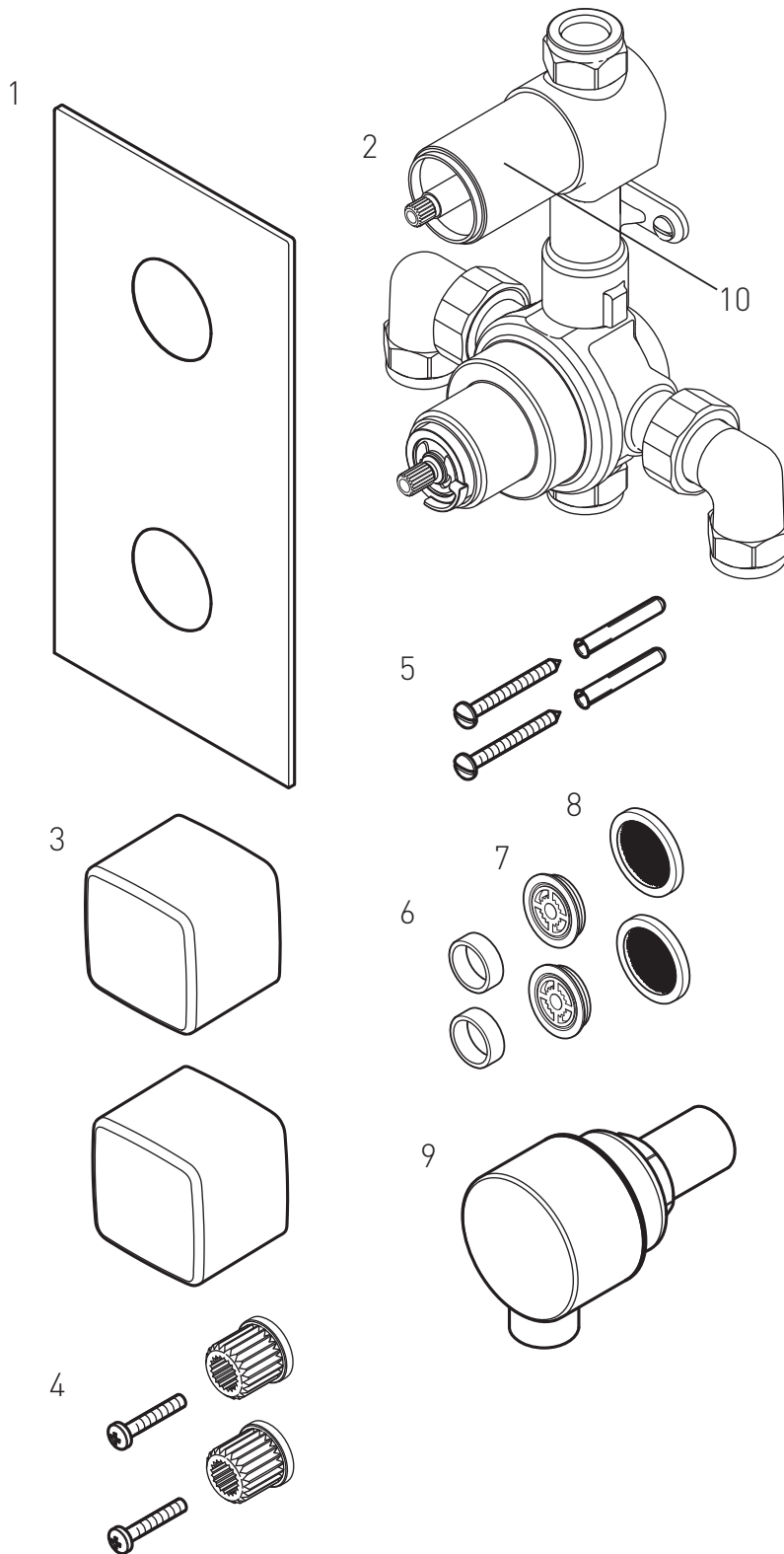

- 1. Concealing plate x1
- 2. Valve body x1
- 3. Handles x2
- 4. Spline adaptors x2
- 5. Valve body fixings x2/2
- 6. Inserts x2
- 7. Flow regulators x2
- 8. Filter washers x2
- 9. Wall outlet x1
- 10. Shrouds x2

Pack Contents - ORB SHCVO C

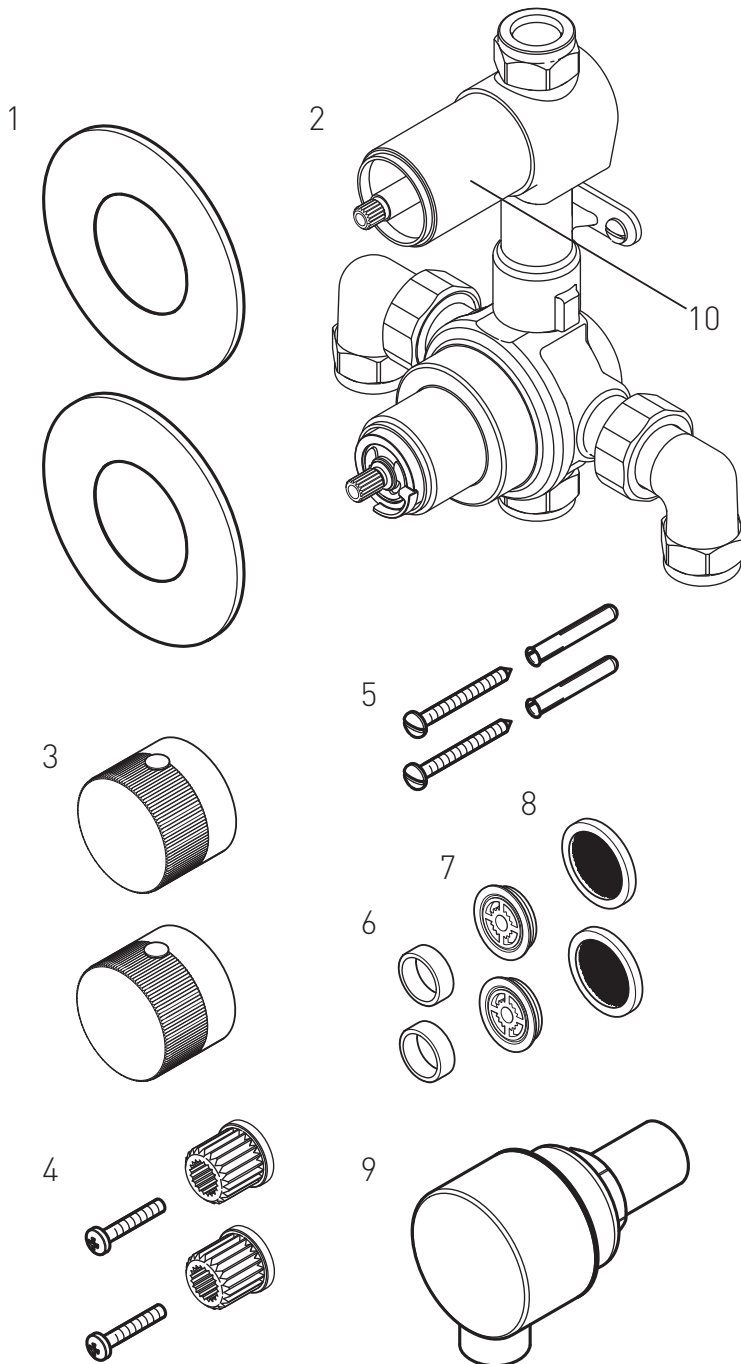

1. Concealing plate x2
2. Valve body x1
3. Handles x2
4. Spline adaptors x2
5. Valve body fixings x2/2
6. Inserts x2
7. Flow regulators x2
8. Filter washers x2
9. Wall outlet x1
10. Shrouds x2

Pack Contents - PIV SHCVO C

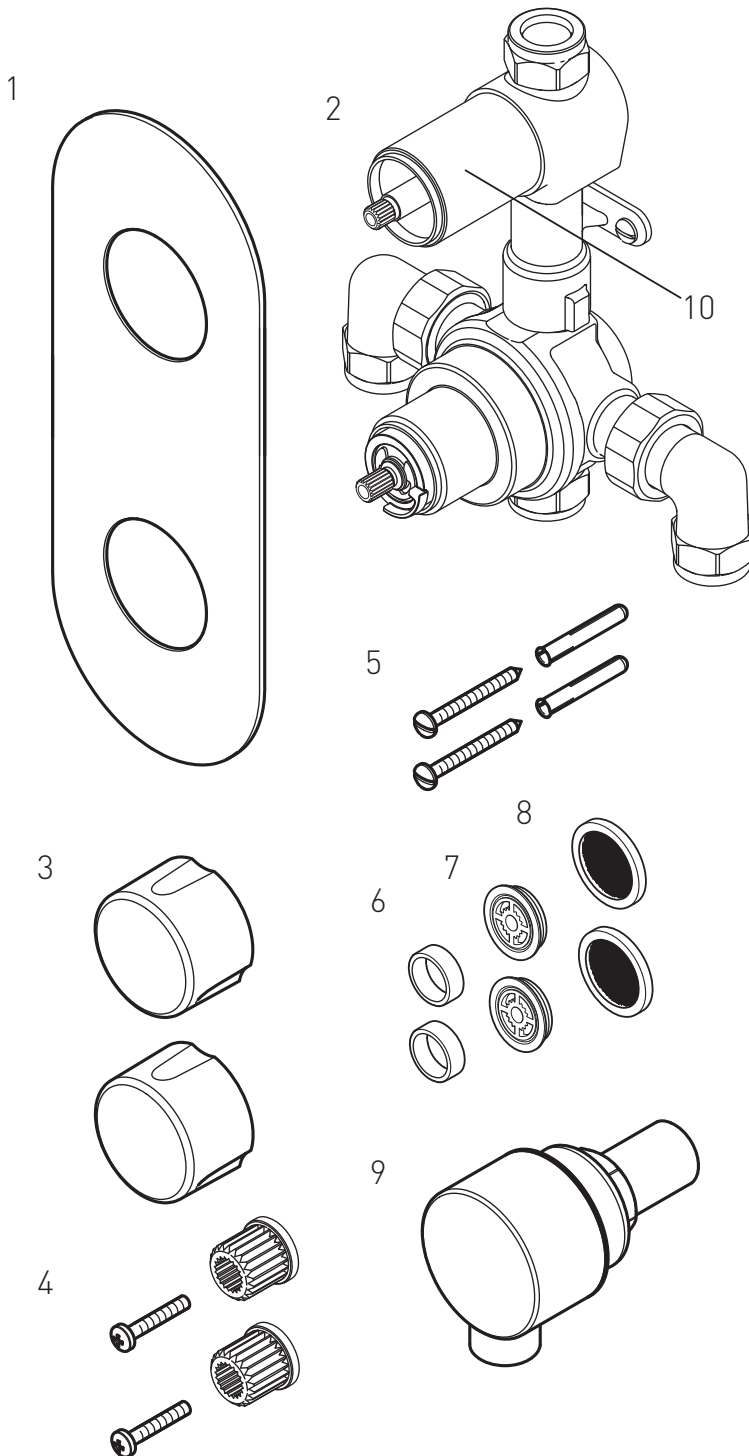

1. Concealing plate x1
2. Valve body x1
3. Handles x2
4. Spline adaptors x2
5. Valve body fixings x2/2
6. Inserts x2
7. Flow regulators x2
8. Filter washers x2
9. Wall outlet x1
10. Shrouds x2

Pack Contents - SAI SHCV0 C

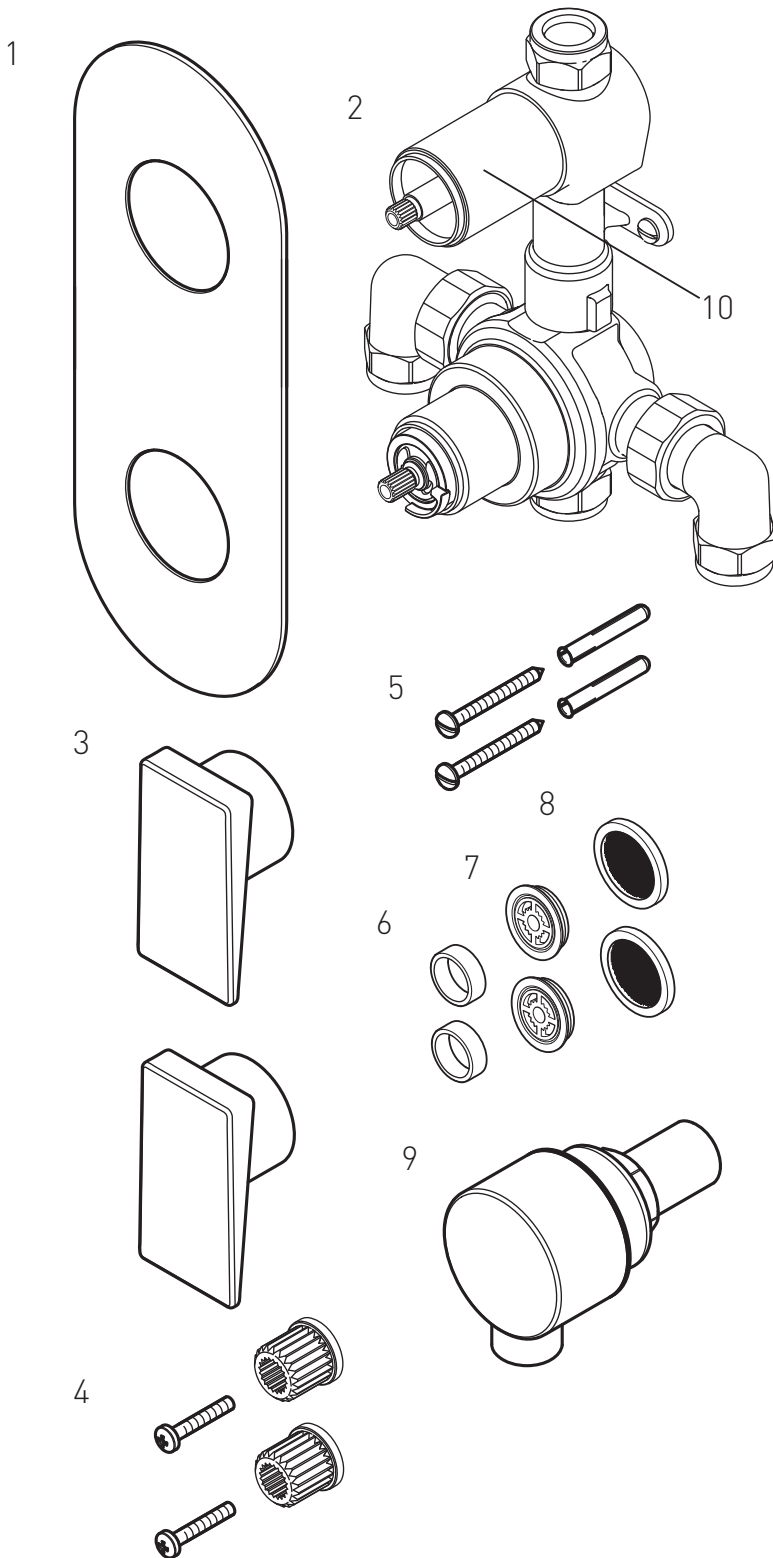

1. Concealing plate x1
2. Valve body x1
3. Handles x2
4. Spline adaptors x2
5. Valve body fixings x2/2
6. Inserts x2
7. Flow regulators x2
8. Filter washers x2
9. Wall outlet x1
10. Shrouds x2

Need help? Give us a call on 0844 701 6273 and speak to one of our trained advisers.

11

Pack Contents - TRI SHCVO C

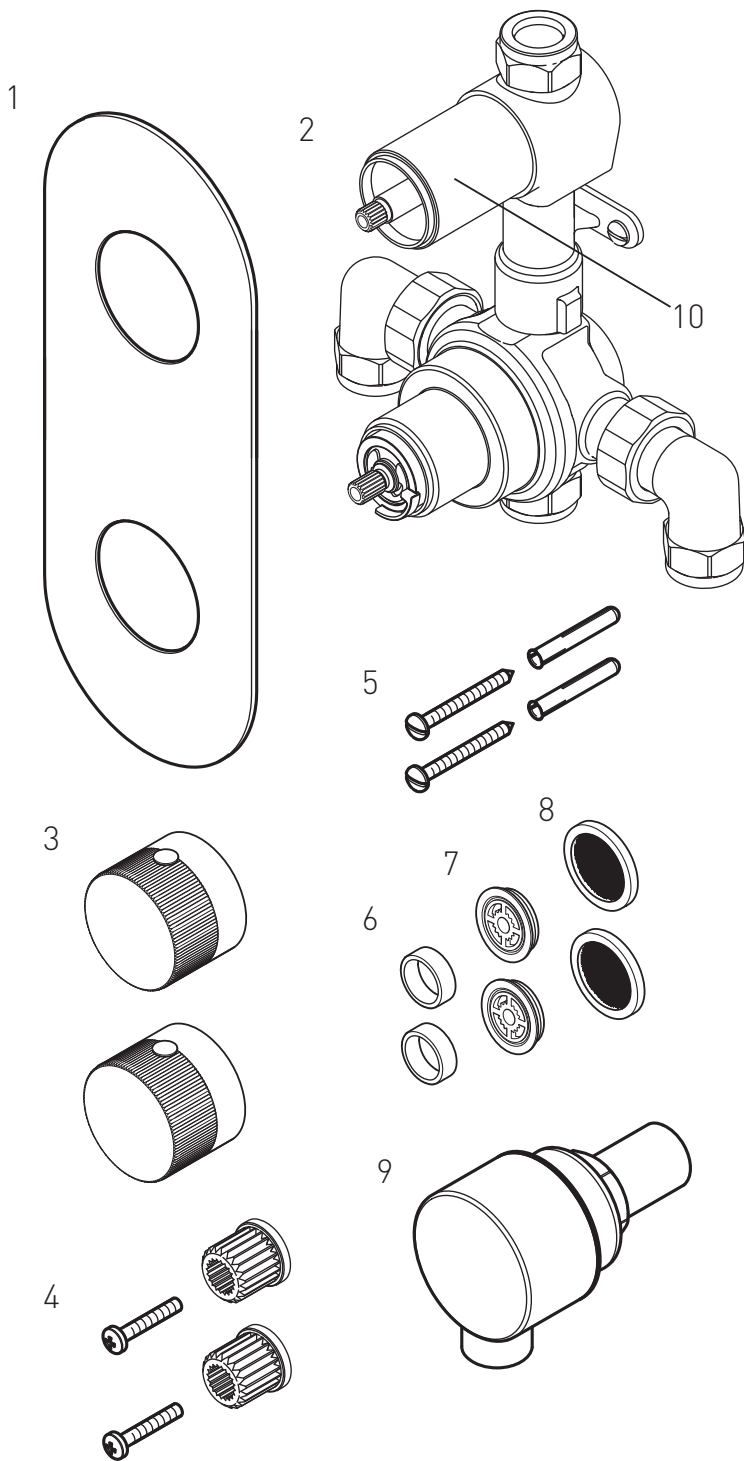

1. Concealing plate x1
2. Valve body x1
3. Handles x2
4. Spline adaptors x2
5. Valve body fixings x2/2
6. Inserts x2
7. Flow regulators x2
8. Filter washers x2
9. Wall outlet x1
10. Shrouds x2

Prior to Installation

Flow Regulators

This shower valve is supplied with a 5 and 7 litre per minute flow regulator loose in the box which must be fitted if the shower valve is installed in conjunction with an instantaneous water heater / combination boiler.

With both flow regulators fitted and by turning the water heater / combination boiler to its hottest setting, will ensure a sufficiently hot water supply to the shower valve during winter months (in the UK), when the mains cold water supply is at its coldest.

To fit the flow regulators

Remove the inlet elbows ensuring the filter washer is also removed. Carefully remove the plastic inserts from the valve inlets and push in the flow regulators. The 7 litre per minute green flow regulator **must** be fitted to the cold inlet and the 5 litre per minute yellow flow regulator **must** be fitted to the hot inlet.

Place the filter washers back into the elbow nuts and tighten the nuts fully onto the outlets.

In the event that this shower valve is not installed with an instantaneous water heater / combination boiler, the flow regulators do not need to be fitted.

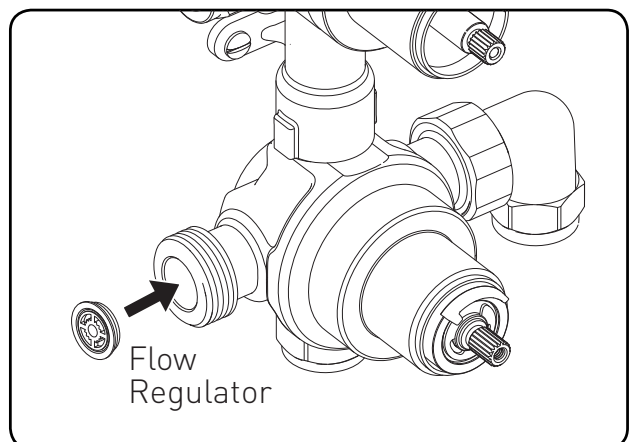
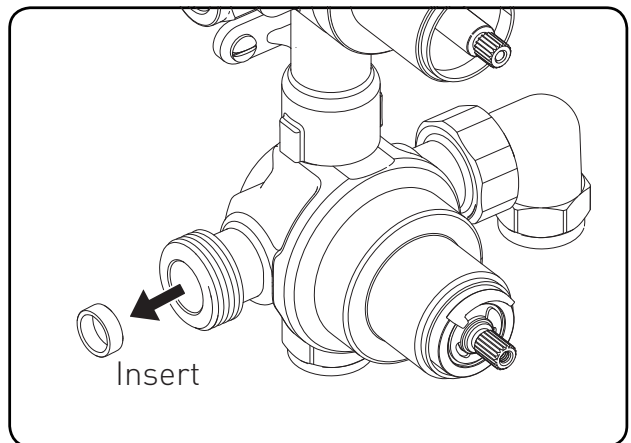
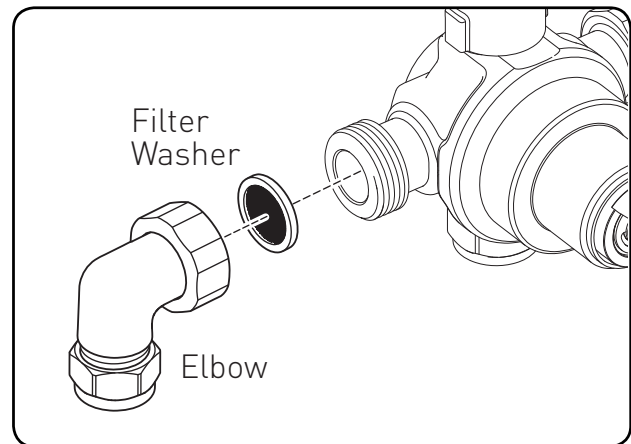

Installation - Shower Valve

This shower valve is designed for new installations where there is no shower valve already installed. Once the shower valve is secured in the wall cavity the wall should be finished and tiled.

Access is required from the rear for future servicing of the shower valve filters. The cartridge can be accessed from the front.

Before Installation

Flush through the pipework to ensure removal of any debris. Turn off the mains water supply and close any isolating valves.

1. Install shower valve

Install suitable battons (if required) onto the rear cavity wall. Place the shower valve in the required position and mark the fixing holes.

Drill suitable holes and insert the wall plugs (if necessary). Securely attach the shower valve to the wall / battons using the screws supplied.

2. Connect water supply pipes

Insert 15mm hot and cold water supply pipes into the inlet connections and tighten nuts, ensuring the olives are fitted.

3. Plumb in outlets

Insert 15mm pipework into the top outlet and plumb into the users chosen products. Ensure the olives are fitted when tightening the nuts.

Important: The ORB SHCVO C can be installed either portrate or landscape.

If the valve is installed landscape the hot water inlet **must** be at the bottom with the cold water inlet at the top.

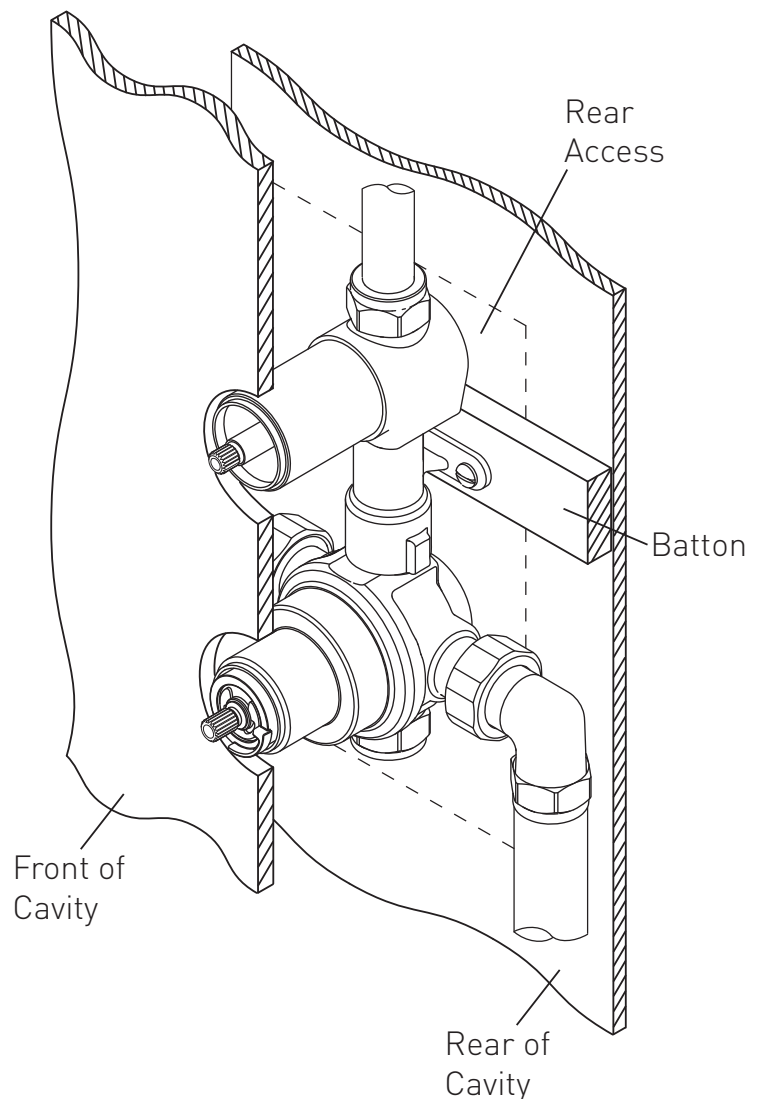

Installation - Shower Valve

4. Finish wall surface

Plasterboard and tile the cavity wall ensuring there is a gap between the tiles and the shower valve

5. Fit concealing plate and handles

Run a bead of waterproof silicon sealant around the inner edge of the concealing plate.

Slide the concealing plate onto the shower valve and apply firm pressure to ensure to silicon sealant spreads.

6. Fit handles

Push the spline adaptors onto the valve spindles.

Push the handles onto the spline adaptors and secure by tightening the grub screw and push-fit the cap into position.

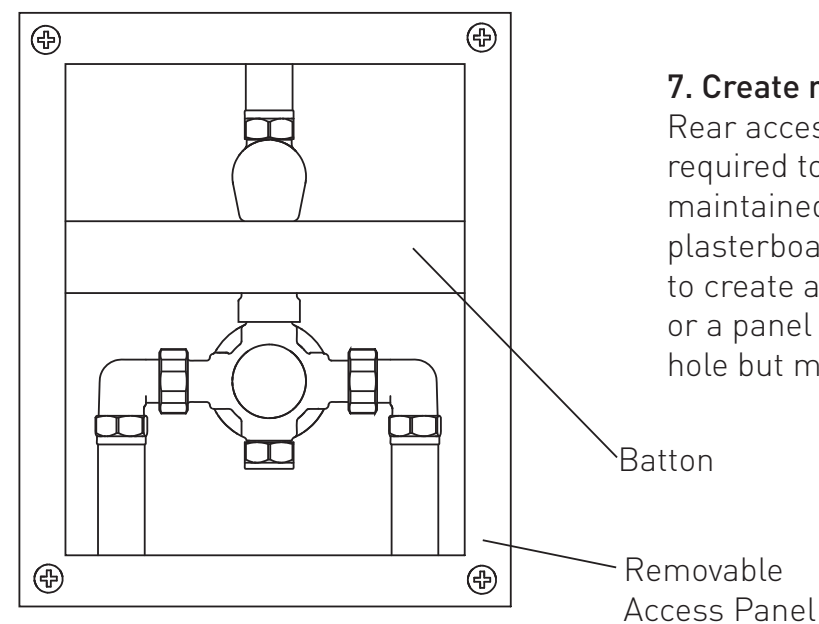
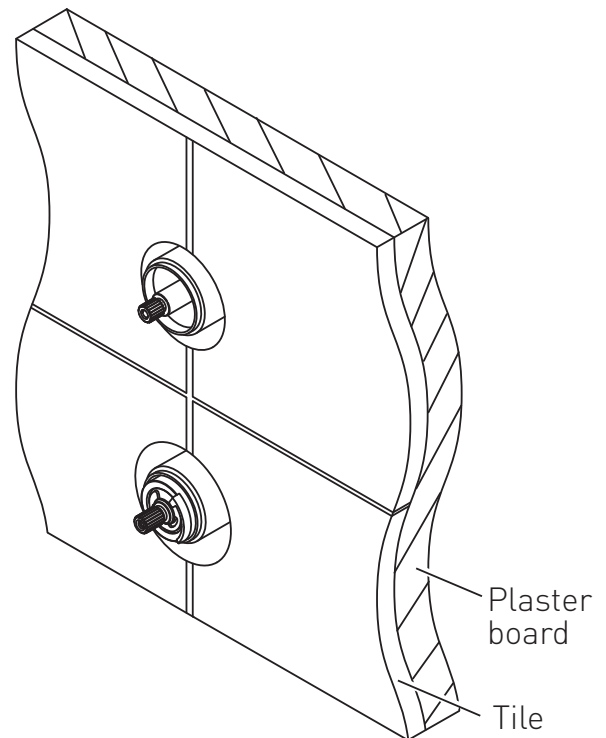

7. Create rear access

Rear access to the shower valve is required to enable the shower to be maintained and serviced. Cut out the rear plasterboard in the back of the wall cavity to create access. A piece of plasterboard or a panel maybe used to cover the access hole but must be removable.

Installation - Wall Outlet

Fitting the Wall Outlet

There are two methods of fixing the wall outlet depending on the type of wall:

a: With rear access once wall finished

Fit the rubber washer to the back of the wall outlet, place the assembly through a 25-30mm hole in the wall and secure with the backnut ensuring the washer is fitted between the backnut and the wall.

Connect the wall outlet assembly to the shower valve outlet.

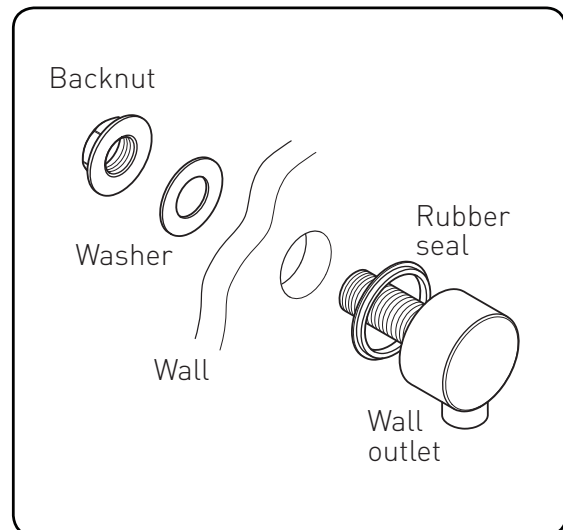

b: Without rear access once wall finished

Fit a '1/2" female connection' (not supplied) within the wall cavity and plumb in from the shower valve. Screw the wall outlet into the '1/2" female connection' using a suitable thread sealant ensuring the rubber seal is fitted to the back of the wall outlet.

Note: The backnut and washer are not required.

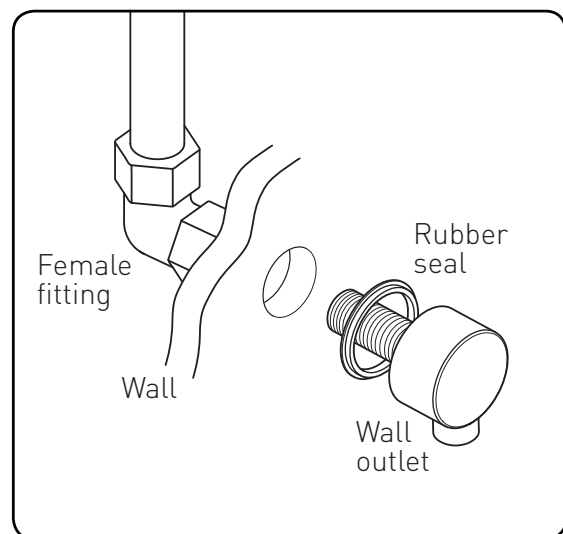

Operating the Shower

1. On / off control

Turn the handle anti-clockwise to turn on and increase the flow of water.

Turn the handle clockwise to turn off the flow of water.

2. Temperature control

Adjustable temperature control.

Turn the handle clockwise for a cooler temperature.

Turn the handle anti-clockwise for a hotter temperature.

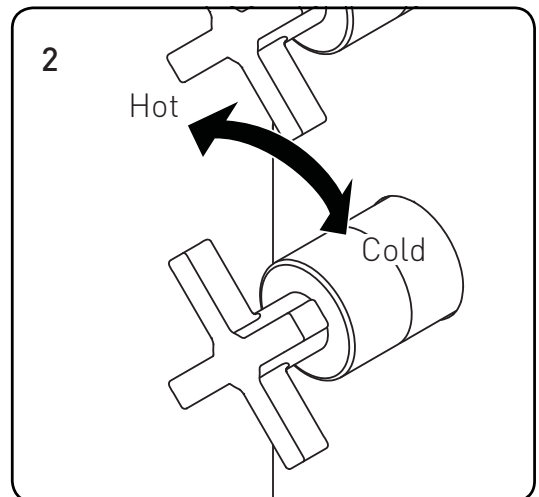
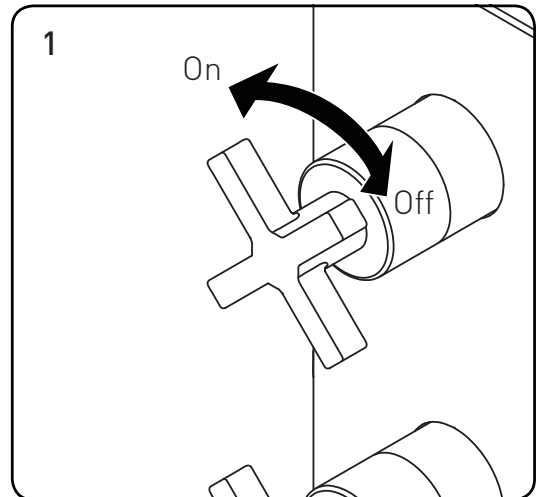

Maintenance

General Cleaning

Your fitting has a high quality finish and should be treated with care to preserve the visible surfaces. All surfaces will wear if not cleaned correctly, the only safe way to clean your product is to wipe with a soft damp cloth. Stains can be removed using washing up liquid. All bath cleaning powders and liquids will damage the surface of your fitting, even the non-scratch cleaners.

Note: Never use abrasive detergents or disinfectants or those containing alcohol, hydrochloric acid or phosphoric acid.



Bristan recommend E-cloth for cleaning all of our bathroom & kitchen products. Using just water, E-cloth gives a smear free, deep clean by breaking up and holding dirt, which normal cloths leave behind. Order through your Bristan stockist (order code: ECLOTH).

free, deep clean by breaking up and holding dirt, which normal cloths leave behind. Order through your Bristan stockist (order code: ECLOTH).

Cartridge Maintenance

We advise that the shower valve is regularly serviced in hard water areas to maintain the flow of water.

Isolate both hot and cold water supplies to the shower valve by either:

- Turning the water supply off at the mains stopcock or
- Turning off the isolation valves to the shower valve.

1. Remove the temperature handle and plastic stop.

⚠ Important: Take note of the position of the plastic stop and handle - They must be refitted in the same position.

2. Unscrew the cartridge anti-clockwise and remove from the valve body.

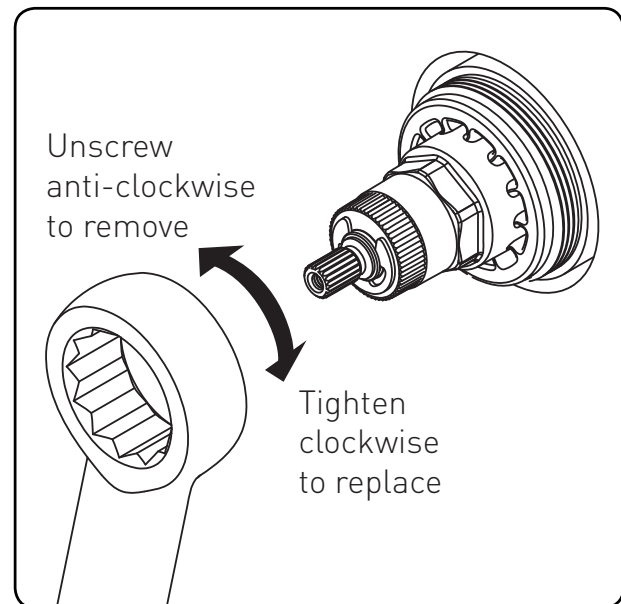

3. Remove the piston and thermostat assembly and place into a bowl. Carefully add hot water (just off the boil) and vinegar to de-scale. Leave in the solution until the water has cooled and rinse with clean water.

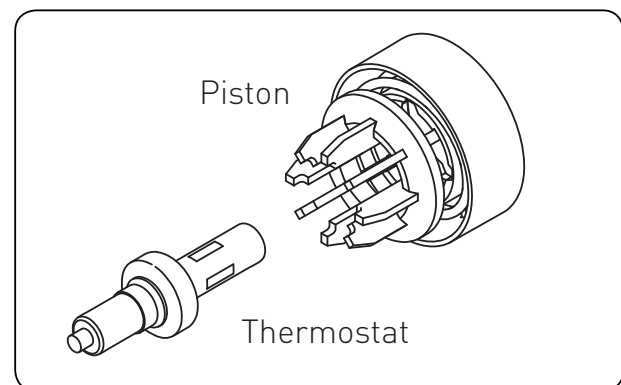

4. Grease the seals with a silicon grease supplied by Bristan (part number: SP-495-0002) and carefully refit.

5. Refit the temperature stop and handle. Reset the maximum temperature.

Adjusting the Temperature

Adjusting the Temperature

The shower valve has been factory set to 42°C with equal (balanced) hot and cold water supply pressures, with the hot water supply at 65°C.

If your operating conditions are different from those above, the outlet water temperature may differ from the factory setting.

If required the shower valve can be re-calibrated to suit your own temperature requirements.

Set the temperature control to the maximum setting and check the

temperature of the water with a thermometer. If the temperature is not correct, re-calibrate the shower valve:

1. Remove the temperature handle but **do not** remove the plastic temperature stop.
2. Turn the spline clockwise to decrease the temperature and anti-clockwise to increase the temperature. Check the temperature and adjust until you achieve the required temperature.
3. Replace the temperature handle ensuring it is fitted back into the maximum position.

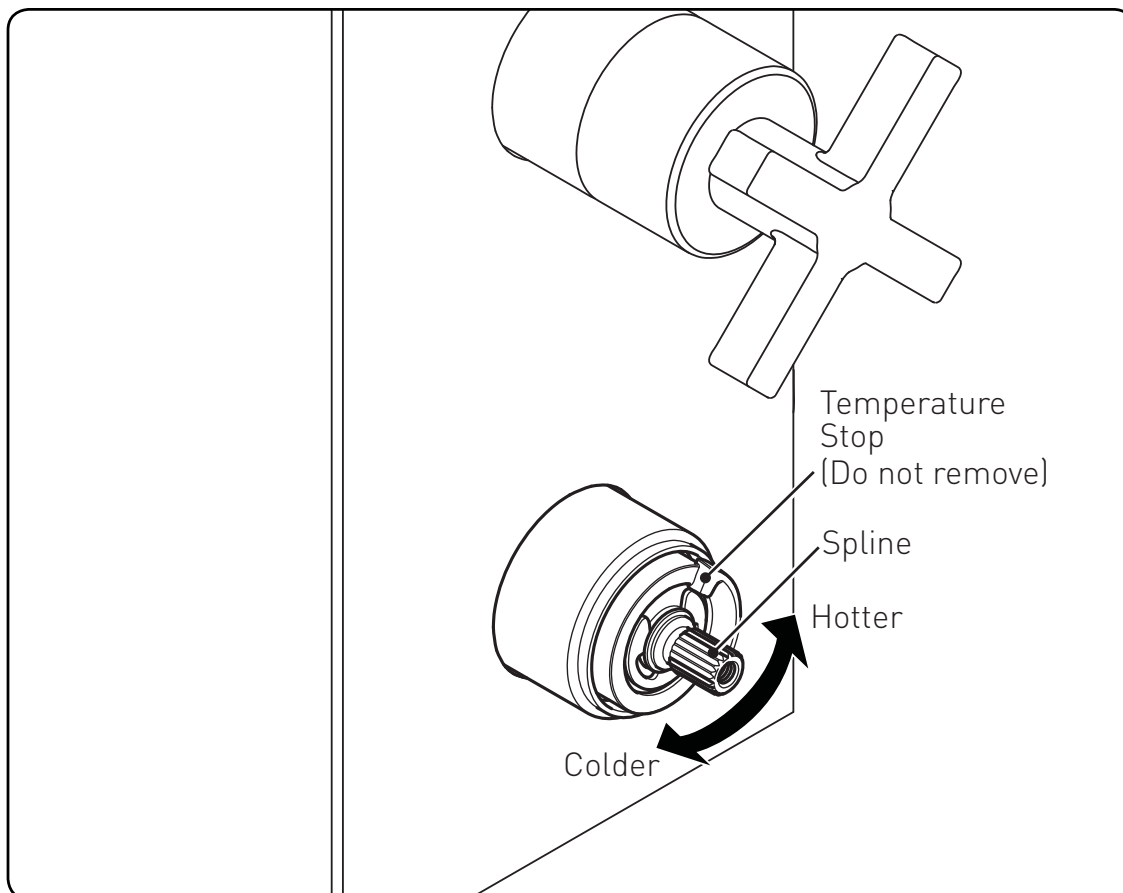

Troubleshooting

Symptom	Cause	Remedy
No flow or low flow rate and / or varying temperatures.	Check showerhead, hose and filters for any blockage.	Clean as necessary, refer to Maintenance section (page 18).
	Partially closed stop or service valve in water supply pipework to the shower valve.	Open stop or service valve.
	Instantaneous water heater cycles on and off as the flow rate or pressure is too low.	Increase water flow rate or pressure through system. Contact the boiler manufacturer.
	Head of water is below the minimum distance required.	Raise the cistern or fit a shower booster pump.
	Inlet filter is partially blocked.	Clean or replace, flush through pipework before refitting.
	Hot or cold water being drawn off elsewhere causing pressure changes or instantaneous boiler temperature changes.	Do not use other water outlets when using the shower.
	Make sure the maintained inlet pressures are nominally balanced and sufficient.	Refer to Specification (page 6).
	Airlock or partial blockage of the pipework.	Flush through pipework to ensure removal of debris and any airlocks.
	No hot or cold water reaching the shower valve.	Check hot and cold feeds (the valve will shut down if either the hot or cold supply fails).
Only hot or cold water from the shower valve outlet.	Partially closed stop or service valve in water supply pipework to the shower valve.	Open stop or service valve.
	Inlet filter is partially blocked.	Clean or replace, flush through pipework before refitting.
	Inlet water supplies are reversed (hot to cold supply).	Check the connections are the correct way round. Hot on the left and cold on the right when viewed from the front. Rework pipework as necessary.

Troubleshooting

Symptom	Cause	Remedy
Maximum water temperature too hot or cold.	Maximum water temperature set incorrectly.	Reset maximum water temperature. Refer to 'Maximum Temperature setting' in Maintenance section (page 18) and 'Adjusting the Temperature' (page 19)
Outlet water temperature too hot / cold.	Inlet filter is partially blocked.	Check inlet filters for any blockages and clean as necessary.
	Installation conditions outside operating parameters.	Refer to Specification (page 6). Service shower valve as recommended. Refer to Maintenance section (page 18). Refer to 'Adjusting the Temperature' section (page 19).
Water temperature too cold - Maximum water temperature incorrectly set.	Hot water temperature is less than 10°C above the required blend temperature.	Adjust hot water temperature or wait for water to reheat if stored system is used.
	Instantaneous water heater not igniting because water flow rate is too low.	Increase water flow rate through the system. Check inlet filters and clean or replace. Refer to Maintenance section (page 18). Contact the boiler manufacturer.

Guarantee

At Bristan, we want to make things as easy as possible for our customers. That's why we design products that are easy to fit and use, and that are quality tested to make sure they won't let you down. It's also why we offer solid guarantees on all products, effective from the date of purchase, to give you peace of mind.

Bristan's shower valves are covered by a **5 year guarantee**. This also includes **5 years labour cover** * (subject to registration) which means that, in the unlikely event that there is a problem in the first year after purchase, we'll send one of our expert engineers to fix it.

*Labour is provided by an approved Bristan Care engineer or appointed representative. The guarantee only applies to products with a manufacturing fault. There will be a call out charge for any incidents where no fault has been found with the product, or if the issue is due to poor installation or maintenance.

Guarantee Terms and Conditions

This guarantee is in addition to your statutory and other legal rights and is subject to the following conditions:

- The product was purchased within the United Kingdom or Republic of Ireland.
- The guarantee applies solely to the original purchaser with proof of purchase.
- The installation must allow ready access to all products for the purpose of inspection, maintenance or replacement.

- Repair under this guarantee does not extend the original expiry date. The guarantee on any replacement parts or product ends at the original expiry date.
- Any part found to be defective during the guarantee period will be replaced without charge, providing that the product has been installed in accordance with the instructions given in this guide and used as the manufacturer intended.

The guarantee does not cover:

- Damage or defects caused by;
 - General wear and tear (including special non-chrome finishes; components such as filters, seals, 'O' rings and washers)
 - Incorrect installation
 - Repair using non-Bristan parts
 - Accidental or wilful misuse
 - Corrosion and the use of inappropriate cleaning products
 - System debris including the build up of limescale (which can be controlled through regular servicing and maintenance)
- Compensation for loss of use of the product or consequential loss of any kind.

In the interests of continuous product improvement, Bristan reserves the right to alter product specifications without notice.

The Bristan Product Guarantee does not affect your statutory rights as a consumer.

Guarantee

• Need help?

If this product does not function correctly when first used, contact **Bristan Care Customer Service on 0844 701 6273** where our expert team of advisors will be able to offer you help and advice.

• Problems during the guarantee period

In the unlikely event that you encounter any problems with the product during the guarantee period, contact **Bristan Care Customer Service on 0844 701 6273** with your proof of purchase and we will work to resolve the problem quickly.

Bristan Care Customer Support

Bristan customers also benefit from the support of Bristan Care, our comprehensive customer support package which offers:

Technical support hotline

(Tel: 0844 701 6273) with access to fully trained advisers who can offer installation advice, talk you through quick maintenance checks, or recommend the best course of action to fix any problems with a product.

Expert advice

Find easy to follow 'how to' video guides and technical FAQs online at www.bristan.com. Our guides take you step-by-step through many product installations and you can find plenty of easy guides to quick product fixes and servicing.

Spare parts

We hold thousands of spares and we keep them for discontinued products for over seven years. Spares can easily be ordered online at www.bristan.com and are dispatched the same day.

Expert plumbing engineers

If we can't solve the problem over the 'phone or with a spare part, then we'll send out one of our Bristan Care engineers to take a look. Bristan Care engineers provide free support for products that are within guarantee, but are also available to service products that are out of guarantee for a small charge. For details, please call **Bristan Care Customer Service on 0844 701 6273**.

Part Number: FI: SHCVO RA
Issue: D3

BRISTAN

Bristan Group Ltd,
Birch Coppice Business Park
Dordon
Tamworth
Staffordshire
B78 1SG
Web: www.bristan.com
Email: enquire@bristan.com

A Masco Company

Useful contact details:

Customer Service:

0844 7016273

Customer Service Email:

Customercare@bristan.com

Customer Service Fax:

0844 7016275

Reception:

0844 7016274

Join us on...

