

AFTERCARE INSTRUCTIONS

Your fitting has a high quality finish and should be treated with care to preserve the visible surfaces. All surface finishes will wear if not cleaned correctly, the only safe way to clean your mixer is to wipe with a soft damp cloth. Stains can be removed using washing up liquid. All bath cleaning powders and liquids will damage the surface of your fitting even the non-scratch cleaners.

GUARANTEE

All products are manufactured to the highest standards and a 5 year guarantee covers any defect in manufacture. As gold and special effect finishes are softer than chromium plate, special care must be taken when cleaning; a 3 year guarantee covers these finishes.

NOTE: The 5 year guarantee on the valves is invalidated if damaged by any water born debris.

In the interests of continuous product development we reserve the right to alter specification as necessary.

PRODUCT NAME:

TELEPHONE HELPLINE: 0844 701 6273

Bristan Group Ltd
Birch Coppice Business Park
Dordon
Tamworth
Staffordshire
B78 1SG
UK
A Masco Company

Web Site: www.bristan.com
Telephone: 0844 701 6273
Facsimile: 0844 701 6275
Email: enquire@bristan.com

(FI J BASBID)

(Rev. D1)

(H)

Java Basin or Bidet Mixer (with pop-up waste)

Fitting Instructions & Contents List

**Please keep these instructions for future reference
and for the ordering of spare parts**

WATER PRESSURE

This mixer is suitable for use at all supply pressures. However for optimum use both the hot and cold supplies should be reasonably balanced. If the fitting is installed at low pressure (tank fed), then the minimum distance from the outlet of the nozzle to the underside of the cold tank should be approximately 2.0 metres to ensure adequate performance.

This mixer should be installed in compliance with Water Regulations. Where the supplies are unbalanced, i.e. hot water from the cylinder tank/cold from the mains, approved check valves must be fitted in the supply pipes. For further details contact your Local Water Authority.

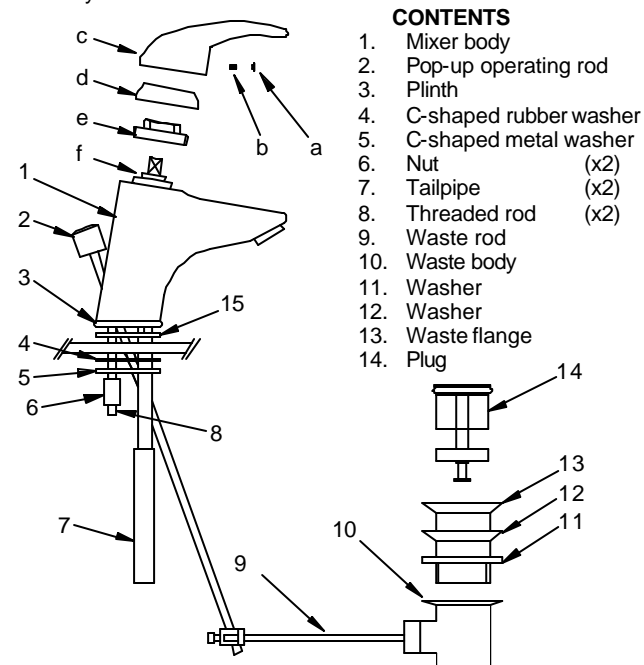

INSTALLATION

1. Identify all components and check for completeness, particularly before arranging fitting.
2. Fit the mixer body (1) to the basin/bidet using the 'C' plate fixing kit. The plinth (3) and 'o' ring (15) go between the fitting and the basin/bidet, and the 'C' shaped rubber (4) and metal washers (5) on the underside of the basin/bidet. Secure into position using threaded rods (8) and nuts (6).
3. Fit the inlet connection tailpipes (7) to the fitting and connect the hot and cold supplies.
4. Fit the pop up waste, using washers (11) below & (12) above the basin/bidet and connect it to the mixer. It is recommended that a silicon sealant be applied to both sealing faces of washers 11 and 12. The waste can be set by adjusting the waste rod (9) / operating rod (2) connecting bracket and the screw in the base of the plug (14).
5. Fully open the mixer in the mid position, letting it run for a few minutes to check all joints and connections for leaks.
6. See over the page for aftercare instructions.

MAINTENANCE

If the fitting begins to drip:

1. Turn off the water supply.
 2. Remove indice cap (a), loosen grub screw (b) with 2.5mm hexagon key and pull off head (c), unscrew shroud (d) retaining nut (e).
 3. Remove cartridge (f).
 4. Clean or replace cartridge, clean and grease seal and refit.
- Note:** that there are locating pins on the bottom of the cartridge that fit in holes inside the tap, to ensure it is fitted the right way round.
5. Replace cartridge and head and turn on the water supply.
 6. Contact our helpline if problem persists.

Please note: In the unlikely event you find a part missing please contact our Customer Service Helpline on 0844 701 6273 or email enquire@bristan.com for immediate dispatch of part.