

## Customer/technical services

For any technical or installation queries please contact Vado on 01934 745163.

## Guarantee

This product is guaranteed against manufacturing defects from the date of purchase until the expiry of the relevant guarantee period shown below.

### The guarantee is only valid if:-

1. The product has been installed, used and maintained in accordance with Vado's instructions and subjected to normal use only.
2. The defect is not due to use of an unsuitable or inadequate water or power supply.
3. The defect is not due to accident, misuse, neglect or repair other than by Vado or Vado authorised agents or damage caused by foreign objects or substances.
4. We have received from you the completed Guarantee Registration Form. Vado accepts no responsibility for any forms lost in the post and returns by registered means is therefore recommended.

Under this guarantee (which is non-transferable) Vado will, at its option, repair or replace free of charge any product (or replacement part) found to be defective. The guarantee does not extend to any consequential loss or damage. After repair or replacement the relevant guarantee period will be calculated from the original date of purchase.

### The relevant guarantee periods are:-

1. Twelve years on chrome finish products.
2. Six years on Vado Identity products.
3. Three years on all other products with the exception of Stuart Turner Pumps which carry a 2 year Guarantee on Monsoon Range and 1 Year Guarantee on Showermate Range.

All claims under the guarantee must be submitted in writing to the person who supplied the product to you and must be received no later than the last day of the relevant guarantee period. All claims must be accompanied by proof of purchase (sales receipt or delivery note).

Vado operates a policy of continuous product development and therefore reserves the right to change the product, packaging and documentation specifications without notice.

This guarantee is in addition to and does not affect your statutory rights as a consumer.

### Vado

Wedmore Road, Cheddar, Somerset, England BS27 3EB  
tel 01934 744466. fax 01934 744345  
technical@vado-uk.com  
www.vado-uk.com

### GUARANTEE REGISTRATION

NAME				
ADDRESS				
	POSTCODE			
RETAILER				
ADDRESS				
	POSTCODE			
PURCHASE DATE	ARTICLE NUMBER	(SEE BOX)		
PRODUCT DESCRIPTION				
WHO INSTALLED THE PRODUCT?	RETAILER	PLUMBER	BUILDER	SELF
FOR VADO USE				



## Installation & maintenance instructions

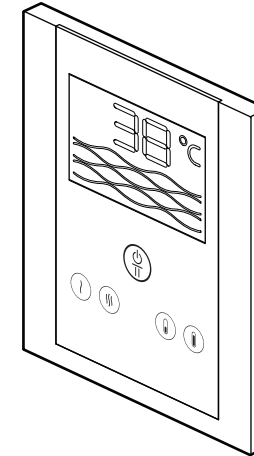

## Identity

### Thermostatic digital shower control panel - wall mounted

If installing product on a pump system, installer must ensure that a negative/universal head pump is used. Failure to comply with this will result in incorrect operation.

**Please leave these instructions with the customer**

## Important - please read

Please read these instructions carefully before starting installation and keep for future reference.

Remove all packaging and check the product for missing parts or damage before starting installation.

Remove all packing materials and dispose of correctly.

To avoid risk of suffocation to children or animals, dispose of the plastic bags correctly.

Any alterations made to this product and fittings may infringe water and electrical regulations and will invalidate the guarantee.

Under no circumstances, should the lid to the control box be removed. Removal of the lid, will invalidate any guarantee and carries risk of shock (240V).

Please note if installing in an enclosed environment, access should be left for servicing and maintenance. No costs relating to inadequate access can be accepted.

**All electrical connections and alterations should be carried out by a qualified electrician and be in compliance with Part P regulations.**

### Electrical Connections

All electrical connections should be carried out by a qualified electrician.

The installation must comply with current NICEIC regulations and to the requirements of BS7671 (Requirements for electrical installations).

Please ensure that all exposed metal is supplementary bonded.

Always switch off the power at the main consumer unit and isolate the electrical supply before making any electrical connections.

This appliance is to be fitted with the relevant RCD protection.

### Plumbing Connections

The installation must comply with all Local/National Water Supply Authority Regulations/Byelaws and Building and Plumbing (UK:BS6700) Regulations.

This mixer valve is suitable for any water system, provided minimum water pressure is met.

Where connections are made to the mains cold water supply, WRC approved single check valves must be fitted to both hot and cold inlets. This is a stated requirement of Water Supply (Water Fittings) Regulations 1999 Schedule 2, Section 6 G15.13.2

Before making any inlet pipe connections, all supply pipes MUST be thoroughly flushed to remove debris. Failure to do so could result in damage or low flow from the mixer unit. Water Supply (Water Fittings) Regulations 1999 Schedule 2 Section 4 G13.1

The fitting of isolating valves to the inlet feeds is advised for ease of maintenance.

Please take great care when installing this mixer not to damage its surface.

Note: When pressure is higher than 5 bar a pressure reducer is required to be fitted before the valve.

## Troubleshooting

Problem	Possible cause	Solution
Outlet water temperature is too cold	<ol style="list-style-type: none"><li>1. Incorrect power rating.</li><li>2. The temperature is set too low</li><li>3. The hot water is not hot enough.</li><li>4. The hot water pressure is lower than the cold.</li><li>5. The cold and hot pipes have been reversed.</li></ol>	<ol style="list-style-type: none"><li>1. Check the supplied AC connections are correct.</li><li>2. Adjust the temperature.</li><li>3. Increase the water inlet temperature.</li><li>4. Increase the hot water pressure or reduce the cold.</li><li>5. Reverse the pipes.</li></ol>
Outlet water temperature is too hot	<ol style="list-style-type: none"><li>1. Incorrect power rating.</li><li>2. The temperature is set too high</li><li>3. The cold water pressure is lower than the hot.</li><li>4. The cold and hot pipes have been reversed.</li></ol>	<ol style="list-style-type: none"><li>1. Check the supplied AC connections are correct.</li><li>2. Adjust the temperature.</li><li>3. Increase the cold water pressure or reduce the hot.</li><li>4. Reverse the pipes.</li></ol>
The red light is flashing	<ol style="list-style-type: none"><li>1. Incorrect power rating.</li><li>2. The product fails to start.</li></ol>	<ol style="list-style-type: none"><li>1. Check the supplied AC connection are correct.</li><li>2. Restart the product. Turn off, wait for 1 minute, then turn on.</li></ol>
Touch buttons fail to operate	<ol style="list-style-type: none"><li>1. No power</li></ol>	<ol style="list-style-type: none"><li>1. Check power supply.</li></ol>

## Care of the mixer

Our products are finished to the highest standard and due care needs to be taken to ensure their looks are retained.

We recommend cleaning all products with a soft damp cloth ONLY and advise strongly against the use of ALL cleaning products i.e. powders and liquids.

If the above instructions are not followed this will invalidate your guarantee in the event of a problem occurring.

## Disposal - please read

### Waste electrical and electronic equipment (WEEE)

The wheeled bin symbol means the product is covered by the European Directive 2002/96/EC.

DO NOT dispose of this unit with normal household waste, take to a local authority recycling centre.



## Operation

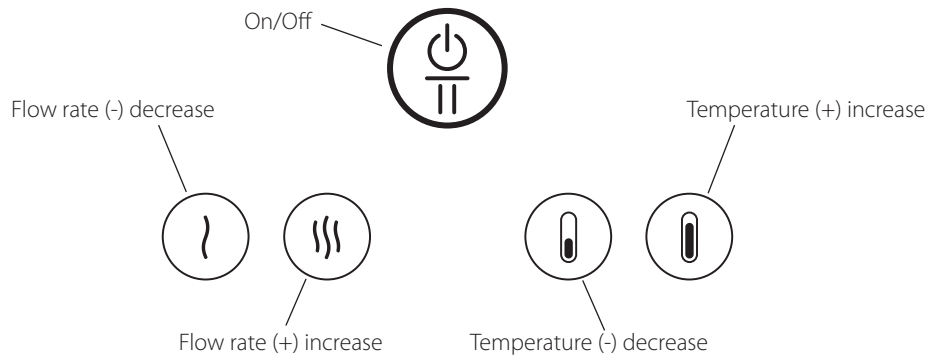

Symbol	Description	Function descriptions
	Flow rate (-)	When switched on - At each touch of the button the flow is decreased accordingly and a buzzer sound is heard.
	Flow rate (+)	When switched on - At each touch of the button the flow is increased accordingly and a buzzer sound is heard.
	On and Off	Each touch of the button switches the mixer on/off, each touch of the button a buzzer is heard. When on the panel LEDs will light accordingly.
	Temperature (-)	When switched on - At each touch of the button the temperature is decreased accordingly and a buzzer sound is heard.
	Temperature (+)	When switched on - At each touch of the button the temperature is increased accordingly and a buzzer sound is heard.

The mixer has 5 steps for the flow control and 25 steps for the temperature control. When the mixer is first commissioned the flow control is set on the 2nd step, and the temperature control on the 3rd step. If no keys have been pressed for 15 minutes the mixer will automatically switch off.

Touch button LED colours	
Light status (colour)	Mixer functions
Red light flashed for 3 seconds	Mixer is starting
Blue colour	Outlet water temperature <34°
Purple colour	Outlet water temperature <40°
Red colour	Outlet water temperature over 40°
Red light flashed for 0.5 seconds	Product has malfunctioned

## Dimensions

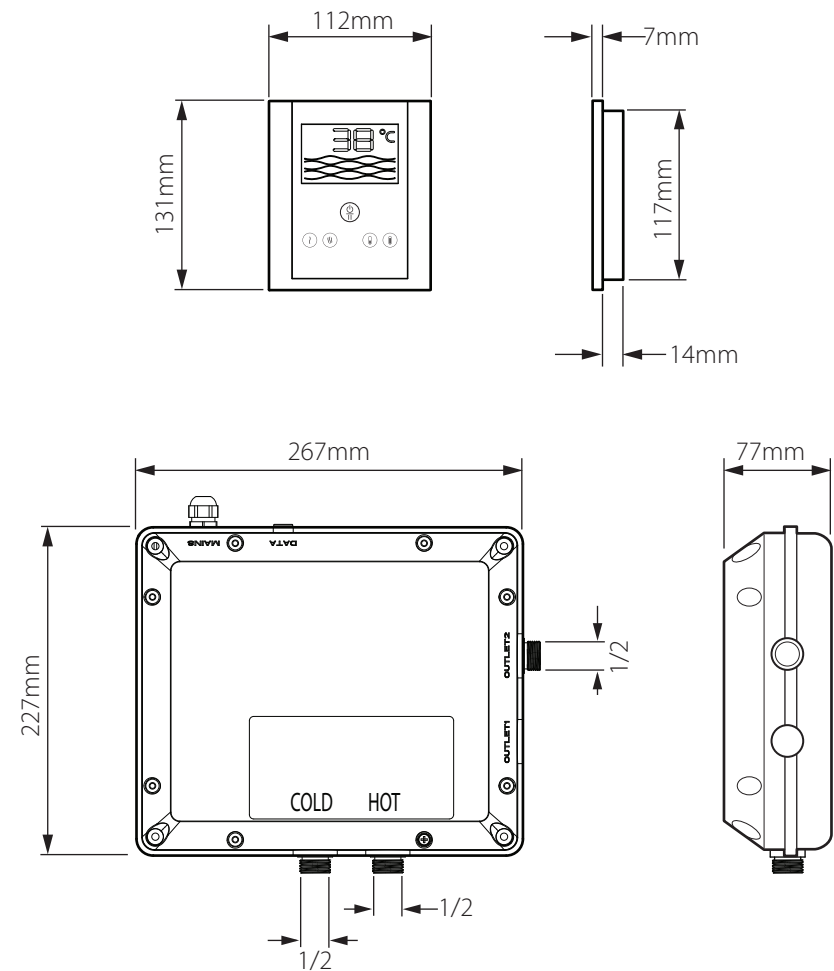

## Operating Specifications

### Plumbing Connections

Minimum operating pressure 1.5 bar  
Maximum operating pressure 5 bar

### Electrical Connections

Rating - 220-240V AC/50Hz  
Maximum power rating 16W

## Installation - control box

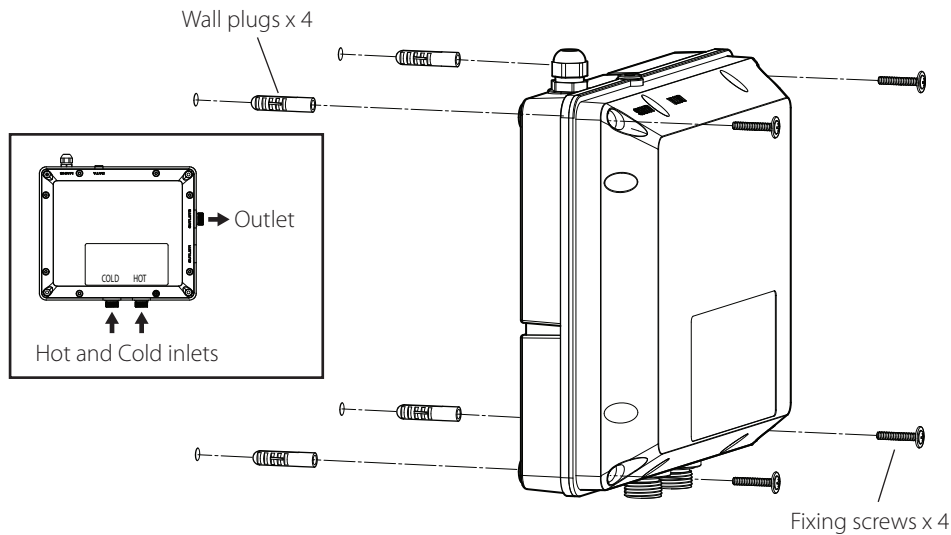

**Warning!** Please check for any hidden cables and pipes before drilling holes in the wall.

The control box should be installed horizontally on the wall (see above). Before fitting control box horizontally to the wall please ensure that hot and cold inlets are at the bottom, with the outlet on the right hand side.

Fix the template supplied to the wall in a suitable dry position under the basin, making sure the flexible pipe from the mixer will reach the Control box.

**Please note:** If installing in a loft space or area susceptible to cold temperatures then adequate steps must be taken to ensure that the box is protected from frost.

Make sure the template is level and mark the position of the 4 screw holes. Using suitable wall fixings for your wall (fittings supplied are for solid walls) drill the 4 marked positions with a suitable drill and insert the wall plugs. Attached the control box to the wall with 28mm supplied screws.

### Plumbing connection

Using the supplied flexible pipes, connect the hot and cold supplies to the control box, according to the indications on the label.

### Mains electrical connection

Connect the control box to the ~230V 50 Hz AC mains supply with a fused switch and an inline RCD outside of the bathroom.

The mains cable can be connected to a 3 or 5 amp plug if required using the following connections.

Brown - (L) Live      Blue - (N) Neutral      Green/yellow - (E) Earth

**Note:** If using a plug and socket the socket must not be installed within the bathroom.

## Installation - control panel

Unclip the cover from the bottom of the control panel and lift away from the top.

In the required position prepare a recess in the wall 98mm x 117mm and by 30mm deep from the final finish wall surface.

Fix the box in position making sure it is level and flush with the finished wall surface.

Bring the end of the extension lead coming from the control box through one of the holes in the box and connect to the lead coming from the control panel. Line up flats on both connectors and push together, screw on the ring to secure together.

Push the connector into the recess and the control panel into the box, secure in position with the 4 x 16mm screws.

Place the cover over the top of the control panel and clip onto the bottom.

