

GRUNDFOS ALPHA2

Circulator pumps
50 Hz

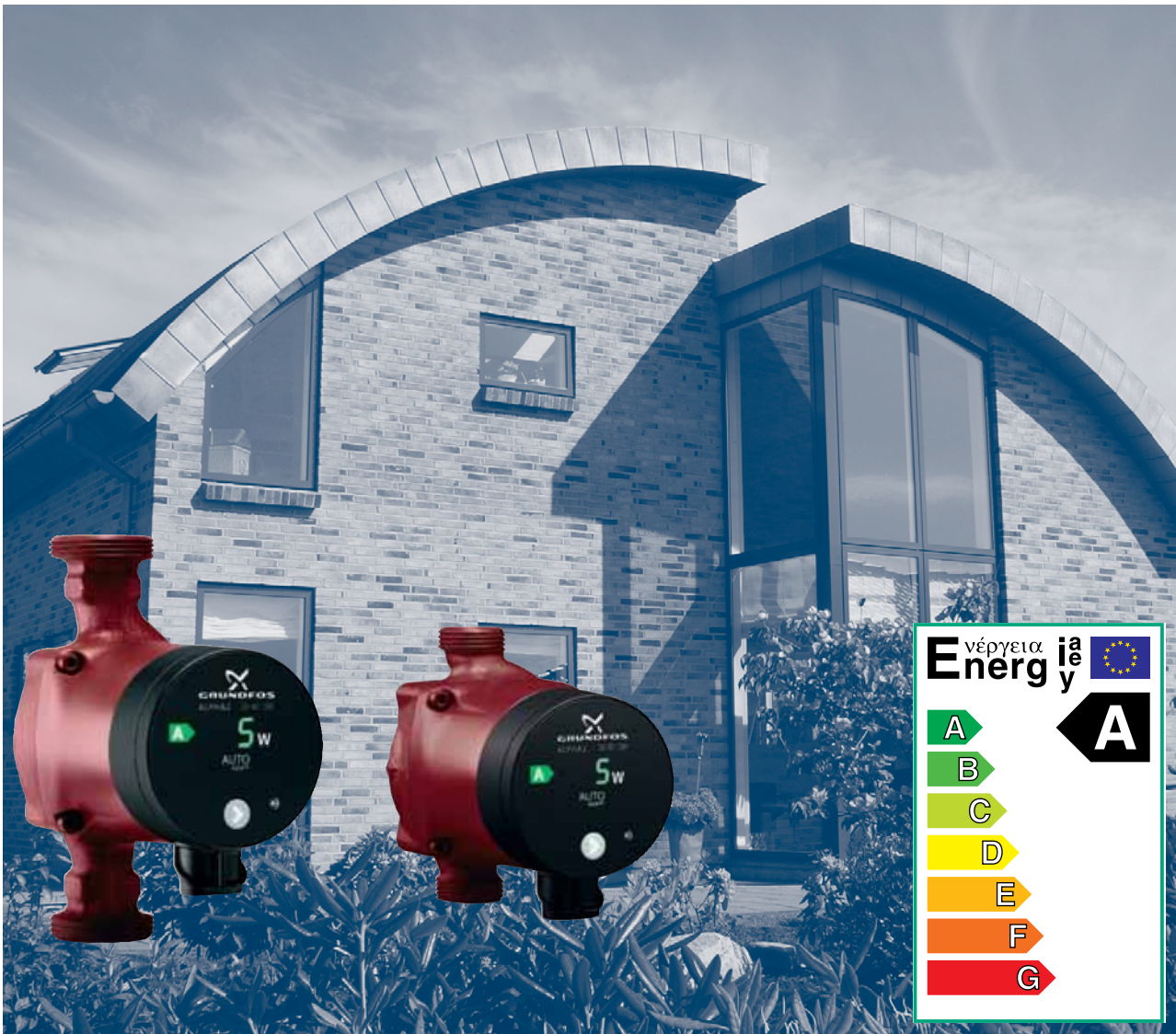

Contents

General data

Circulator pumps	3
Type key	3
Performance range	3
Applications	4
Pumped liquids	4
Control of heating systems	5
AUTOADAPT	5
Operation	5
Advantages of pump control	5
Automatic Night SetBack	6
Construction	7
Sectional drawing	7
Material specification	7
Motor and control box	7
Pump housing with air separator	8
Installation	9
Electrical data	9
Start-up	9
Liquid temperature	9
System pressure	9
Inlet pressure	9
Setting of pump head	9
Factory setting	9
Change of performance	10
Guide to performance curves	11
Curve conditions	12

Technical data

Accessories

Union and valve kits	18
Insulation kits	18
Service kit	18

Further product documentation

WebCAPS	19
WinCAPS	20

Circulator pumps

GRUNDFOS ALPHA2 is a complete range of circulator pumps featuring:

- AUTOADAPT function which suits most installations.
- Integrated differential-pressure control enabling adjustment of pump performance to the actual system requirements.
- Automatic Night SetBack (selectable).
- Display showing the actual power consumption in Watt.
- Motor based on permanent-magnet/compact-rotor technology.

GRUNDFOS ALPHA2 is energy-optimised and A-labelled.

The energy label A indicates the energy-saving level of the pump. The energy classification system has seven levels, i.e. from A to G. Level A is the best.

The installation of a GRUNDFOS ALPHA2 pump will reduce the power consumption considerably, reduce noise from thermostatic valves and similar fittings, and improve the control of the system.

GRUNDFOS ALPHA2 offers a host of advantages:

- Energy savings** Automatic control of the differential pressure.
- Flexibility** Suitable for installation in existing systems.
- Night setback** Automatic Night SetBack (selectable).
- Comfort** Low-noise operation.
- Safety** Built-in electrical and thermal protection of the pump.
- Userfriendliness** Simple setting and operation.

Type key

Example	ALPHA2	25 - 40	180
Pump range			
Nominal diameter (DN) of suction and discharge ports [mm]			
Maximum head [dm]			
: Cast-iron pump housing			
N: Stainless-steel pump housing			
A: Pump housing with air separator			
Port-to-port length [mm]			

Performance range

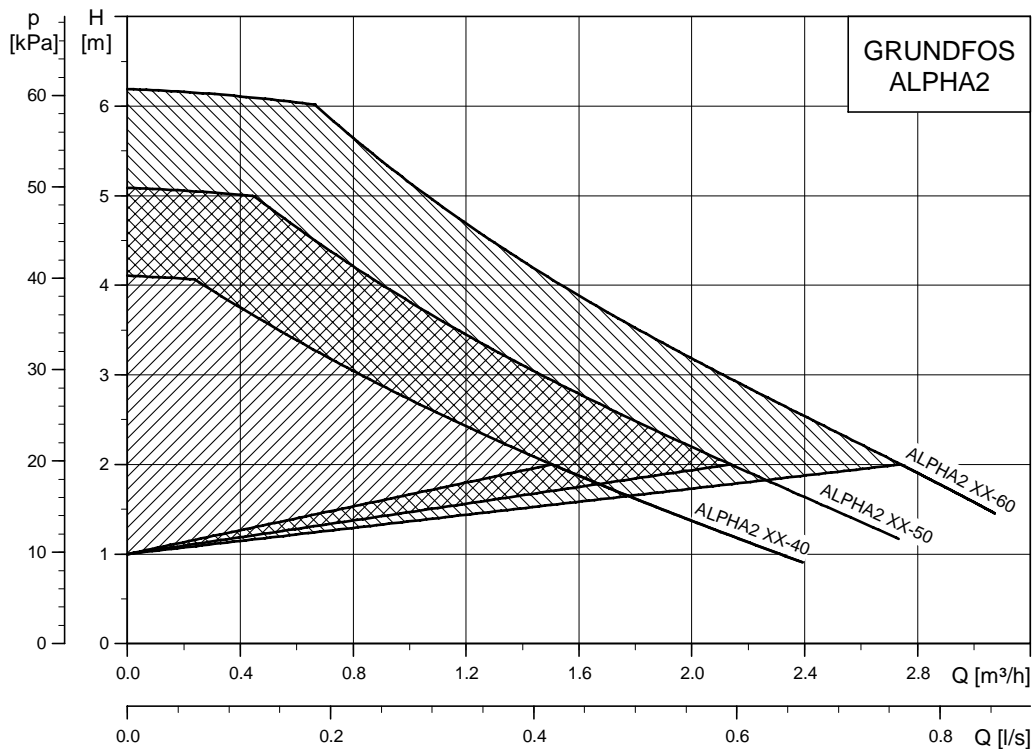

Fig. 1 Performance range, ALPHA2

TM03 9502 4107

Applications

GRUNDFOS ALPHA2 is designed for circulating liquids in heating systems. Pumps with stainless-steel pump housing can also be used in domestic hot-water systems.

GRUNDFOS ALPHA2 is suitable for

- systems with **constant** or **variable flows** where it is desirable to optimise the pump duty point.
- systems with **variable flow-pipe temperature**.
- systems where night setback is desired.

GRUNDFOS ALPHA2 is especially suitable for

- installation in existing systems where the differential pressure of the pump is too high during periods of reduced flow demand.
- installation in new systems for fully automatic adjustment of the performance to flow demands without the use of bypass valves or similar expensive components.

Examples of systems

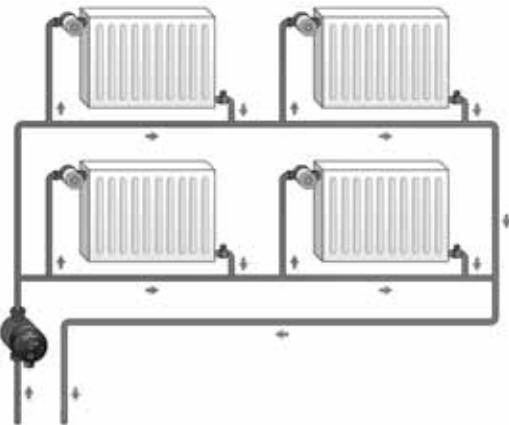

Fig. 2 One-pipe heating system

TM03 8990 4507

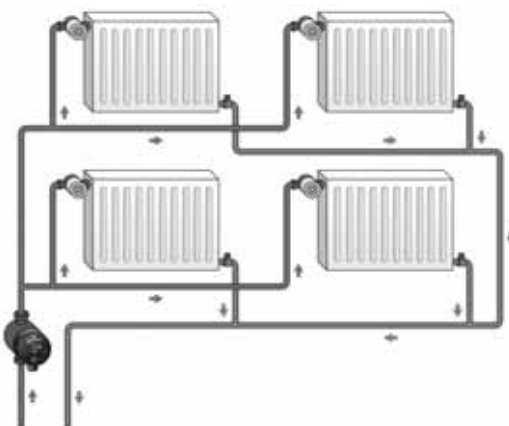

Fig. 3 Two-pipe heating system

TM03 8989 4507

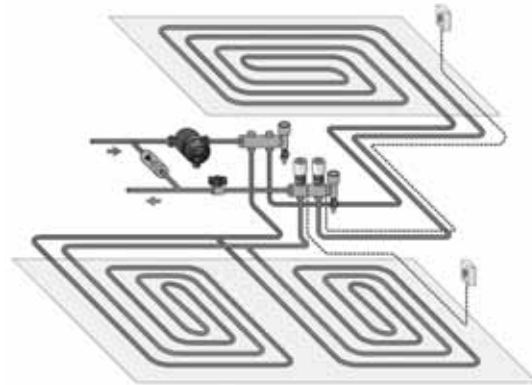

Fig. 4 Underfloor heating system

TM03 9890 4507

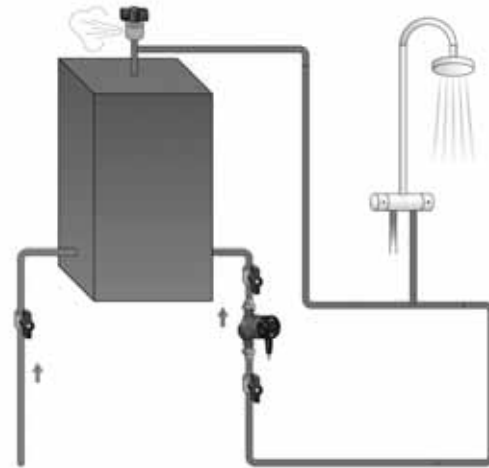

Fig. 5 Domestic hot-water system

TM03 9887 4507

Pumped liquids

Clean, thin, non-aggressive and non-explosive liquids, not containing solid particles, fibres or mineral oil.

The pump must not be used for the transfer of flammable liquids such as diesel oil, petrol and similar liquids.

Control of heating systems

The heating required in a building varies greatly during the day due to changing outdoor temperatures, solar radiation and heat emanating from human beings, electric appliances, etc.

Add to this that the need for heating may vary from one section of the building to another and that the thermostatic valves of some radiators may be turned down by the users.

These circumstances will cause an uncontrolled pump to produce a too high differential pressure when the heating demand is low.

Possible consequences:

- too high energy consumption
- irregular control of the system
- noise in thermostatic valves and similar fittings.

GRUNDFOS ALPHA2 automatically controls the differential pressure by adjusting the pump performance to the actual heating demand, without the use of external components.

AUTOADAPT

The integrated AUTOADAPT function is especially developed for

- underfloor heating systems
- two-pipe systems.

The AUTOADAPT function (factory setting) automatically adjusts the pump performance to the demand, i.e. the size of the system and the heating demand. The performance is adjusted gradually over time. An optimum pump setting cannot be expected from day one.

Operation

The AUTOADAPT function enables the ALPHA2 to control the pump performance automatically:

- Adjustment of the pump performance to the heating demand of the system.
- Adjustment of the pump performance to the variations in load over 24 hours.

In AUTOADAPT mode, the pump is set to proportional-pressure control.

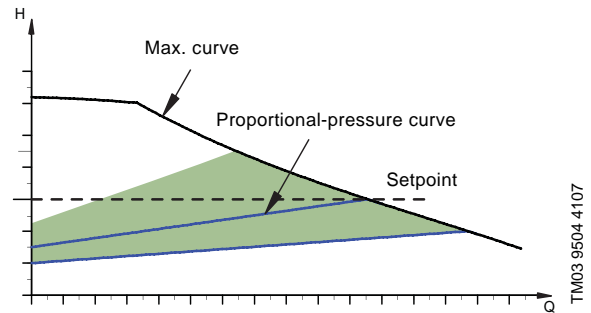

Fig. 6 AUTOADAPT performance range

The AUTOADAPT function differs from other control functions as it moves the control curve within a performance range. The shaded area indicates the limits for the movement of the proportional-pressure curve. See fig. 6.

Advantages of pump control

In GRUNDFOS ALPHA2, control is effected by adapting the differential pressure to the flow (proportional- and constant-pressure control).

Contrary to an uncontrolled pump, the proportional-pressure-controlled GRUNDFOS ALPHA2 reduces the differential pressure as a result of falling heating demand.

If the heating demand falls - for instance due to solar radiation - the radiator valves will close, and, for the uncontrolled pump, the flow resistance of the system will rise for instance from A_1 to A_2 .

In a heating system with an uncontrolled pump, this situation will cause a pressure rise in the system by ΔH_1 .

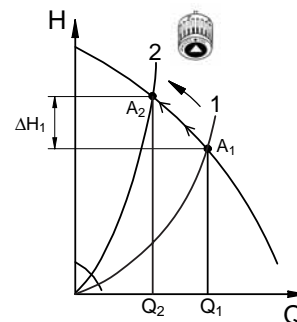
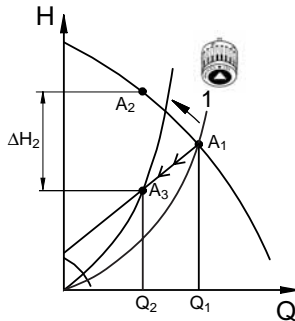

Fig. 7 Uncontrolled pump

TM03 9504 4107

TM01 9119 5002

In a system with a GRUNDFOS ALPHA2 pump, the pressure will be reduced by ΔH_2 .



TM01 9120 5002

Fig. 8 Pump in proportional-pressure control mode

In a system with an uncontrolled pump, a pressure rise will often cause flow-generated noise in the thermostatic valves. This noise will be reduced considerably with the GRUNDFOS ALPHA2.

Automatic Night SetBack

GRUNDFOS ALPHA2 features selectable Automatic Night SetBack.

Automatic Night SetBack is activated with the  button on the control box.

Factory setting of Automatic Night SetBack: Not active.

Note: If the pump has been set to speed I, II or III, the night setback function is deactivated.

Once Automatic Night SetBack has been activated, the pump automatically changes between normal duty and night setback. Changeover is dependent on the flow-pipe temperature measured by the integrated temperature sensor.

Construction

GRUNDFOS ALPHA2 is of the canned-rotor type, i.e. pump and motor form an integral unit without shaft seal and with only two gaskets for sealing. The bearings are lubricated by the pumped liquid.

The pump is characterised by

- integrated AUTO_{ADAPT} control
- integrated proportional-pressure control
- integrated constant-pressure control
- three fixed-speed curves
- frequency converter
- permanent-magnet/compact-stator motor
- display showing the actual pump power consumption in Watt (in whole numbers)
- ceramic shaft and radial bearings
- carbon thrust bearing
- stainless-steel rotor can, bearing plate and rotor cladding
- composite impeller
- cast-iron or stainless-steel pump housing
- compact design featuring pump head with integrated control box and control panel.

Sectional drawing

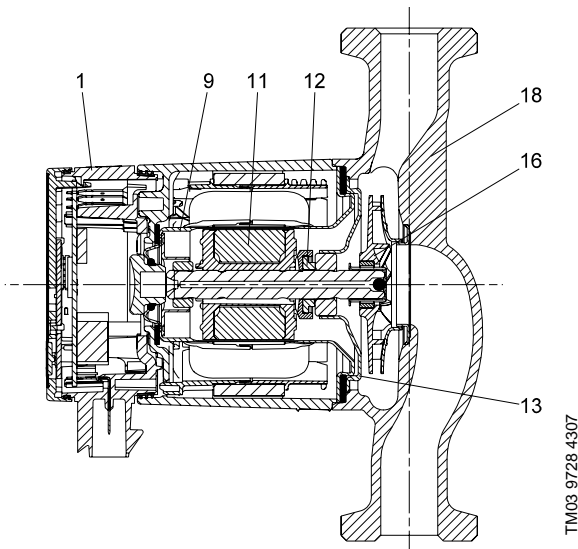

Fig. 9 Position numbers

Material specification

Pos.	Description	Material	EN/DIN W.-Nr.	AISI/ASTM
1	Controller complete	Composite, PC		
9	Rotor can	Stainless steel	1.4301	304
	Radial bearing	Ceramics		
11	Shaft	Ceramics		
	Rotor cladding	Stainless steel	1.4301	304
12	Thrust bearing	Carbon		
	Thrust bearing retainer	EPDM rubber		
13	Bearing plate	Stainless steel	1.4301	304
16	Impeller	Composite, PP or PES		
18	Pump housing	Cast iron	EN-JL 1020	A48-25
		Stainless steel	EN 1.4308	B
	Gaskets	EPDM rubber		

Motor and control box

The motor is a 4-pole synchronous permanent-magnet motor.

The pump controller is incorporated in the control box, which is fitted to the stator housing with two screws and connected to the stator via a terminal plug.

The control box has an integrated control panel with two push-buttons (see pos. 1 and 2) and a 2-digit 7-segment display.

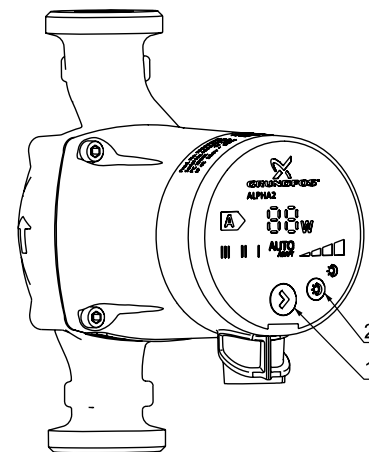

Fig. 10 Push-button positions

- Push-button (pos. 1) for selection of control mode.
- Push-button (pos. 2) for activation or deactivation of Automatic Night SetBack.

The light in the display is on when the electricity supply has been switched on. During operation, the display shows the actual pump power consumption in Watt (in whole numbers). Accuracy: ± 5 %.

Faults preventing the pump from operating properly (e.g. blocking) are indicated in the display by "- -".

Possible control box positions:

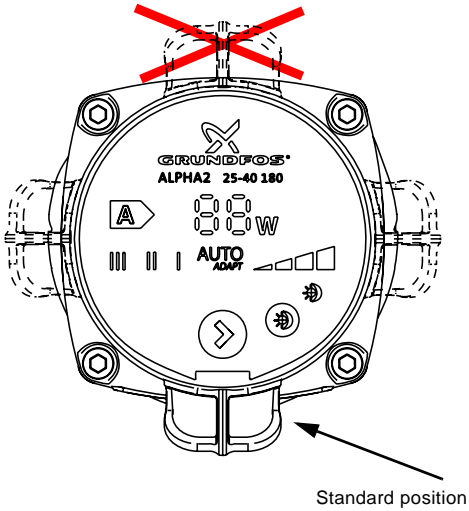

Fig. 11 Control box positions

The cable entry incorporates cable relief.

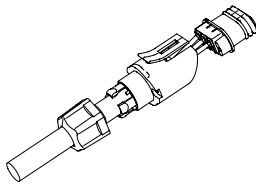

Fig. 12 Cable entry with cable relief

Pump housing with air separator

The pump housing with air separator is installed in systems where the liquid contains so much air that a circulator pump without air separator cannot start or keep up a continuous circulation. The pump housing is available only for upward water flows.

The air-containing liquid is guided from the suction port to the nozzle of the air-separating chamber and caused to circulate considerably in the relatively large chamber, thus creating a relatively lower pressure at the back (top) of the chamber. This lower pressure combined with the reduced velocity of the liquid in the air-separating chamber will cause a separation of air from the liquid. Due to its lower density, the air will escape through an automatic air vent fitted to the air-separating chamber.

The pump housing has an Rp 3/8 tapping for fitting of an air vent. The air vent is not supplied with the pump.

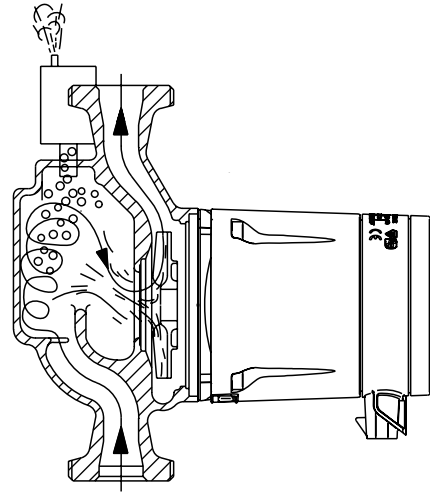

Fig. 13 Pump housing with air-separating chamber

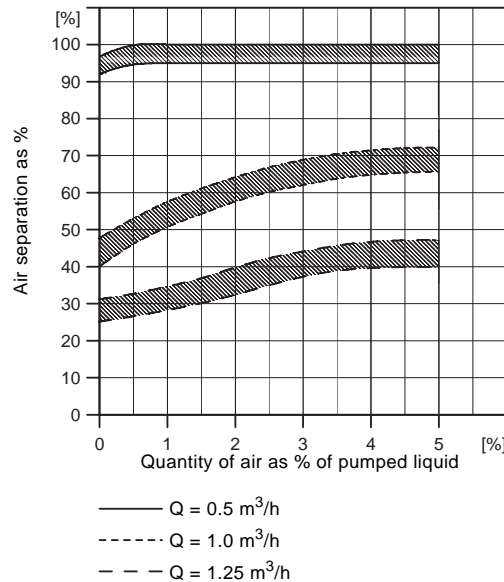

Fig. 14 Air separation

Installation

In most cases, the installation of the ALPHA2 is reduced to the mechanical installation and the connection to the electricity supply.

The pump must always be installed with horizontal motor shaft.

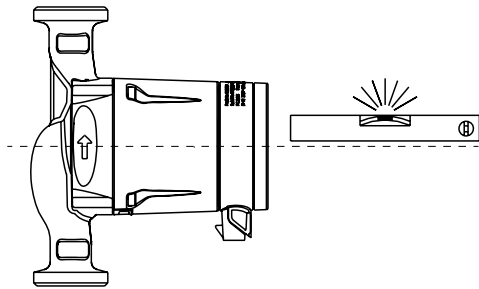

Fig. 15 Horizontal motor shaft

TM03 8501 1707

Electrical data

Supply voltage	1 x 230 V – 10 %/+ 6 %, 50 Hz, PE
Motor protection	The pump requires no external motor protection.
Enclosure class	IP 42
Insulation class	F
Relative air humidity	Maximum 95 %
Ambient temperature	0 °C to +40 °C
Temperature class	TF110 to CEN 335-2-51
EMC (electromagnetic compatibility)	EN 61000-6-2 and EN 61000-6-3
Sound pressure level	≤43 dB(A)

Start-up

The pump must not be started until the system has been filled with liquid and vented. Furthermore, the required minimum inlet pressure must be available at the pump inlet. The system cannot be vented through the pump.

The pump is self-venting. It need not be vented before start-up.

Liquid temperature

Cast-iron pumps: +2 °C to +110 °C.

Stainless-steel pumps in domestic hot-water systems: +15 °C to +65 °C.

In domestic hot-water systems, it is recommended to keep the liquid temperature below 65 °C to eliminate the risk of lime precipitation.

To avoid condensation in the control box and stator, the liquid temperature must always be higher than the ambient temperature. See table.

Ambient temperature [°C]	Liquid temperature	
	Min. [°C]	Max. [°C]
0	2	110
10	10	110
20	20	110
30	30	110
35	35	90
40	40	70

System pressure

PN 10: Maximum 1.0 MPa (10 bar).

Inlet pressure

To avoid cavitation noise and damage to the pump bearings, the following minimum pressures are required at the pump suction port.

Liquid temperature		
75 °C	90 °C	110 °C
0.5 m head	2.8 m head	10.8 m head

Setting of pump head

With the push-button on the control box, the electronically controlled pump can be set to the following:

- AUTOADAPT operating area
- two constant-pressure curves
- two proportional-pressure curves
- three fixed-speed curves.

Factory setting

The push-button on the pump control box is factory-set as shown in the table below.

This setting is suitable for a large majority of all single-family houses.

Pump type	Setting	Automatic Night Setback
ALPHA2 xx-40 ALPHA2 xx-50 ALPHA2 xx-60	AUTOADAPT	Deactivated

Change of performance

The pump performance (flow and head) can be changed by pressing the control box push-button as indicated in the table below and fig. 16.

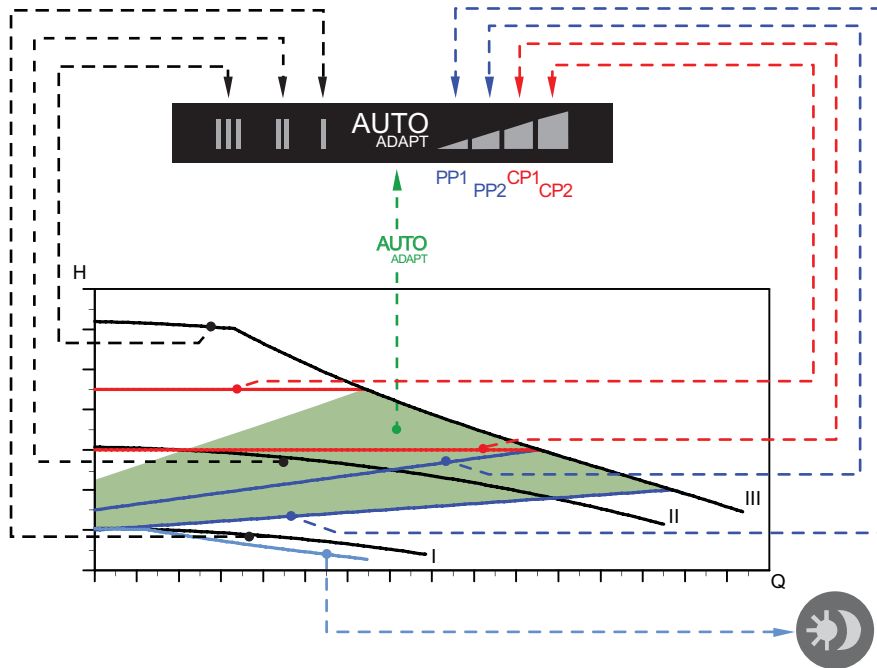

TM03 9208 3607

Fig. 16 Pump setting in relation to performance

Setting	Pump curve	Function
AUTOADAPT (factory setting)	Highest to lowest proportional-pressure curve	The AUTOADAPT function enables ALPHA2 to control the pump performance automatically within a defined performance range, see fig. 16: <ul style="list-style-type: none"> Adjusting the pump performance to the size of the system. Adjusting the pump performance to the variations in load over time. In AUTOADAPT, the pump is set to proportional-pressure control.
PP1	Lowest proportional-pressure curve	The duty point of the pump will move up or down on the lowest proportional-pressure curve, see fig. 16, depending on the heat demand. The head (pressure) is reduced at falling heat demand and increased at rising heat demand.
PP2	Highest proportional-pressure curve	The duty point of the pump will move up or down on the highest proportional-pressure curve, see fig. 16, depending on the heat demand. The head (pressure) is reduced at falling heat demand and increased at rising heat demand.
CP1	Lowest constant-pressure curve	The duty point of the pump will move out or in on the lowest constant-pressure curve, see fig. 16, depending on the heat demand in the system. The head (pressure) is kept constant, irrespective of the heat demand.
CP2	Highest constant-pressure curve	The duty point of the pump will move out or in on the highest constant-pressure curve, see fig. 16, depending on the heat demand in the system. The head (pressure) is kept constant, irrespective of the heat demand.
III	Speed III	ALPHA2 runs at a constant speed and consequently on a constant curve. In speed III, the pump is set to run on the max. curve under all operating conditions. See fig. 16. Quick venting of the pump can be obtained by setting the pump to speed III for a short period. See 6.2 Installation and operating instructions.
II	Speed II	ALPHA2 runs at a constant speed and consequently on a constant curve. In speed II, the pump is set to run on the medium curve under all operating conditions. See fig. 16.
I	Speed I	ALPHA2 runs at a constant speed and consequently on a constant curve. In speed I, the pump is set to run on the min. curve under all operating conditions. See fig. 16.
		ALPHA2 changes to the curve for Automatic Night SetBack, i.e. absolute minimum performance and power consumption, provided certain conditions are met. See Automatic Night SetBack.

Guide to performance curves

Each pump setting has its own performance curve (Q/H curve). However, AUTOADAPT covers a performance range.

A power curve (P1 curve) belongs to each Q/H curve. The power curve shows the pump power consumption (P1) in Watt at a given Q/H curve.

The P1 value corresponds to the value that can be read from the pump display, see fig. 17.

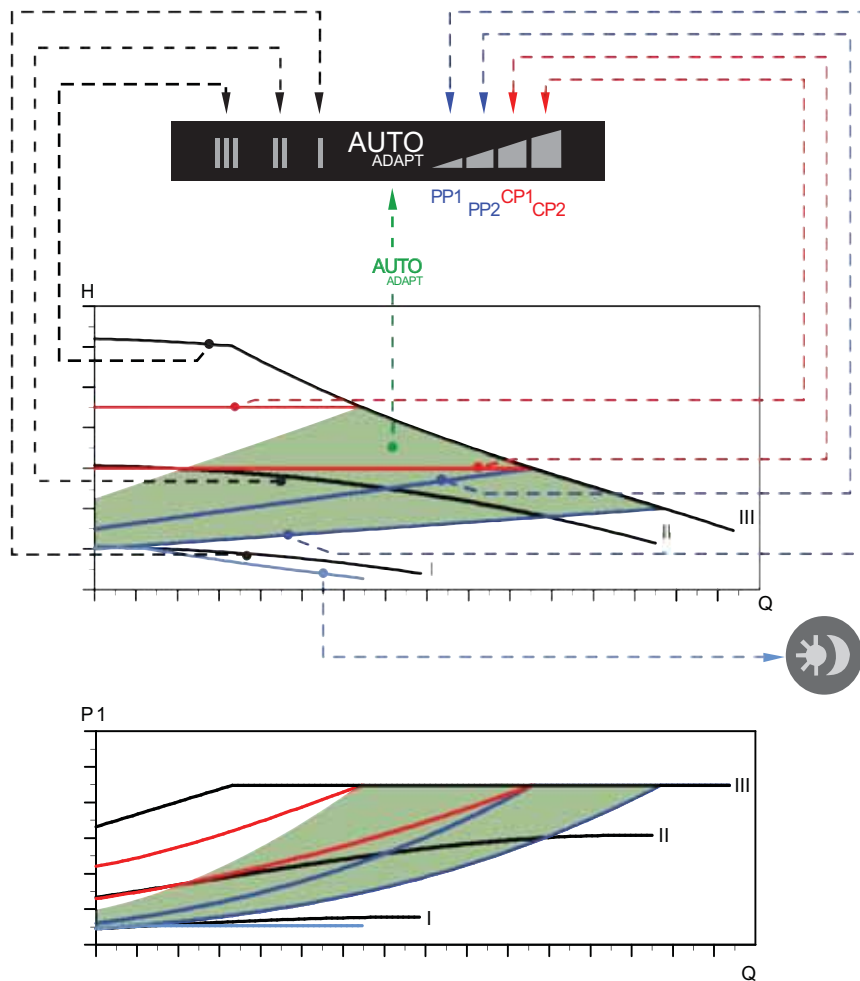



Fig. 17 Performance curves in relation to pump setting

Setting	Pump curve
AUTOADAPT (factory setting)	Setpoint within the shaded area
PP1	Lowest proportional-pressure curve
PP2	Highest proportional-pressure curve
CP1	Lowest constant-pressure curve
CP2	Highest constant-pressure curve
III	Constant speed, speed III
II	Constant speed, speed II
I	Constant speed, speed I
	Curve for Automatic Night SetBack

TM03 9161 3507

Curve conditions

The guidelines below apply to the performance curves on the next pages:

- Test liquid: airless water.
- The curves apply to a density of $\rho = 983.2 \text{ kg/m}^3$ and a liquid temperature of $+60 \text{ }^\circ\text{C}$.
- All curves show average values and **should not be used as guarantee curves**. If a specific minimum performance is required, individual measurements must be made.
- The curves for the speeds I, II and III are marked.
- The curves apply to a kinematic viscosity of $\nu = 0.474 \text{ mm}^2/\text{s}$ (0.474 cSt).
- The conversion between head H [m] and pressure p [kPa] has been made for water with a density of $\rho = 1000 \text{ kg/m}^3$. For liquids with other densities, e.g. hot water, the discharge pressure is proportional to the density.

ALPHA2 15-40, 25-40, 32-40

1 x 230 V, 50 Hz

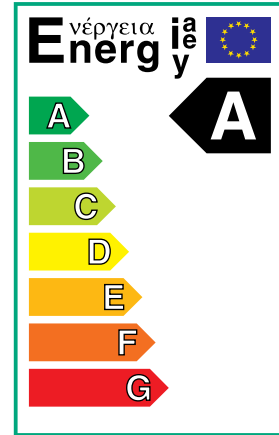
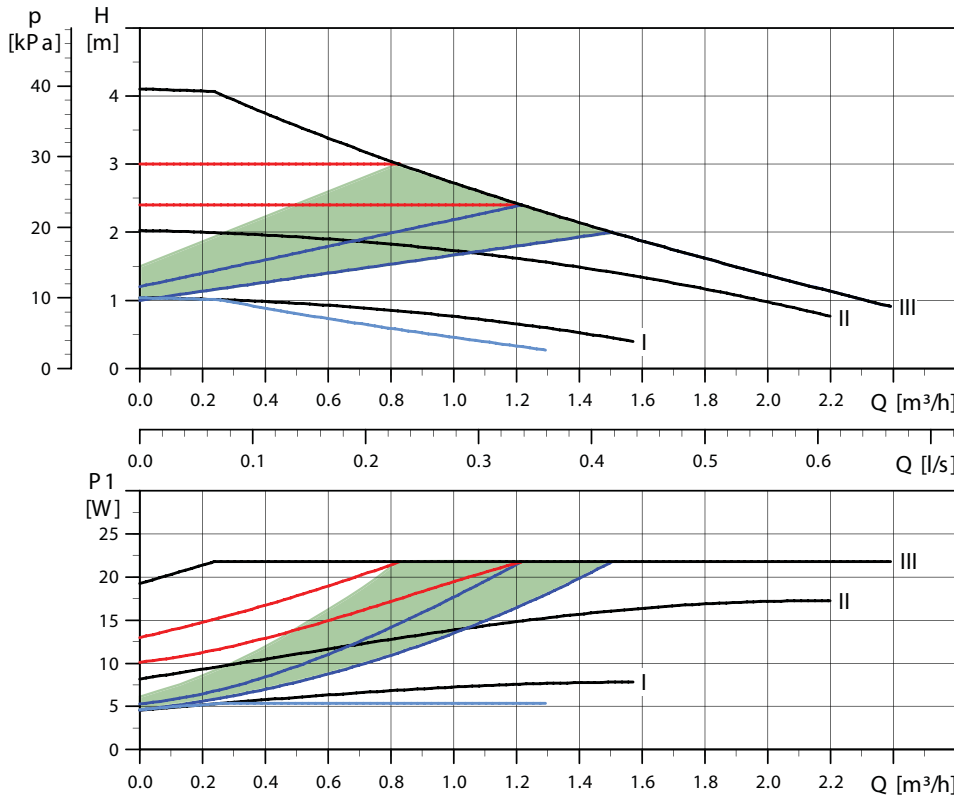

TM03 9083 3307 - TM03 0668 0705

Speed	P ₁ [W]	I _{1/1} [A]
Min.	5	0.05
Max.	22	0.19

The pump incorporates overload protection.

Connections: See "Union and valve kits" on page 18.
 System pressure: Max. 1.0 MPa (10 bar).
 Liquid temperature: +2 °C to +110 °C (TF 110).
 Also available with: Stainless-steel pump housing, type N (only ALPHA2 25-40 N 180).

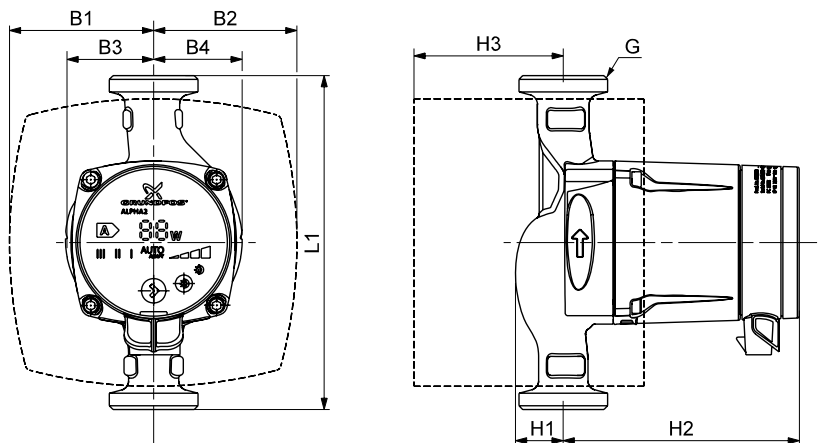

TM03 9215 3607

Pump type	Dimensions [mm]									Weights [kg]		Ship. vol. [m ³]
	L1	B1	B2	B3	B4	H1	H2	H3	G	Net	Gross	
ALPHA2 15-40	130	77	78	46	49	27	129	79	1	1.9	2.1	0.00383
ALPHA2 25-40	130	77	78	46	49	27	129	79	1 1/2	1.9	2.1	0.00383
ALPHA2 25-40 (N)	180	78	77	47	48	26	127	81	1 1/2	2.1	2.3	0.00383
ALPHA2 32-40	180	78	77	47	48	26	127	81	2	2.1	2.3	0.00383

ALPHA2 25-50

1 x 230 V, 50 Hz

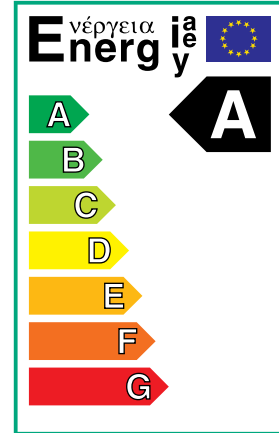
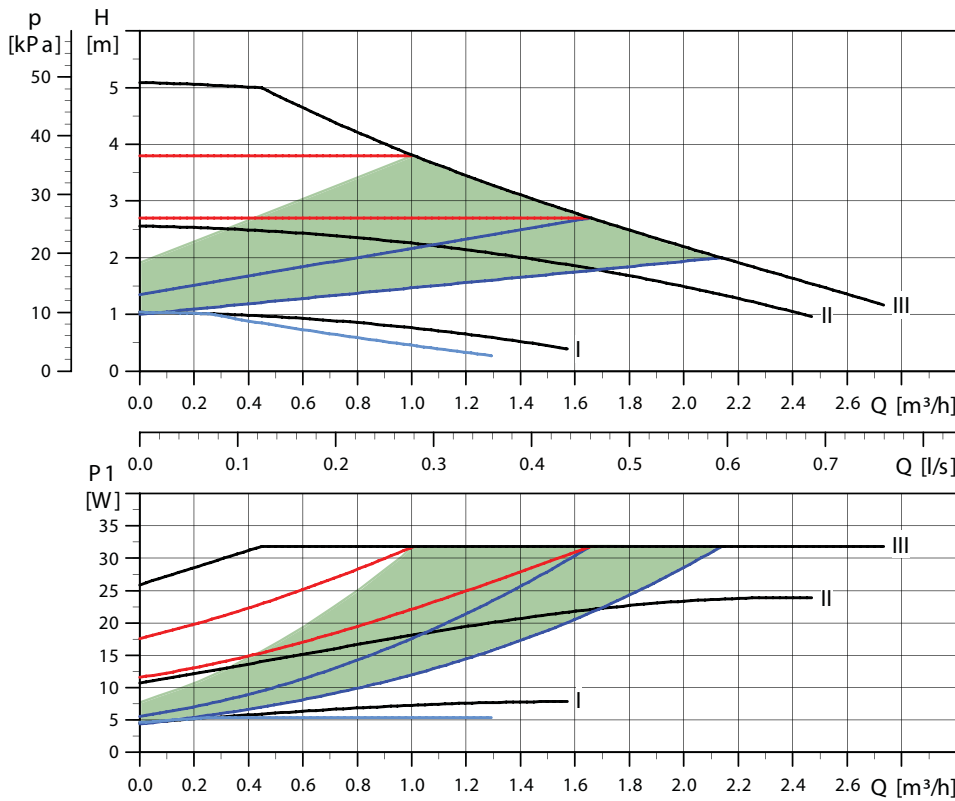

TM03 9084 3307 - TM03 0868 0705

Speed	P ₁ [W]	I _{1/1} [A]
Min.	5	0.05
Max.	32	0.27

Connections: See "Union and valve kits" on page 18.
 System pressure: Max. 1.0 MPa (10 bar).
 Liquid temperature: +2 °C to +110 °C (TF 110).

The pump incorporates overload protection.

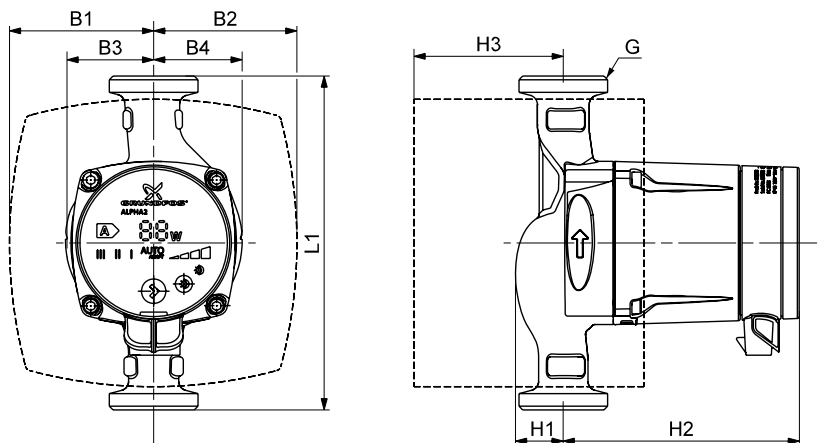

TM04 9215 3607

Pump type	Dimensions [mm]									Weights [kg]		Ship. vol. [m ³]
	L1	B1	B2	B3	B4	H1	H2	H3	G	Net	Gross	
ALPHA2 25-50	130	77	78	46	49	27	129	79	1 1/2	1.9	2.1	0.00383
ALPHA2 25-50	180	78	77	47	48	26	127	81	1 1/2	2.1	2.3	0.00383

ALPHA2 15-60, 25-60, 32-60

1 x 230 V, 50 Hz

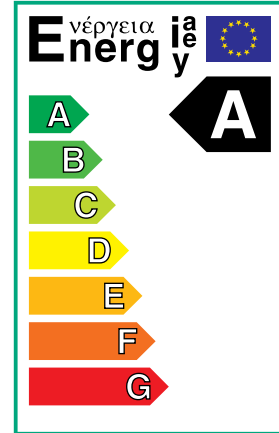
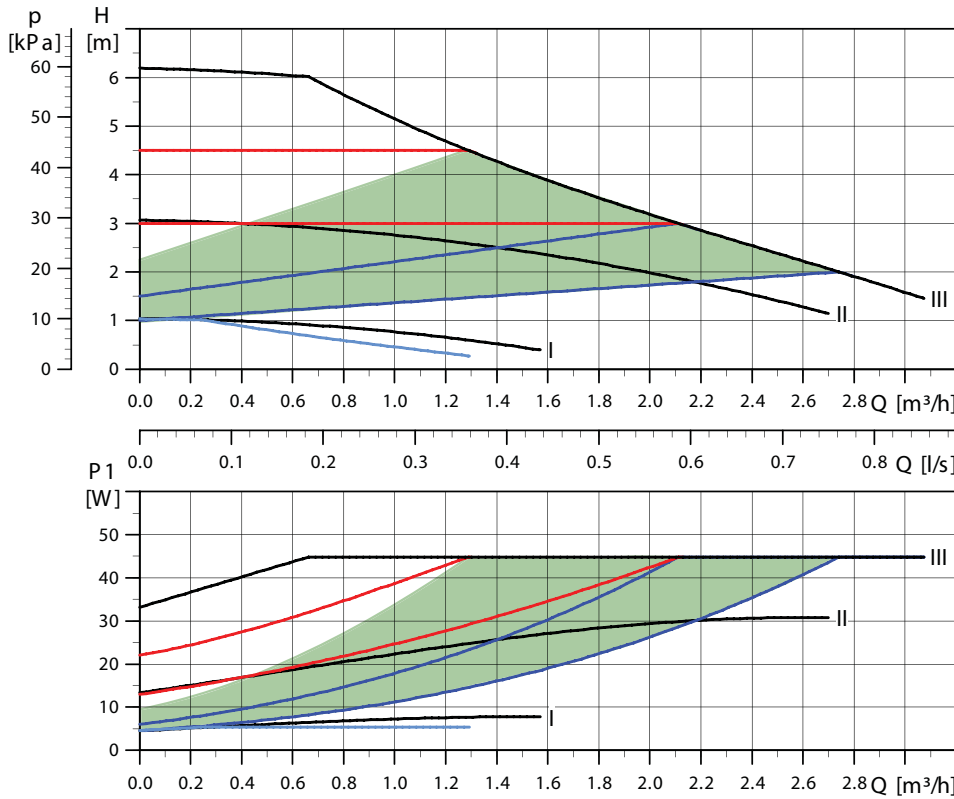

TM03 9085 3307 - TM03 0868 0705

Speed	P ₁ [W]	I _{1/I1} [A]
Min.	5	0.05
Max.	45	0.38

The pump incorporates overload protection.

Connections: See "Union and valve kits" on page 18.
 System pressure: Max. 10 bar.
 Liquid temperature: +2 °C to +110 °C (TF 110).
 Also available with: Stainless-steel pump housing, type N (only ALPHA2 25-60 N 180).

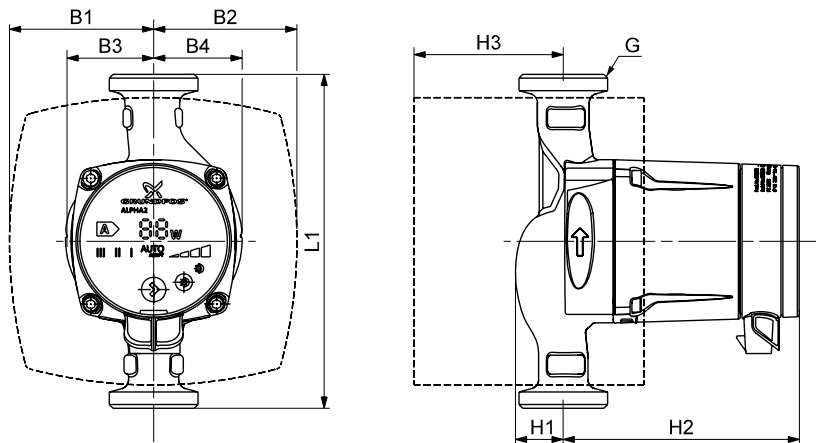

TM03 9215 3607

Pump type	Dimensions [mm]									Weights [kg]		Ship. vol. [m³]
	L1	B1	B2	B3	B4	H1	H2	H3	G	Net	Gross	
ALPHA2 15-60	130	77	78	46	49	27	129	79	1	1.9	2.1	0.00383
ALPHA2 25-60	130	77	78	46	49	27	129	79	1 1/2	1.9	2.1	0.00383
ALPHA2 25-60 (N)	180	78	77	47	48	26	127	81	1 1/2	2.1	2.3	0.00383
ALPHA2 32-60	180	78	77	47	48	26	127	81	2	2.1	2.3	0.00383

ALPHA2 25-40 A

1 x 230 V, 50 Hz

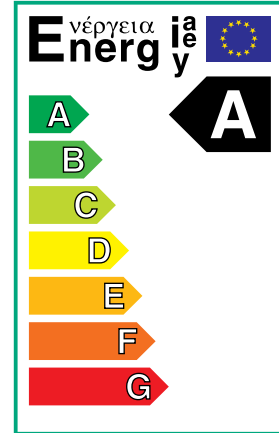
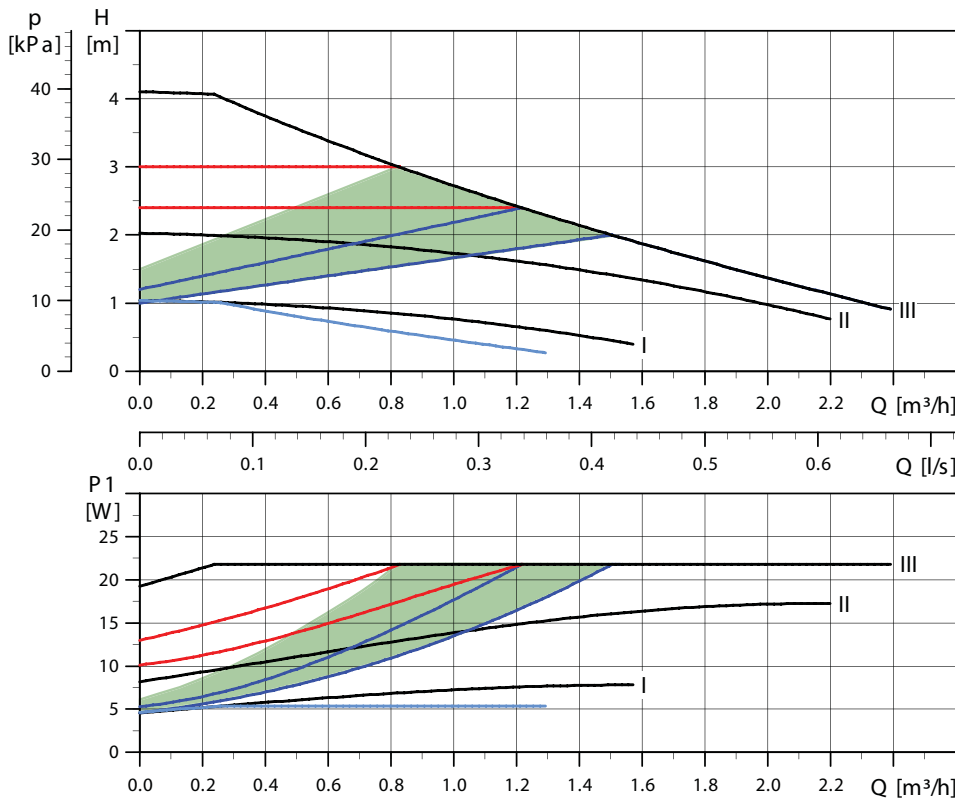

TM03 9083 3307 - TM03 0868 0705

Speed	P ₁ [W]	I _{1/1} [A]
Min.	5	0.05
Max.	22	0.19

Connections: See "Union and valve kits" on page 18.
 System pressure: Max. 1.0 MPa (10 bar).
 Liquid temperature: +2 °C to +110 °C (TF 110).

The pump incorporates overload protection.

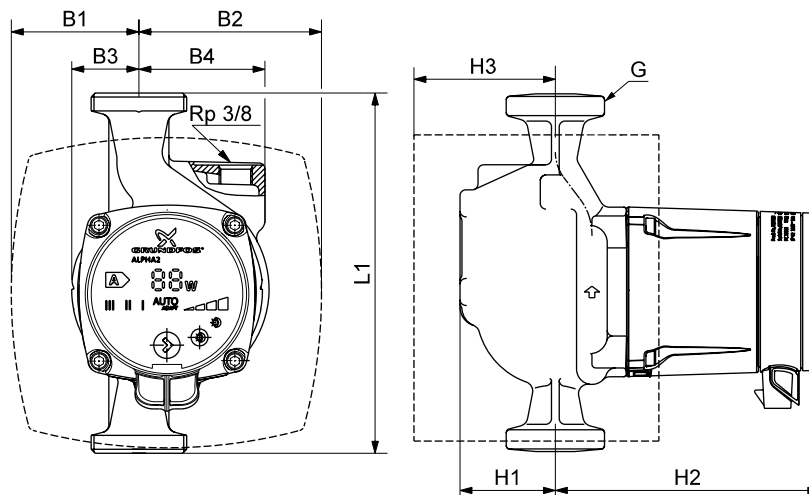

TM03 9211 3607

Pump type	Dimensions [mm]									Weights [kg]		Ship. vol. [m ³]
	L1	B1	B2	B3	B4	H1	H2	H3	G	Net	Gross	
ALPHA2 25-40 A	180	64	91	34	65	50	137	71	1 1/2	3.1	3.3	0.0063

ALPHA2 25-60 A

1 x 230 V, 50 Hz

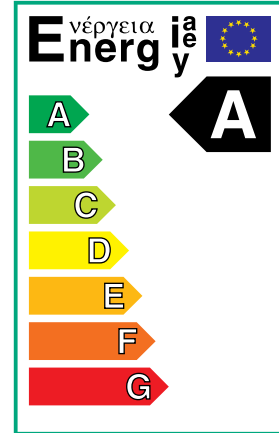
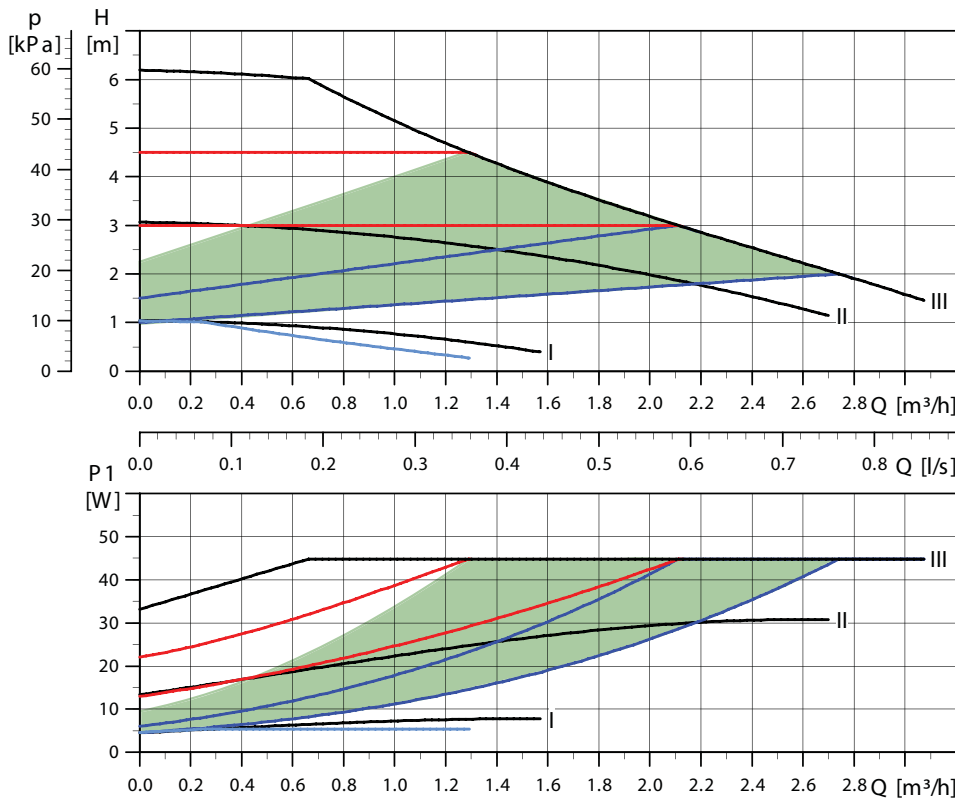

TM03 9085 3307 - TM03 0868 0705

Speed	P ₁ [W]	I _{1/1} [A]
Min.	5	0.05
Max.	45	0.38

Connections: See "Union and valve kits" on page 18.
 System pressure: Max. 10 bar.
 Liquid temperature: +2 °C to +110 °C (TF 110).

The pump incorporates overload protection.

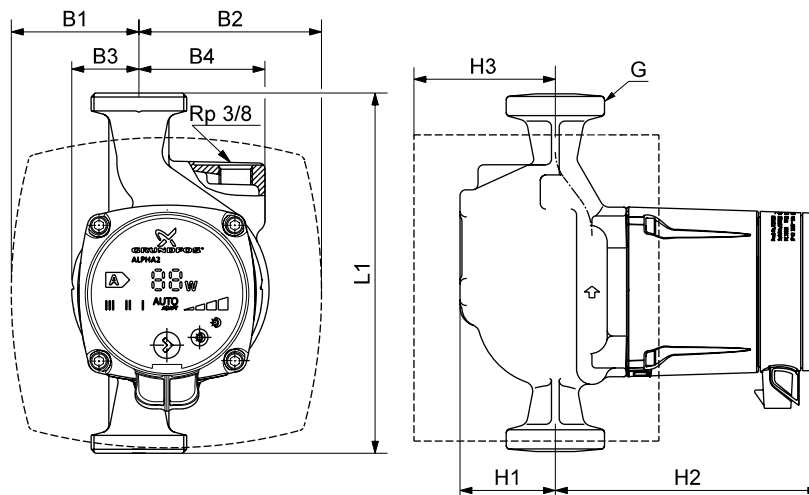

TM03 9211 3607

Pump type	Dimensions [mm]									Weights [kg]		Ship. vol. [m ³]
	L1	B1	B2	B3	B4	H1	H2	H3	G	Net	Gross	
ALPHA2 25-60 A	180	64	91	34	65	50	137	71	1 1/2	3.1	3.3	0.0063

Union and valve kits

Pump type	Description	Material	Product number
ALPHA2 25-40, 25-40 A, 25-50, 25-60, 25-60 A	3/4" unions	Cast iron	529921
	1" unions	Cast iron	529922
	3/4" valves	MS	519805
	1" valves	MS	519806
ALPHA2 25-40 N, 25-60 N	3/4" unions	MS	529971
	1" unions	MS	529972
	3/4" valves	MS	519805
ALPHA2 32-40, 32-60	1" unions	Cast iron	509921
	1 1/4" unions	Cast iron	509922

Insulation kits

GRUNDFOS ALPHA2 can be fitted with two insulating shells.

The insulation thickness of the insulating shells corresponds to the nominal diameter of the pump.

The insulation kit, which is tailored to the individual pump type, encloses the entire pump housing. The two shells are easily fitted around the pump.

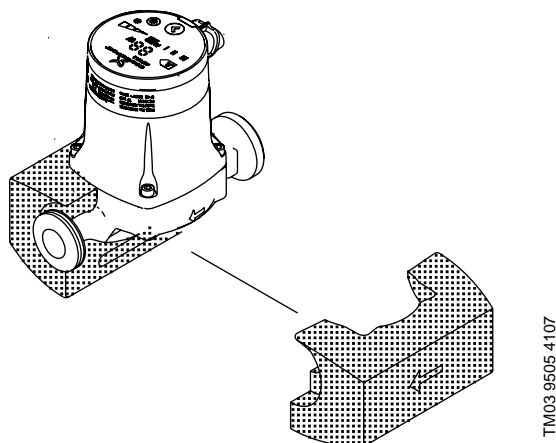
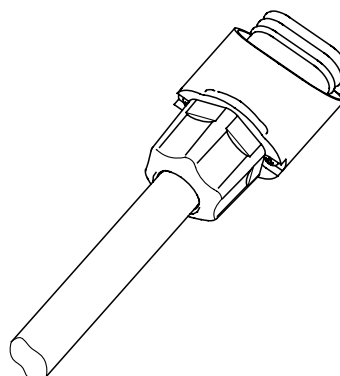

Fig. 18 Insulating shells

Pump type	Product number
ALPHA2 15-40, 25-40, 32-40, 25-50, 25-60, 32-60	505821
ALPHA2 25-40 A, 25-60 A	505822

Service kit



TM01 9911 3400

Fig. 19 Plug

Description	Product number
Plug	595562

WebCAPS

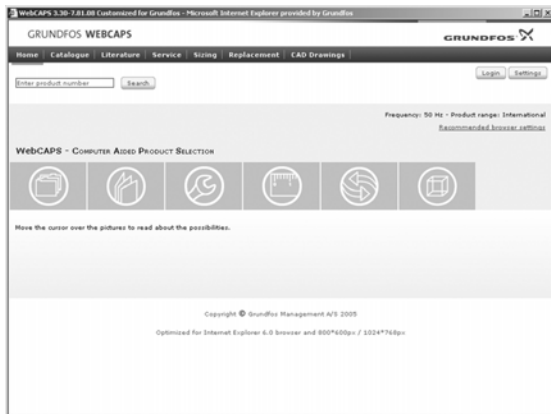

WebCAPS is a **Web-based Computer Aided Product Selection** program available on www.grundfos.com.

WebCAPS contains detailed information on more than 185,000 Grundfos products in more than 20 languages.

In WebCAPS, all information is divided into 6 sections:

- Catalogue
- Literature
- Service
- Sizing
- Replacement
- CAD drawings.

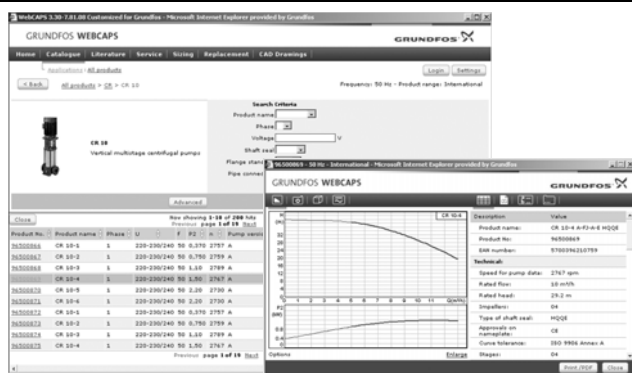

Catalogue

With a starting point in areas of applications and pump types, this section contains

- technical data
- curves (QH, Eta, P1, P2, etc) which can be adapted to the density and viscosity of the pumped liquid and show the number of pumps in operation
- product photos
- dimensional drawings
- wiring diagrams
- quotation texts, etc.

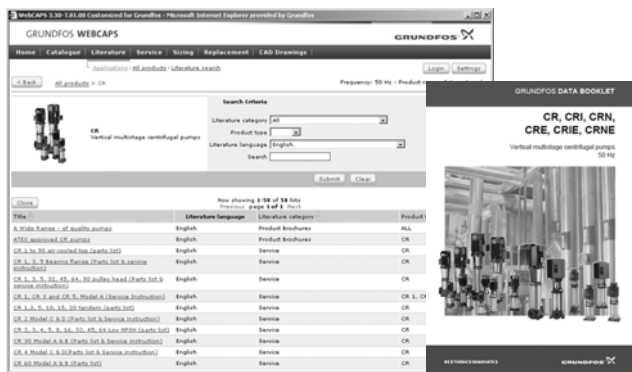

Literature

In this section you can access all the latest documents of a given pump, such as

- data booklets
- Installation and operating instructions
- service documentation, such as Service kit catalogue and Service kit instructions
- quick guides
- product brochures, etc.

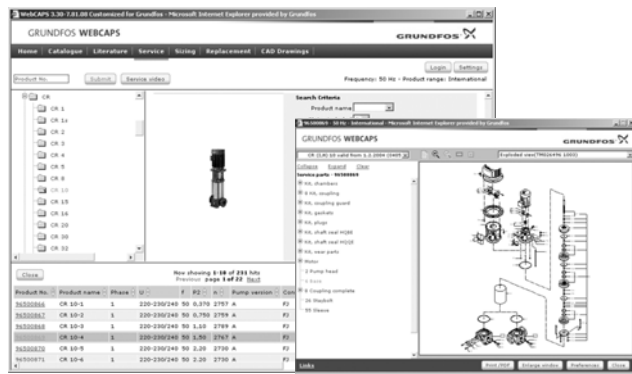

Service

This section contains an easy-to-use interactive service catalogue. Here you can find and identify service parts of both existing and cancelled Grundfos pumps. Furthermore, this section contains service videos showing you how to replace service parts.



Sizing

With a starting point in different application areas and installation examples, this section gives easy step-by-step instructions in how to

- select the most suitable and efficient pump for your installation
- carry out advanced calculations based on energy consumption, payback periods, load profiles, lifecycle costs, etc.
- analyse your selected pump via the built-in lifecycle cost tool
- determine the flow velocity in wastewater applications, etc.



Replacement

In this section you find a guide to select and compare replacement data of an installed pump in order to replace the pump with a more efficient Grundfos pump.

The section contains replacement data of a wide range of pumps produced by other manufacturers than Grundfos.

Based on an easy step-by-step guide, you can compare Grundfos pumps with the one you have installed on your site. After having specified the installed pump, the guide suggests a number of Grundfos pumps which can improve both comfort and efficiency.



CAD drawings

In this section it is possible to download 2-dimensional (2D) and 3-dimensional (3D) CAD drawings of most Grundfos pumps.

The following formats are available in WebCAPS:

2-dimensional drawings

- .dxf, wireframe drawings
- .dwg, wireframe drawings.

3-dimensional drawings

- .dwg, wireframe drawings (without surfaces)
- .stp, solid drawings (with surfaces)
- .eprt, E-drawings.



WinCAPS



Fig. 20 WinCAPS CD-ROM

WinCAPS is a **Windows-based Computer Aided Product Selection** program containing detailed information on more than 185,000 Grundfos products in more than 20 languages.

The program contains the same features and functions as WebCAPS, but is an ideal solution if no Internet connection is available.

WinCAPS is available on CD-ROM and updated once a year.

96769610 1107	GB

Subject to alterations.