

Glow-worm
The energy you need

High Efficiency Boilers & Accessories



**FREE
5 YEAR
WARRANTY***
on all Ultracom
and Flexicom
boilers

* Free Glow-worm 5 year warranty available on all Flexicom and Ultracom products, when claimed through Club Energy.
www.glow-wormclubenergy.co.uk
0845 2757018

welcome



Contents

This brochure has been developed to provide you with all the information you could ever want to know about the Glow-worm range of High Efficiency boilers, hot water cylinders, intelligent controls and accessories.

Either use the contents below to navigate straight to the exact information you are looking for, or sit down and have a good read of everything that we can do to create a perfect heating system for you, making your life warm and simple.

Contents	03
Why choose Glow-worm?	04 – 05
The Ultracom High Efficiency condensing boiler range	06 – 11
The Flexicom High Efficiency condensing boiler range	12 – 15
The Ultrapower sxi advanced system store range	16 – 19
Intelligent controls and timers	20 – 25
Hot water cylinders	26 – 27
Accessories: plume & condensate solutions	28 – 29
Renewable technologies	30 – 31
Glow-worm service	32 – 33
Market leading training	34 – 35
Club Energy	36 – 37
Technical data	38
The Ultracom range	38 – 41
The Flexicom range	42 – 45
The Ultrapower range	46
Hot water cylinders	47 – 48
Product dimensions & clearances	49 – 50
Flueing	51
Ø60/100mm Horizontal flueing options	51
Ø80/125mm Horizontal flueing options	51
Ø60/100mm Vertical flueing options	52
Ø80/125mm Vertical flueing options	52
Direct rear flueing options	53
Flueing accessories	53
Controls options	54 – 55



**FREE
5 YEAR
WARRANTY***
on all Ultracom
and Flexicom
boilers



Why choose Glow-worm?

Over 75 years of commitment to top quality, reliability and exceptional durability have made Glow-worm one of the UK's leading heating manufacturers. We have built our reputation on delivering products which are straightforward, dependable and designed with you in mind.

Today, Glow-worm not only produce award winning High Efficiency domestic boilers, but we also offer intelligent controls, hot water cylinders and a wide range of renewable technologies all boasting low energy consumption reducing both your costs and your carbon footprint.



Our product range has been designed to meet the needs of a wide range of UK homes. With straightforward, universal flueing systems, diagnostics, user controls and installation accessories, once you have installed or used any Glow-worm appliance, we hope you'll feel as confident about our products as we do.

As part of one of the world's largest heating manufacturing groups, we use our extensive skills and expertise to ensure each of our products are produced to the highest standards. Constant product development and innovative manufacturing practices create first class, quality products, which are constantly being re-affirmed by independent institute tests – so you don't just have to take our word for it.

Glow-worm are committed to working in partnership with a number of leading industry bodies.



As well as providing durable, reliable products, Glow-worm supports you from the beginning of your installation for years into the future. From award winning design, technical help, extensive training courses and specialist onsite support to a nationwide after sales and spares network, Glow-worm provide you with expert help and support whenever you need it.

* Free Glow-worm 5 year warranty available on all Flexicom and Ultracom products, when claimed through Club Energy. www.glow-wormclubenergy.co.uk 0845 2757018



The Ultracom range

High Efficiency condensing boilers providing every day family comfort and a choice of controls

The Ultracom range of high performance boilers

Busy families need a heating system which fully supports their lifestyle and provides perfect comfort levels. Featuring a stainless steel heat exchanger, the Ultracom range provides excellent heating and hot water comfort, and boasts low energy consumption; reducing both your costs and your carbon footprint.

Offering a variety of combi, storage combi, regular heat only or sealed system appliances in a wide range of outputs, the Ultracom range can cater for all heating requirements. A High Efficiency range with a NOx Class 5 rating (the best possible), the Ultracom range offers exceptional reliability and performance as well as complete flexibility with a wide range of control options.

The innovative production process of the complete Ultracom range is controlled and optimised through a seamless assembly monitoring system always ensuring the highest product quality standards.

Ultracom₂ cxi and sxi

Access all areas

Designed with hassle free installation in mind, the Ultracom₂ range of High Efficiency combi and system boilers offers a spacious internal design with easy access to all components without the need to remove the side panels meaning no side clearances are required.

Combined with straightforward one way wiring connections, a unique, simple filling loop design makes it very easy to repressurise the system. Installation and servicing are both straightforward and quick. The High Definition white backlit plain text display ensures hassle free and simple commissioning, whilst the advanced stainless steel heat exchanger and improved combustion technology reduce noise so much, you'll barely know the Ultracom₂ is there.

Flexible controls

With a choice of plug in analogue, digital or external intelligent controls the Ultracom₂ offers complete flexibility providing perfect home comfort for every application. Also featuring a unique receiver slot located inside the boiler, the Ultracom₂ and the Climapro₂ RF wireless programmable room thermostat are the perfect combination for advanced heating control.



* Free Glow-worm 5 year warranty available on all Flexicom and Ultracom products, when claimed through Club Energy. www.glow-wormclubenergy.co.uk 0845 2757018

Ultracom₂ 35 store

Glow-worm's High Efficiency storage combi

The Ultracom₂ 35 store is a fully integrated wall hung boiler, which combines the benefits of both a system and combi boiler in one package. It provides efficient heating and instant, unlimited domestic hot water, making it perfect for larger properties with a high domestic hot water demand.

The two 21 litre insulated tanks, housed inside the unit, provide a short re-heat time of less than 5 minutes and can significantly reduce heat loss.

Short regeneration time

One of the Ultracom₂ 35 store's major advantages is its short regeneration time. It requires less than 5 minutes to regenerate to its maximum capacity as compared to an alternative system boiler and cylinder, which may take over 30 minutes. As a result, you can always enjoy the comfort of hot water.

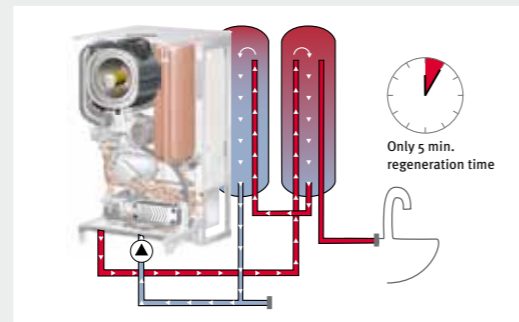
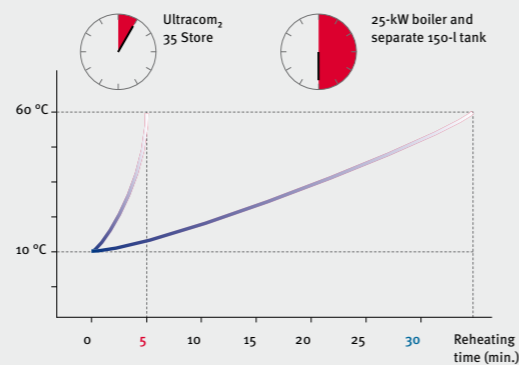

Two-tank principle

The Ultracom₂ 35 store contains two 21 litre tanks. The hot water in the first tank remains available for times when demand is greater. At times of high demand one or both of the tanks would provide additional hot water, which always comes from the top of the tank. This unique design can significantly reduce standing heat losses.

Ultracom hxi

Award winning High Efficiency range of easy to use Regular Heat Only boilers with an inbuilt digital programmer

The Ultracom range also features the 2010 Which? Best Buy Award winning Ultracom hxi regular heat only boiler range. To activate the digital programmer in a regular heat only system, simply install with the Options Board for on/off functionality, or the Smart Wiring Centre and a Glow-worm Climapro₂ RF for advanced control. All available as accessories.

This tried and tested boiler ticks all the boxes for performance and reliability, whilst providing a straightforward heating solution, and being simple to programme and use.



FREE 5 YEAR WARRANTY*
on all Ultracom and Flexicom boilers



FREE 5 YEAR WARRANTY*
on all Ultracom and Flexicom boilers



For detailed technical specification, see pages 38-41

* Free Glow-worm 5 year warranty available on all Flexicom and Ultracom products, when claimed through Club Energy. www.glow-wormclubenergy.co.uk 0845 2757018

Ultracom₂ cxi

High Efficiency combination boiler range with a choice of flexible control options

Models available

24, 30, 35kW

Key Features

- High Efficiency and NOx Class 5 rated
- Stainless steel heat exchanger ensures great performance and exceptional reliability
- 5 second hot water delivery (measured at tap 1m from the boiler)
- Simple in-built filling loop design ensures it is very easy to re-pressurise the system
- One way fit, simple wiring connections
- Easy access to all components from the front without the need to remove side panels meaning no side clearances are required
- Enhanced commissioning features - boiler self-check routine - initial pre-purge feature
- Clear fault code explanation - detailed plain text display helps use and commissioning
- Ultra quiet operation
- LPG compatible without separate conversion kit
- Flexible pre-fixing jig (optional accessory) - 1 jig for upward or downward piping
- Spacing frame available as an optional accessory
- Compatible with Glow-worm eBus controls including Climapro₂ RF
- Unique receiver slot inside the boiler for easy installation of the Climapro₂ RF
- Choice of plug in analogue or digital timer as optional accessory
- Compatible with Optiflue
- 2 years parts and labour warranty

Dimensions (mm)

740(h) x 418(w) x 346(d)

Maximum flue lengths

Ø60/100 mm Horizontal	10m
Ø60/100 mm Vertical	10m
Ø80/125 mm Horizontal	25m
Ø80/125 mm Vertical	25m

Ultracom₂ sxi

High Efficiency sealed system boiler range with a choice of flexible control options

Models available

12, 18, 30kW

Key Features

- High Efficiency and NOx Class 5 rated
- Stainless steel heat exchanger ensures great performance and exceptional reliability
- One way fit, simple wiring connections
- Easy access to all components from the front without the need to remove side panels meaning no side clearances are required
- Enhanced commissioning features - boiler self-check routine - initial pre-purge feature
- Clear fault code explanation - detailed plain text display helps use and commissioning
- Ultra quiet operation
- LPG compatible without separate conversion kit (18 & 30kW models)
- Flexible pre-fixing jig (optional accessory) - 1 jig for upward or downward piping
- Spacing frame available as an optional accessory
- Compatible with Glow-worm eBus controls including Climapro₂ RF and Smart Wiring Centre
- Unique receiver slot inside the boiler for easy installation of the Climapro₂ RF
- Plug in digital timer as an optional accessory
- 2 years parts and labour warranty

Dimensions (mm)

740(h) x 418(w) x 346(d)

Maximum flue lengths

Ø60/100 mm Horizontal	10m
Ø60/100 mm Vertical	10m
Ø80/125 mm Horizontal	25m (20m on Ultracom ₂ 12sxi)
Ø80/125 mm Vertical	25m (20m on Ultracom ₂ 12sxi)



Ultracom₂ 35 Store

High Efficiency storage combi

Models available

35kW

Key Features

- High Efficiency and NOx Class 5 rated
- Stainless steel heat exchanger ensures great performance and exceptional reliability
- Provides high performance heating and instant, sustained hot water supply for larger properties
- System contains two highly insulated 21 litre integrated tanks to provide constant and large hot water usage, and reduced heat loss
- Fast re-generation times of less than 5 minutes
- DHW flow rate of 19.7 litres/minute
- All components housed within a single compact wall hung unit, meaning minimal space is required in comparison to other comparable performance heating solutions
- Features 12 litre expansion vessel to cover larger system requirements
- One way fit, simple wiring connections
- Clear fault code explanation - detailed plain text display to help use and commissioning
- Ultra quiet operation
- Removable easy clean filter helps protect the heating circuit, even in hard water areas
- Compatible with Glow-worm's eBUS controls including Climapro₂ RF
- 2 years parts and labour warranty

Dimensions (mm)

890(h) x 470 (w) x 561 (d)

Maximum flue lengths

Ø60/100mm Horizontal	10m
Ø60/100mm Vertical	10m
Ø80/125mm Horizontal	12m
Ø80/125mm Vertical	13m

Ultracom hxi

Regular heat only boiler range with an inbuilt digital programmer

Models available

12, 15, 18, 24, 30 & 38kW

Key Features

- High Efficiency & NOx Class 5
- Stainless steel heat exchanger ensures great performance and exceptional reliability
- Advanced diagnostics
- Inbuilt frost protection
- LPG compatible without conversion kit
- Compatible with Glow-worm eBus controls including Climapro₂ RF
- Awarded the Which? Best Buy award 2008 and 2010
- 2 years parts and labour warranty

Dimensions (mm)

726(h) x 450(w) x 334(d)

Maximum flue lengths

Ø60/100 mm Horizontal	10m
Ø60/100 mm Vertical	10m
Ø80/125 mm Horizontal	25m
Ø80/125 mm Vertical	25m



* Free Glow-worm 5 year warranty available on all Flexicom and Ultracom products, when claimed through Club Energy. www.glow-wormclubenergy.co.uk 0845 2757018



The Flexicom range

High Efficiency condensing boiler;
cupboard fit with direct rear flue option

Compact and flexible

To replace an old boiler or install a new one with the minimum of fuss, you need one that will fit just about anywhere. That's why Glow-worm created the Flexicom - a High Efficiency condensing boiler that's so flexible, compact and simple to install it makes your life easy.

The Flexicom is compact enough to fit in a standard kitchen cupboard and was the first High Efficiency boiler in the UK with a direct rear flue, meaning that if you are looking to remove a standard efficiency boiler with a direct rear flue, the Flexicom will easily replace it.

Available as a combi, regular heat only or a sealed system boiler with a wide range of outputs, the Flexicom is recommended by the Energy Saving Trust with a NOx class 5 rating.

Robust and simple

The Flexicom provides a quick and simple installation with no need to remove the front casing during installation thanks to the pre-fixing jig, upward piping frame and the drop down connection block. The aluminium heat exchanger also has wide waterways which enable the Flexicom to easily cope with system debris that has built up over time - ideal for retrofit.



The perfect temperature at all times.

The optional glide down timer on the Flexicom cx. For full information on Glow-worm controls, please turn to page 54-55.



* Free Glow-worm 5 year warranty available on all Flexicom and Ultracom products, when claimed through Club Energy. www.glow-wormclubenergy.co.uk 0845 2757018



Flexicom hx

Cupboard fit High Efficiency regular heat only boiler with direct rear flue option

Models available

12, 15, 18, 24, 30, 35kW

Key Features

- High Efficiency & NOx Class 5
- Fits inside standard kitchen cupboard*
- Direct rear flue option
- Advanced diagnostics
- Inbuilt frost protection
- Compatible with Glow-worm eBus controls including the Climapro₂ RF
- 2 year parts & labour warranty

Dimensions (mm):

600(h) x 375(w) x 280(d)

Maximum flue lengths

Ø60/100 mm Horizontal	8m
Ø60/100 mm Vertical	8m
Ø80/125 mm Horizontal	20m
Ø80/125 mm Vertical	20m

Flexicom cx

Cupboard fit High Efficiency combination boiler with direct rear flue option

Models available

24, 30, 35kW

Key Features

- High Efficiency & NOx Class 5
- 5 second hot water delivery (measured at tap 1m from boiler)
- Fits inside standard kitchen cupboard*
- Direct rear flue option
- Advanced diagnostics
- Inbuilt frost protection
- Pre-fixing jig
- Optional upward piping kit
- Optional glide down timer
- Compatible with Glow-worm eBus controls including the Climapro₂ RF
- 2 year parts & labour warranty

Dimensions (mm):

700(h) x 390(w) x 280(d)

Maximum flue lengths

Ø60/100 mm Horizontal	8m
Ø60/100 mm Vertical	8m
Ø80/125 mm Horizontal	20m
Ø80/125 mm Vertical	20m



Flexicom sx

Cupboard fit High Efficiency sealed system boiler with direct rear flue option

Models available

18, 30kW

Key Features

- High Efficiency & NOx Class 5
- Fits inside standard kitchen cupboard*
- Direct rear flue option
- Advanced diagnostics
- Inbuilt frost protection
- Pre-fixing jig
- Compatible with Glow-worm eBus controls including the Climapro₂ RF
- Optional upward piping kit
- 2 year parts & labour warranty

Dimensions (mm):

700(h) x 390(w) x 280(d)

Maximum flue lengths

Ø60/100 mm Horizontal	8m
Ø60/100 mm Vertical	8m
Ø80/125 mm Horizontal	20m
Ø80/125 mm Vertical	20m

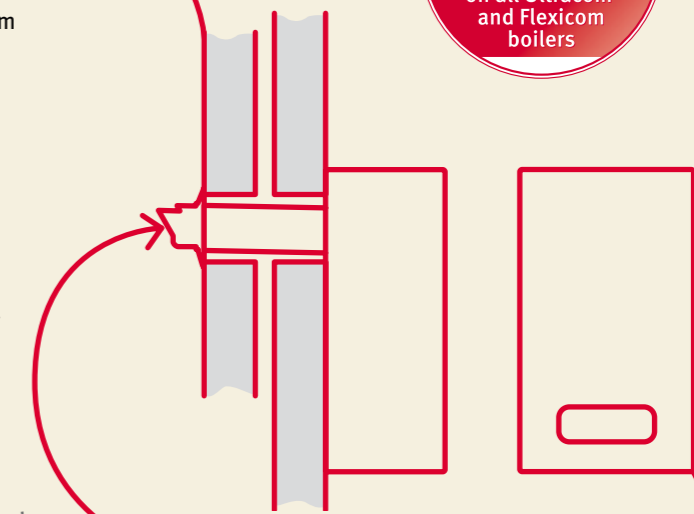

Available with optional direct rear flue.
The first High Efficiency boiler in the UK with an optional direct rear flue - perfect for replacements.

*Sizes of kitchen cupboards may vary. Please check boiler and cupboard dimensions prior to installations.

* Free Glow-worm 5 year warranty available on all Flexicom and Ultracom products, when claimed through Club Energy. www.glow-wormclubenergy.co.uk 0845 2757018



The Ultrapower sxi range

Advanced system store
Complete heating system in one box

Best of both

Some properties require a heating system which can keep up with even the busiest of families. Designed specifically for larger homes, Glow-worm's Ultrapower can provide both outstanding performance and significant energy savings in one floor standing appliance.

One of the most efficient boilers in the UK as rated by SEDBUK, the Ultrapower provides endless hot water on demand through an innovative storage system with fast reheat times and back-up from the inbuilt 31kW combi, all within a single appliance that fits inside an airing cupboard.

Endless hot water on demand

The innovative shift load storage system of the Ultrapower sxi generates hot water whenever a tap is turned on. By drawing on the internal storage system at the same time it can rapidly deliver the performance of a 170 litre cylinder.¹

The Ultrapower sxi also utilises a much smaller hot water cylinder than a conventional system boiler, because the boiler recharges the cylinder as the hot water is being drawn off. This means the Ultrapower sxi provides the same hot water performance as a much larger indirect cylinder.



Notes:

¹ 170 sxi model

Complete control at the touch of a button

In addition to the impressive hot water delivery the Ultrapower sxi has an inbuilt digital programmer. This provides 7 day single or two channel control for central heating and hot water ensuring exceptional flexibility.

Climapro₂ RF

For full information on Glow-worm controls, please turn to page 54-55



Ultrapower sxi

High Efficiency system store delivering endless heating and hot water.

Models available

100, 170

Key Features

- High Efficiency
- 5 second hot water delivery (measured at a tap 1m from the boiler)
- Advanced diagnostics
- NOx class 5
- Inbuilt frost protection
- LPG compatible
- Pre-fixing jig
- Drop down electrical connections
- Inbuilt programmer
- Back up immersion heater
- Compatible with Glow-worm eBus controls including the Climapro₂ RF
- 2 year parts & labour warranty

Ultrapower 100 sxi

Dimensions (mm):

1260(h) x 575(w) x 600(d)

Maximum flue lengths

Ø60/100 mm Horizontal 8m

Ø60/100 mm Vertical 8m

Ø80/125 mm Horizontal 25m

Ø80/125 mm Vertical 25m

Ultrapower 170 sxi

Dimensions (mm):

1520(h) x 575(w) x 334(d)

Maximum flue lengths

Ø60/100 mm Horizontal 8m

Ø60/100 mm Vertical 12m

Ø80/125 mm Horizontal 25m

Ø80/125 mm Vertical 25m



* Free Glow-worm 5 year warranty available on all Flexicom and Ultracom products, when claimed through Club Energy. www.glow-wormclubenergy.co.uk 0845 2757018



Quick reheat times

The Ultrapower sxi recharges the cylinder as hot water is being drawn off, resulting in much faster reheat times compared to that of a conventional indirect cylinder.

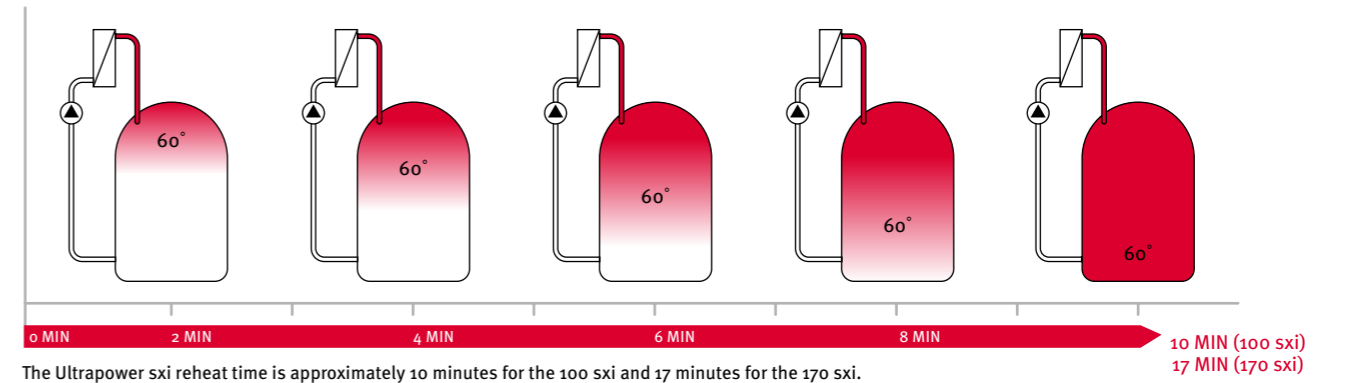

Hot water performance

The Ultrapower sxi heats the water stored in its cylinder directly, which makes it far more compact than an indirect cylinder.

Once the hot water store has been depleted, the boiler operates as a normal combi, which means you never run out of hot water.

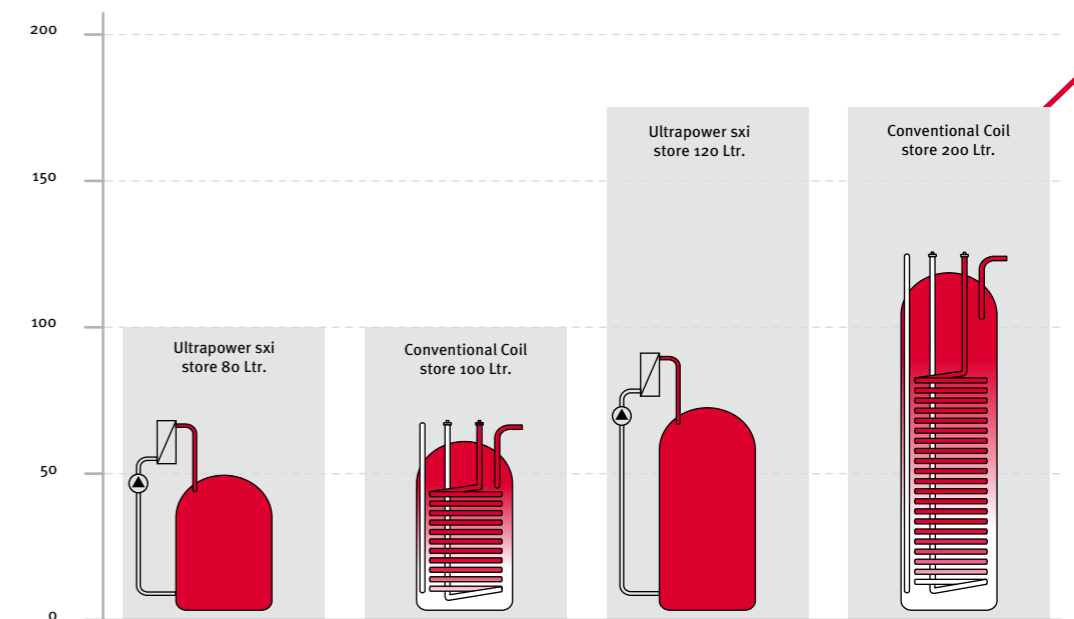

Controls and timers

Once you have taken the time to choose your new Glow-worm boiler, it soon becomes the reliable white box under the stairs, in the kitchen cupboard or in the airing cupboard. The central heating control however becomes part of your everyday life.

It is extremely important that you pair your new appliance with easy to use intelligent controls to get the most from your heating system.

Glow-worm provide a wide range of intelligent controls, all designed with user friendliness at their heart. With simple designs, push button controls and large screens which are easy to use, the Glow-worm range of controls provide the perfect solution for every home.

All Glow-worm controls use our intelligent eBus communication system to talk directly to your Glow-worm boiler, enabling continuous intelligent communication between the two appliances. This maximises the efficiency of the heating system, delivering savings on household energy bills.

comfort



Decreases your customers' energy use by 5%. Gives maximum comfort at minimum cost.

Control system designed for heating comfort and efficiency

The Glow-worm control system enables your customers to achieve exactly the temperature they demand in a straightforward way. Our controls use the latest technology making them even more efficient and much more user-friendly. Choosing the Climapro₁ with the automatic adaptive heating curve in combination with an outdoor sensor increases the system's efficiency by 5%* compared to traditional 230V controls. This gives your customer a system that's cost-efficient and kinder to the environment - and with the comfort level they want.

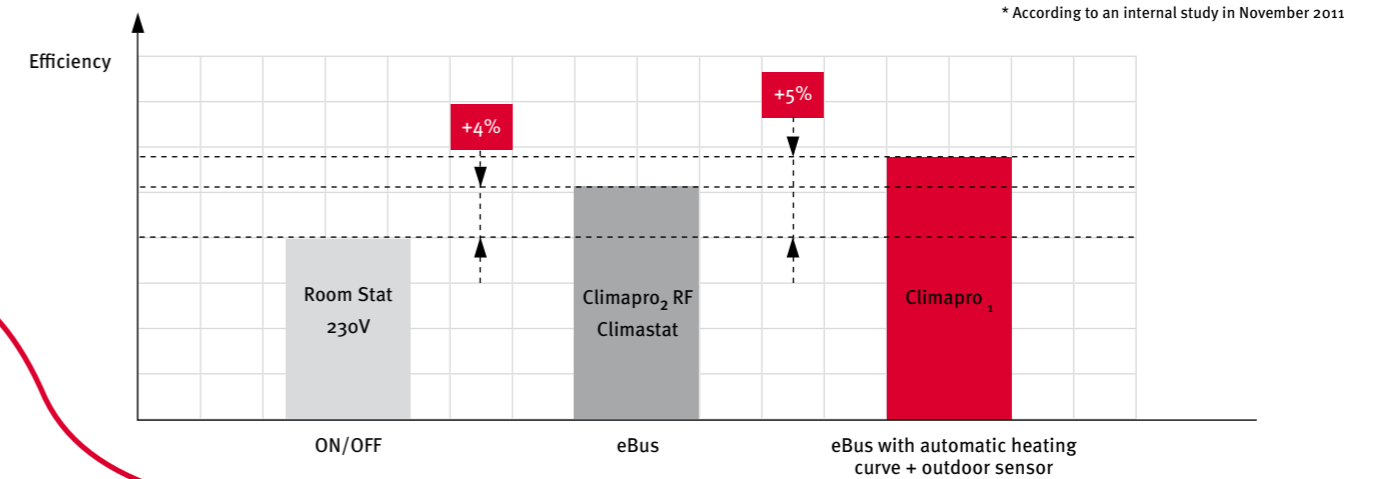

Intelligent room control explained

Intelligent room control is a method of controlling the flow temperature of water to the central heating system based on the temperature measured in the room.

As the temperature approaches the desired set point, the Glow-worm Climapro₂ begins to lower the flow temperature of water supplied to the central heating system (radiators).

A lower flow temperature means that the boiler can operate more efficiently and condense more. Energy costs are then reduced and a more stable and comfortable room temperature is achieved.

Weather compensation explained

Weather compensation works by measuring the temperature outside the property and adjusting the flow temperature from the boiler to the radiators accordingly, meeting the needs of the actual daily heat demands of the property. The colder the outdoor temperature, the hotter the flow temperature to the radiators, conversely as the weather improves and it becomes warmer outdoors, the cooler the flow temperature to the radiators. This ensures that the boiler is operating as efficiently as possible whilst still keeping the temperature in the house comfortable.



Clever eBus controls let end users decide the temperature in their home. A decision that pays off.

Our eBus controls give your customers all the benefits of 230V controls with added benefits. Their modulating system enables the set-up to communicate in a way that means the sophisticated appliance operates in a straightforward manner. By combining it with an outdoor sensor, the system recognises changes in the external temperature and adapts, which keeps your customer comfortable.

Modulating system

eBus controls talk intelligently to the appliance and directly adjust the flow temperature to the radiators. This increases your customer's comfort level as less time is needed to reach the set comfort temperature thanks to a lower boiler flow temperature. The room temperature is more stable, the system more efficient and appliance life is extended because of fewer on/off cycles.

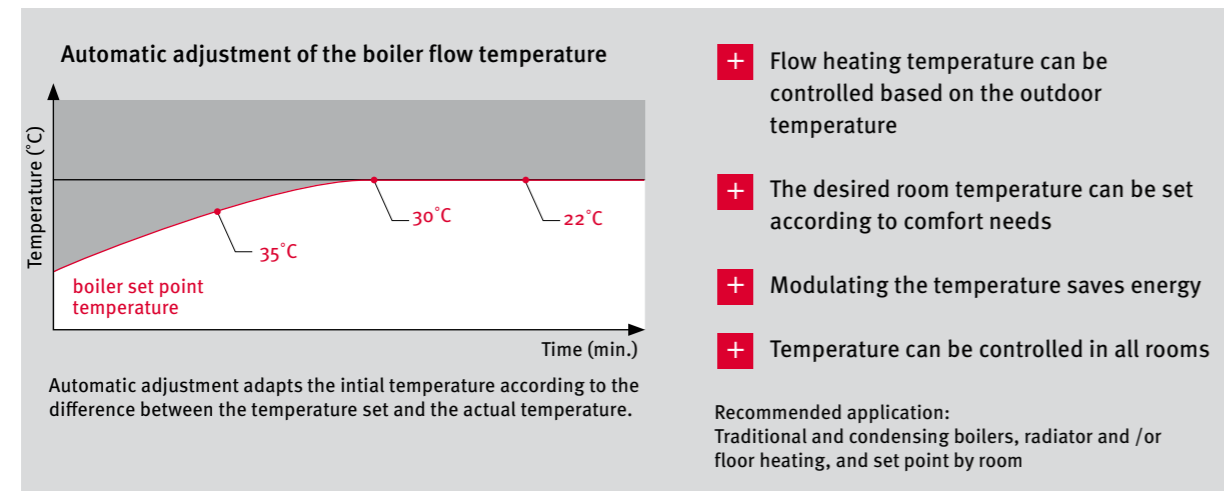

Room Thermostats

A room thermostat measures the room temperature and adapts it according to the desired home temperature. The product should be placed 1.5 m above the ground away from heat sources (fireplaces, radiators, TV, etc.) and shouldn't be exposed to direct sunlight or a draught. We offer a range of thermostats, from basic 230V room thermostats to more sophisticated intelligent programmable room thermostats.

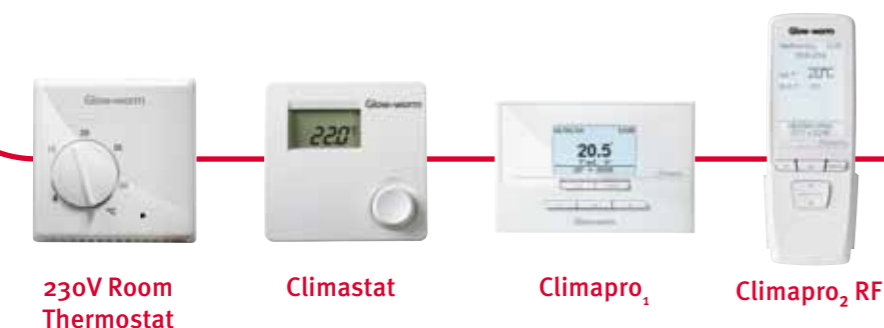

Outdoor sensor

Complementing the system with an outdoor sensor lets the system control the heating according to the temperature outside. This system element enables a drop or rise in the temperature to be compensated for, and, therefore, the boiler's flow temperature to be adjusted. End users benefit from a consistently high level of comfort because if the external temperature decreases quickly, the outdoor sensor enables the system to react to this just as rapidly. If the temperature sees a fast increase, the system also adjusts to keep the level of comfort as defined by the end user.

A Example of a rapid fall in temperature

B The outdoor sensor reacts very quickly and adapts the heating flow temperature accordingly

1 With an outdoor sensor, the system reacts immediately when the external temperature decreases

2 Without an outdoor sensor, the system is waiting for a decrease in the indoor temperature before it adapts the temperature

C The sensor reacts and the system adjusts accordingly so the level of comfort stays the same. With an outdoor sensor, the indoor temperature would decrease before it reaches the comfort temperature again.

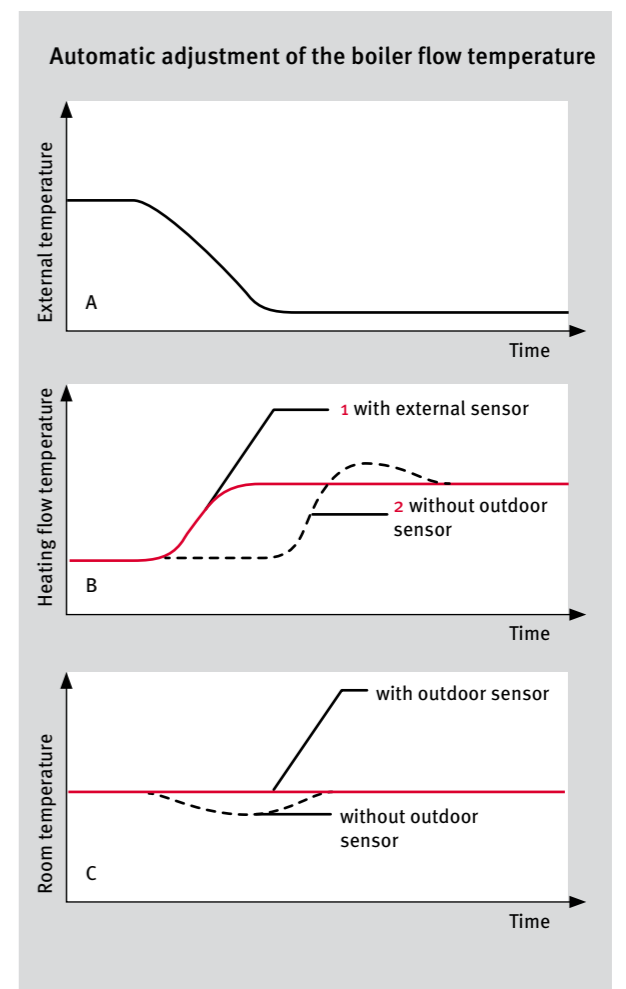

Outdoor sensors

An outdoor sensor measures the outdoor temperature and prepares the heating system for temperature changes so that the boiler can react before the room starts to cool down or heat up. When combined with a room thermostat that senses passive heat sources, an outdoor sensor provides your customer with a heating system that keeps them comfortable at all times.



Keeping the comfort level constant. Proven technology you can rely on.

We're constantly working on improving our products whilst taking customers' needs into account, and a control in the range has a new feature that ensures the room temperature doesn't deviate. The automatic adaptive heating curve is exclusive to the Climapro₁ control, when used with an outdoor sensor, and makes it stand out because no other boiler manufacturer's controls have this. The system establishes the most efficient setting to reach the level of comfort required, which is achieved based on the room temperature and time taken to reach the set temperature. The result is constant, simple and efficient comfort for your customers, with advanced technology behind it.

If the heat curve is set too high, the flow temperature will also be too high, meaning the appliance will be operating outside the optimum temperature for condensing. If the heat curve is set too low, the comfort level may never be reached. However, if the temperature is just right, the automatic heating curve function ensures this value remains constant, which achieves optimum efficiency and comfort. The technology is easy to set up and it aims to achieve a lower temperature, which then improves the condensation effect in the boiler. The result is a more efficient system overall, giving the system's efficiency level a welcome boost that can really be felt in the home.

Controls compatibility

The table below summarises the compatibility of the Glow-worm boiler range with our range of intelligent controls. For more detailed control option information turn to pages 54 to 55.

	Boiler	Boiler controls				Intelligent controls			Weather sensors		System integration	
		Glide down timer	Plug-in digital timer	230V room thermostat	Anologue timer	Climastat	Climapro ₁	Climapro ₂ RF	Outdoor sensor (wired)	Outdoor sensor (wireless)	Smart Wiring Centre ₂	Systempro
Combi's	Ultracom ₂ cxi	✗	✓	✓	✓	✓	✓	✓	✓	✓	✗	✓
	Flexicom cx	✓	✗	✓	✗	✓	✓	✓	✓	✓	✗	✓
	Betacom ₂ Easicom Ultimate	✗	✗	✓	✓	✓	✓	✓	✓	✓	✗	✗
System	Ultracom ₂ sxi	✗	✓	✓	✗	✓	✓	✓	✓	✓	✓	✓
	Flexicom sx	✗	✗	✓	✗	✓	✓	✓	✓	✓	✓	✓
Heat only	Ultracom hxi	✗	✗	✓	✗	✓	✓	✓	✓	✓	✓	✗
	Flexicom hx	✗	✗	✓	✗	✓	✓	✓	✓	✓	✓	✓
Stores	Ultracom ₂ 35 Store	✗	✗	✗	✗	✗	✓	✓	✓	✓	✗	✓
	Ultrapower	✗	✗	✓	✗	✓	✓	✓	✓	✓	✗	✗

Climapro₂ RF

Our innovative wireless programmable room thermostat for advanced heating and hot water control any time of the week.

Key Features

- Two channel wireless programmable room thermostat with time and temperature control of central heating and hot water
- Backlit display provides advanced user control and functionality
- Simple to use handheld unit can be wall mounted or portable within the living area
- Unique easy to install RF receiver which can be fitted inside the Ultracom₂ cxi and sxi models
- Capable of room and weather compensation (with outdoor sensor)

Climapro₁

Programmable room thermostat (Time and temperature)

Key Features

- Simple two channel controller for central heating and hot water
- Provides 24 hour or 7 day timed programme options
- Annual service reminder function
- Automatic update for summer/winter
- Simple & discreet 2 wire connection
- Automatic heat curve adjustment (when used with outdoor sensor)

Climastat

Thermostat (Temperature only)

Key Features

- Easy to use
- Extra low voltage
- Simple & discreet 2 wire connection
- Polarity not important

230V Room Thermostat

Room temperature

Key Features

- Easy to use
- Simple analogue control of room temperature
- Compatible with all Glow-worm boilers with the exception of Ultracom₂ 35 store

Systempro

This innovative controller is a weather compensated wiring centre which will accommodate up to three heating zones and one DHW zone.

Key Features

- System management suitable for boiler, cylinder, heat pump and hybrid systems
- Uses advanced technology to coordinate entire system
- Will control up to three heating zones and one domestic hot water zone
- Can be used with Climapro₂ RF, new wired Climapro₁ and Climapro₃ RF controls
- New 24V input to allow integration with OEM under floor heating
- Acts as a central installer interface where maintenance menus, fault history, system parameters, etc. can be accessed
- Use of outdoor sensor is mandatory

Smart Wiring Centre₂

Intelligent wiring centre

Key Features

- Allows Glow-worm intelligent controls to be used with Ultracom and Flexicom heat only and system appliances
- Can control up to two heating zones and one domestic hot water zone
- Simple colour coded connectors for easy wiring and installation*

* must be used with wired Climapro₁ on second heating zone

Wireless Outdoor Sensor

Wireless weather compensation sensor using inbuilt PV cells

Key Features

- Enables weather compensation when paired with Climapro₂ RF & Climapro₁ RF
- Works on indirect sunlight which re-charges the small PV cells
- Simple and quick to install
- No batteries required

Outdoor Sensor

Weather compensation sensor (Wired)

Key Features

- Enables weather compensation
- Wired sensor
- Simple and discreet
- Room temperature



Stainless steel, Unvented storage hot water cylinders

Hydracyl cylinders – for traditional heating systems

An integral part of any regular heat only or sealed system; Glow-worm's hot water cylinders are extremely reliable, hard wearing and come complete with a 25 year warranty against perforation of the stainless steel shell.

They are available in six sizes - 150, 205, 250 and 300 litres and manufactured from high grade stainless steel with laser welded seams.

Our cylinders are built with efficiency and performance in mind, and incorporate excellent insulation that achieves heat loss as low as 1.61kWh/24hrs¹ and a high recovery heating coil that reheats the cylinder in as little as 19 minutes.

Flurocyl₂ cylinders – for renewable heating systems

Glow-worm's Flurocyl₂ cylinder has one coil which heats water using power from your boiler and a second coil which heats water using energy from a solar panel. Whether you are installing a solar system now or simply preparing for the future, Glow-worm Flurocyl₂ cylinders are fully compatible with any regular heat only or sealed system boiler and fit easily through any standard airing cupboard door.

Special construction of the coils inside the cylinder ensures that the top two thirds of the cylinder is heated first enabling high volumes of hot water to be delivered on demand, and the thermostatic mixing valve mixes cold water into the solar heated water to achieve the required temperature for safe water usage.

Key Features

- Hydracyl available in 150, 205, 250 & 300 litre models
- Flurocyl₂ available in 200, 250 & 300 litre models
- High grade stainless steel cylinder with laser welded seams
- Maximum performance with minimum fuel costs.
- Insulation exceeds CHeSS Best Practice
- External expansion vessel supplied
- Complies with WRAS and G3 regulations
- Simple controls and wiring box
- Intelligent system solutions when used with Glow-worm appliances and eBUS controls
- Glow-worm 2 year warranty
- 25 Year Warranty on cylinder shell. (Subject to water quality, correct installation and annual servicing).

Notes:

- ¹ Attainable with 150l single coil model

Accessories: Plume & condensate solutions

Fully compatible with all Glow-worm boilers, these handy accessories help solve plumbing and condensate issues that can be faced when installing modern condensing boilers.

Plume Management Kit

This clever accessory exhausts plume further away from the duct, reducing the visual impact of the vapour trail.

The simple piping kit fits neatly onto the horizontal flue and can be extended to a maximum of 6m in length, fitting easily round ledges and other obstacles to achieve minimum clearance levels required on installations.



Plume Deflector Kit

A useful accessory takes the hassle out of flue gas termination by diverting plume left, right or upwards away from problem zones such as adjacent properties or walk ways.

Available in black or white, the Plume Deflector Kit can be installed quickly and simply onto a horizontal flue instead of the standard terminal end piece during or after installation.



Condensate Pump

To solve problems associated in locating a suitable outlet to drain away condensate from the condensing boiler, the Glow-worm Condensate Pump collects the condensate from the boiler and pumps it into the waste system.

The smallest available in the UK, the Glow-worm Condensate Pump operates at maximum efficiency with the reservoir pump discharging the condensate in one go when the fill level is reached, rather than as a continuous operation.



The **NEW** Optiflue

Optiflue Passive Flue Gas Heat Recovery is compatible with the Ultracom₂ cxi combination boiler range. This latest innovation from Glow-worm provides increased boiler efficiency by capturing waste energy from the flue gases and using this energy to pre-heat the incoming mains water supply. Effectively the boiler will use less gas to heat the hot water to the required temperature.

The Optiflue unit is easily fitted to the boiler and can be used in both vertical installations with the standard flue kit or in horizontal installations using the new horizontal flue kit (00200165257).

Optiflue can reduce running costs for the homeowner and can help meet the requirements of higher levels of the code for sustainable homes - on new dwellings the energy rating can be increased by circa +3%.



Ridge Tile Terminal

The Ridge Tile Terminal accessory is designed to make the roof finish look neater and less obtrusive. Available in a black enamel finish, the ridge tile accessory can be fitted to purpose designed flue outlet ridge tiles and provides a quick and easy design solution.



Take the step into Renewable technologies

There are lots of different types of renewable energy solutions to choose from in the UK – solar thermal, air source heat pumps, ground source heat pumps, biomass, micro CHP, solar photovoltaics (PV). The list is growing on an almost daily basis as new technologies are developed. All have different strengths, capital costs, payback periods and carbon savings.

Glow-worm can help you navigate through all these different choices and create a renewables solution that meets your needs whether you are interested in the technology because you want to reduce your own carbon emissions or you are meeting stringent government legislation.



Practical and straightforward solutions

Building on our knowledge of UK heating systems and our worldwide experience of renewables technologies as part of one of the world's largest heating manufacturing groups, we specialise in the most practical and straightforward solutions that are suited to the average UK house:

- Clearly Solar - Solar thermal
- Clearly Heat Pumps - Air to water heat pumps
- Clearly Heat Recovery - Mechanical ventilation with heat recovery
- Clearly Hybrid - The UK's first dual source heating system

All supported from beginning to end by Glow-worm's experienced pre and after sales services, including advanced project support, award winning design service, training, assisted commissioning and expert after sales support. Glow-worm assists you to make the right choices and support you in this new world of heating and hot water technologies.



Expert support from start to finish

As well as providing durable, reliable products, Glow-worm supports you from the beginning of your installation for years into the future. From design, technical help, extensive training courses and specialist onsite support to a nationwide after sales and spares network, Glow-worm provide you with expert help and support whenever you need it.



Top-class service

Technical help

If you are planning or even in the middle of an installation and have a technical question you need answering, simply call our technical help line for a straightforward answer.

System design

Glow-worm's award winning Design Service is a complete service tailored to suit your individual site requirements. From basic heating designs to more complex solutions using the latest renewables technologies, Glow-worm design uses state of the art CAD technology to provide high quality designs supported by full indemnity cover.

Full local support

Our nationwide sales team provide installers and specifiers with support and partnership from beginning to end.

Nationwide after sales service

We are committed to supporting you with technical help and after sales service online, over the telephone and on the road.

All our service engineers are Gas Safe registered and are fully trained on all Glow-worm's models past and present. We have around 250 engineers based across the UK, each carrying over 1,500 different spare parts in their van enabling them to achieve an outstanding 97% first time fix rate.

Product warranty

All Glow-worm products are designed to exacting industry standards, and are individually tested to ensure reliability. All Ultracom, Flexicom and Ultrapower boilers come with 2 years parts and labour warranty as standard with extended warranty options available. Free 5 year warranty available when claimed through Club Energy.

Spares

If in the unlikely event a problem occurs and a spare part is needed, then you can rest assured that Glow-worm's market leading spare parts division will have the item you require. Thanks to our commitment towards maintaining functional spare parts, availability is for up to 15 years after the range production ends.

Glow-worm has a nationwide network of over 30 key spares stockists at approximately 450 locations around the UK which means getting hold of a genuine Glow-worm spare part is as convenient as possible. If for any reason the items are not held by the stockist, Glow-worm offers a next day delivery service for emergency orders.

Online information

If you want standard technical advice information such as installation manuals and flueing information and don't want to spend time on the telephone, visit our website at www.glow-worm.co.uk where you will find comprehensive technical information, solutions to common installation system problems and advice on saving energy.

Always within reach, always there for you

Head Office:
01773 824639

Literature:
01773 596105

After Sales Service:
Boilers
01773 828100
Renewables
01773 596150

Technical Support & Advice:
Boilers
01773 828300
Renewables
08447 361143

Glow-worm design:
0116 2392393

Spare Parts:
01773 596090

service

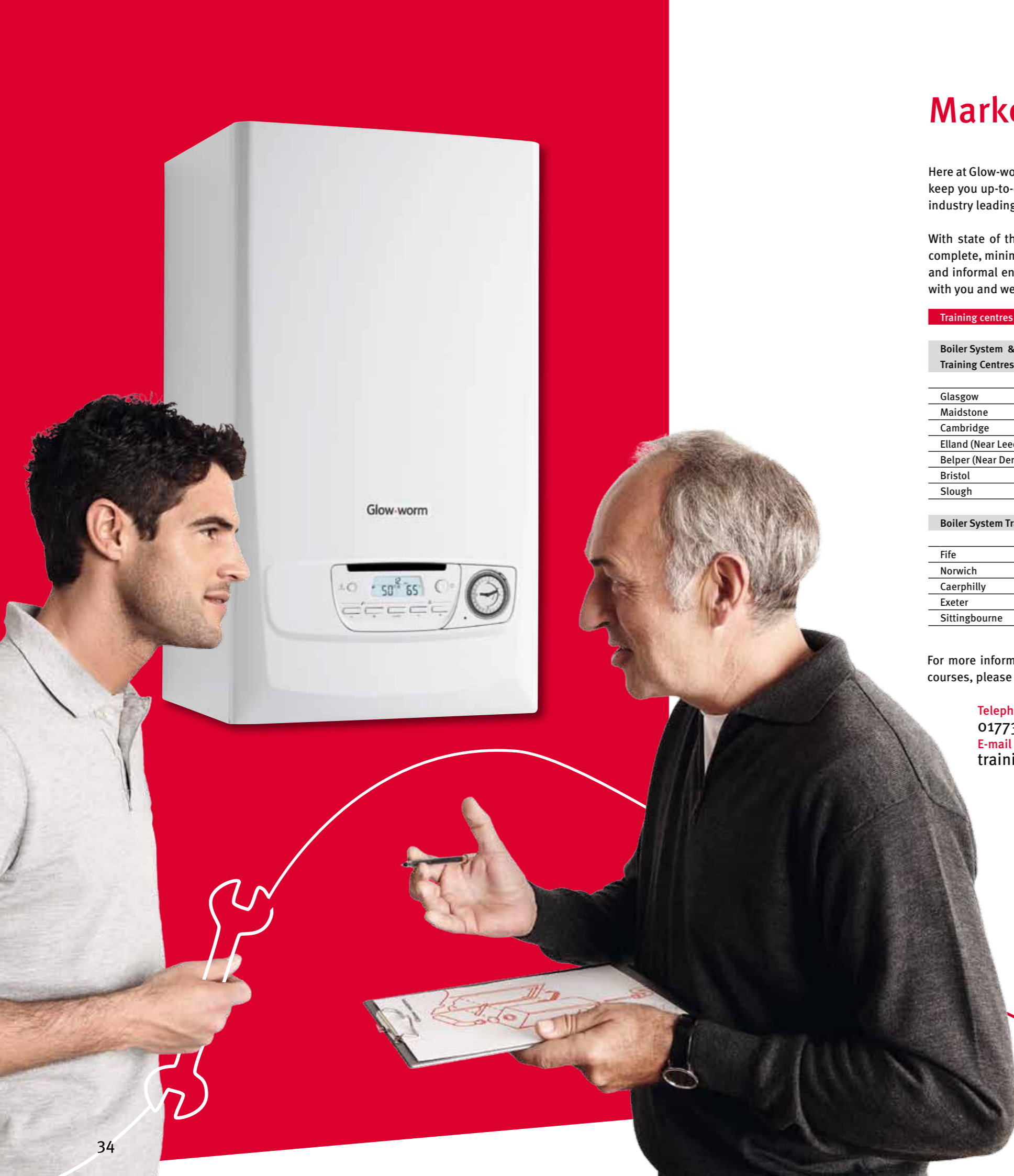

Market leading training

Here at Glow-worm, we believe that knowledge is key to a successful business. This is why we offer a range of courses to keep you up-to-date with new technologies and industry regulations. Each year Glow-worm provides straightforward, industry leading no-nonsense training for thousands of professionals.

With state of the art training facilities located throughout the UK and each course only taking one or two days to complete, minimum time is taken away from the job. Our training is delivered by fully qualified practitioners in a relaxed and informal environment supported fully by reference materials and technical data sheets which you will take away with you and we won't let you go hungry as lunch and all refreshments are provided.

Training centres

Boiler System & Renewables Training Centres

Glasgow
Maidstone
Cambridge
Elland (Near Leeds)
Belper (Near Derby)
Bristol
Slough

Boiler System Training Centres

Fife
Norwich
Caerphilly
Exeter
Sittingbourne

For more information on Glow-worm training courses, please contact:

Telephone

01773 596156

E-mail

training@glow-worm.co.uk

Ultracom₂ product range training

1 day £40.00 per person inc VAT

Full training on the Glow-worm Ultracom range of High Efficiency condensing boilers including the Ultracom₂ cxi and sxi, Ultracom₂ 35 store and the Ultracom hxi ranges.

Flexicom product range training

1 day £40.00 per person inc VAT

Full training on the Glow-worm Flexicom range of High Efficiency condensing boilers.

Energy Efficiency for Domestic Heating

1 day £141.00 per person inc VAT

Up-to-date information and training on technical system design, installation and regulations. Certificate in Energy Efficiency for Domestic Heating awarded on completion.

G3 unvented cylinder training

1 day £158.60 per person inc VAT

G3 is a mandatory qualification that you must hold when installing unvented cylinders. At the end of this 1 day course you will be fully qualified to work with unvented cylinders. A G3 unvented qualification must be held before taking a BPEC course.

Clearly Solar product training

1 day £40.00 per person inc VAT

Full training on the Glow-worm Clearly Solar range, including insight into general solar thermal theory.

Solar BPEC course

2 day £411.25 per person inc VAT

Intensive hands on course providing in-depth training on all domestic solar thermal systems including roof work. The course is certified through an examination at the end of the two days, providing successful candidates with a BPEC solar accreditation which is required to gain MCS approval.

Clearly Heat Pumps product training

1 day £40.00 per person inc VAT

Full training on the Glow-worm Clearly Heat Pumps range, including insight into general heat pumps theory.

Clearly Heat Recovery product training

1 day £40.00 per person inc VAT

Full training on the Glow-worm Clearly Heat Recovery range, including insight into general mechanical ventilation with heat recovery theory.

A rewarding partnership

clubenergy

Glow-worm believes in developing partnerships with our loyal installers to ensure that their business will grow with ours.

By choosing Glow-worm you not only have access to one of the UK's leading ranges of performance heating solutions, but you also enter into an ongoing partnership with us that can prove extremely rewarding for you and your business.

We are delighted to introduce Club Energy, our installer loyalty programme designed to support your business growth with an extensive range of exclusive member benefits to ensure you can professionally grow your business and make your working life easier.

Through our dedicated Club Energy website you will have access to new customer leads and an array of free business development tools to enable you to create your own websites and adverts, use our easy quote tool, sign up for free training and much, much more.

To join Club Energy just log on to

www.glow-wormclubenergy.co.uk

or call

0845 275 7018



What's in it for you

Club Energy has one of the best ranges of member benefits you will find. Some of the highlights are:

Grow your business

- New customer leads direct from homeowners looking for Glow-worm installers
- Free training on our range of boilers and renewable products
- Priority technical hotline provides Glow-worm expertise with you on every job, whenever you need us
- Business development tools designed to maximise your marketing and make your life easier
- **Your own business website**
- **Professional advert and flyer designs**
- **Professional quote generation and service reminder tool**
- Exclusive offers on Glow-worm products and other branded tools

Everyday rewards

- Rewards for every single Ultracom or Flexicom boiler you claim
- Rewards for all Glow-worm renewable products such as Clearly Solar, Clearly Heat Pumps, Clearly Hybrid and Clearly Heat Recovery as well as our range of Cylinders and our Climapro₂ RF control.
- A range of exclusive branded merchandise
- All rewards are redeemable for any voucher in our extensive range of online and high street retailers

All you need to know - first!

- Latest Glow-worm news including exclusive Glow-worm technical bulletins
- Industry news and legislative changes
- Quarterly Club Energy newsletter

Members benefits!

- **Free 5 Year Warranty on all Ultracom₂ and Flexicom boilers**
- VIP trips to our headquarters to see our facilities and meet the Glow-worm team
- Luxury UK and foreign breaks

Plumbing Toolbox App.

- Instant warranty and product reward registration
- Customer sales leads direct to your phone
- Fault finder at your fingertips
- Manuals and consumer brochures
- Book training
- Technical Support
- Gadgets...and much more!

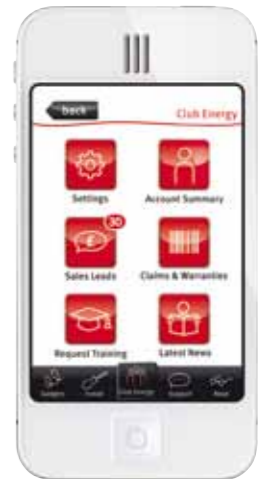

Note: some benefits are only available once various claiming levels have been reached

Interested in being a member?

If you would like to be a part of one of the heating industry's premier loyalty programmes, just speak to your local Glow-worm Team Energy Representative or contact us directly:

**Club Energy Hotline:
0845 275 7018**

Club Energy email address:
enquiries@glow-wormclubenergy.co.uk



The Ultracom₂ cxi range

Ultracom₂ cxi specifications - Combi

Ultracom ₂	24cxi	30cxi	35cxi
Size			
Casing dimensions (h w d) (mm)	740 x 418 x 346	740 x 418 x 346	740 x 418 x 346
Weight (lift) (kg)	37.1	37.7	38.3
Performance			
CH output (kW) Min/Max	4.9/18.2	5.9/24.6	8.4/30
DHW output (kW)	25.5	30.6	35.7
DHW flow rate (l/min, 35°C rise)	10.4	12.5	14.6
DHW response ¹	5 seconds	5 seconds	5 seconds
SEDBUK SAP 2009 rating (%)	89.0	89.3	89.3
SEDBUK SAP 2005 rating (%)	90.3	90.3	90.4
NOx class 5 (natural gas)	Yes	Yes	Yes
Adjustable to LPG	Yes	Yes	Yes
Construction			
Main heat exchanger type	Coiled tube	Coiled tube	Coiled tube
Heat exchanger material	Stainless steel isothermic	Stainless steel isothermic	Stainless steel isothermic
Burner type	Pre-mixed	Pre-mixed	Pre-mixed
Fully modulating	Yes	Yes	Yes
DHW plate heat exchanger	Yes	Yes	Yes
Integrated hydrobloc	Yes	Yes	Yes
Installation			
Suitable for sealed systems	Yes	Yes	Yes
Suitable for open-vent systems	No	No	No
Filling loop	Inbuilt	Inbuilt	Inbuilt
Flow restrictor	Yes 8l/min	Yes 10l/min	Yes 12l/min
Inbuilt system bypass	Yes	Yes	Yes
Inbuilt condensate trap/siphon	Yes	Yes	Yes
Inbuilt frost protection	2 stage	2 stage	2 stage
Zero compartment ventilation	Yes	Yes	Yes
Clearances			
Top (mm)	150	150	150
Side (mm)	0	0	0
Bottom (mm)	200	200	200
Front (mm) ²	600	600	600
User Interface			
User display	Digital/plain text	Digital/plain text	Digital/plain text
Diagnostics	Advanced/Intuitive	Advanced/intuitive	Advanced/intuitive
User adjustable CH temp control	Yes	Yes	Yes
User adjustable DHW temp control	Yes	Yes	Yes
'Eco' setting on DHW	Yes	Yes	Yes
Optional plug in digital timer kit	Yes	Yes	Yes
Optional plug in analogue timer kit	Yes	Yes	Yes
Pipes			
Optional pre-fixing jig ³	Yes	Yes	Yes
Optional spacing frame	Yes	Yes	Yes
Water connections	2 x 22mm, 2 x 15mm	2 x 22mm, 2 x 15mm	2 x 22mm, 2 x 15mm
Flues			
Max horizontal Ø60/100	10m	10m	10m
Max vertical Ø60/100	10m	10m	10m
Max horizontal Ø80/125	25m	25m	25m
Max Vertical Ø80/125	25m	25m	25m
Optional plume management kit Ø60/100	Yes	Yes	Yes



The Ultracom₂ sxi range

Ultracom₂ sxi specifications - Sealed System

Ultracom ₂	12sxi	18sxi	30sxi
Size			
Casing dimensions (h w d) (mm)	740 x 418 x 346	740 x 418 x 346	740 x 418 x 346
Weight (lift) (kg)	37.1	37.1	38.3
Performance			
CH output (kW) Min/Max	3.9/12	4.9/18.2	8.5/30
DHW output (kW)	N/A	N/A	N/A
DHW flow rate (l/min, 35°C rise)	N/A	N/A	N/A
DHW response ¹	N/A	N/A	N/A
SEDBUK SAP 2009 rating (%)	89.5	89.1	89.4
SEDBUK SAP 2005 rating (%)	90.4	90.4	90.5
NOx class 5 (natural gas)	Yes	Yes	Yes
Adjustable to LPG	No	Yes	Yes
Construction			
Main heat exchanger type	Coiled tube	Coiled tube	Coiled tube
Heat exchanger material	Stainless steel isothermic	Stainless steel isothermic	Stainless steel isothermic
Burner type	Pre-mixed	Pre-mixed	Pre-mixed
Fully modulating	Yes	Yes	Yes
DHW plate heat exchanger	N/A	N/A	N/A
Integrated hydrobloc	Yes	Yes	Yes
Installation			
Suitable for sealed systems	Yes	Yes	Yes
Suitable for open-vent systems	No	No	No
Filling loop	N/A	N/A	N/A
Flow restrictor	N/A	N/A	N/A
Inbuilt system bypass	Yes	Yes	Yes
Inbuilt condensate trap/siphon	Yes	Yes	Yes
Inbuilt frost protection	2 stage	2 stage	2 stage
Zero compartment ventilation	Yes	Yes	Yes
Clearances			
Top (mm) (from top of boiler)	150	150	150
Side (mm)	0	0	0
Bottom (mm)	200	200	200
Front (mm) ²	600	600	600
User Interface			
User display	Digital/plain text	Digital/plain text	Digital/plain text
Diagnostics	Advanced/intuitive	Advanced/intuitive	Advanced/intuitive
User adjustable CH temp control	Yes	Yes	Yes
User adjustable DHW temp control	Yes ²	Yes ²	Yes ²
'Eco' setting on DHW	N/A	N/A	N/A
Optional plug in digital timer kit	Yes	Yes	Yes
Optional plug in analogue timer kit	No	No	No
Pipes			
Optional pre-fixing jig ³	Yes	Yes	Yes
Optional spacing frame	Yes	Yes	Yes
Water connections	2 x 22mm	2 x 22mm	3 x 22mm
Flues			
Max horizontal Ø60/100	10m	10m	10m
Max vertical Ø60/100	10m	10m	10m
Max horizontal Ø80/125	20m	25m	25m
Max Vertical Ø80/125	20m	25m	25m
Optional plume management kit Ø60/100	Yes	Yes	Yes



- Notes:
- 1 metre from the tap
 - This can be reduced to 5mm for removable panel
 - Upward and downward piping

* Free Glow-worm 5 year warranty available on all Flexicom and Ultracom products, when claimed through Club Energy. www.glow-wormclubenergy.co.uk 0845 2757018

The Ultracom₂ 35 Store

Ultracom₂ 35 Store specifications - Storage Combi

Ultracom	35 Store
Size	
Casing dimensions (h w d)(mm)	890 x 470 x 561
Weight (lift)	67kg
Performance	
CH output (kW) Min/Max	8.5/30.0
CH condensing Max output (kW)	30.0
DHW output (kW)	8.7/35.7
DHW flow rate (l/min, 35°C rise)	19.7
SEDBUK SAP 2009 rating (%)	89.4%
SEDBUK SAP 2005 rating (%)	90.6%
NOx class 5 (natural gas)	Yes
Adjustable to LPG	Yes
Construction	
Main heat exchanger type	Coiled tube
Heat exchanger material	Stainless steel
Burner type	Pre-mixed
Fully modulating	Yes
DHW plate heat exchanger	Yes
Integrated hydrobloc	Yes
Installation	
Suitable for sealed systems	Yes
Suitable for regular heat only systems	No
Inbuilt condensate trap	Yes
Inbuilt boiler frost protection	2 stage
Zero compartment ventilation	Yes
Clearances	
Top (mm) (from top of boiler)	300
Side (mm)	50 Left/150 Right
Bottom (mm)	300
Front (mm) ¹	600
User Interface	
User display	Digital/plain text
Diagnostics	Advanced/intuitive
User adjustable CH temp control	Yes
Inbuilt digital programmer	No
User adjustable DHW temp control	Yes
'Eco' setting on DHW	Yes
Optional programmable room thermostat	Yes
Pipes	
Optional DIN conversion kit	Yes
Optional rear piping kit	No
Water connections	4 x 22mm
Flues	
Max horizontal Ø60/100	10m
Max vertical Ø60/100	10m
Max horizontal Ø80/125	12m
Max vertical Ø80/125	13m
Optional plume management kit Ø60/100	Yes

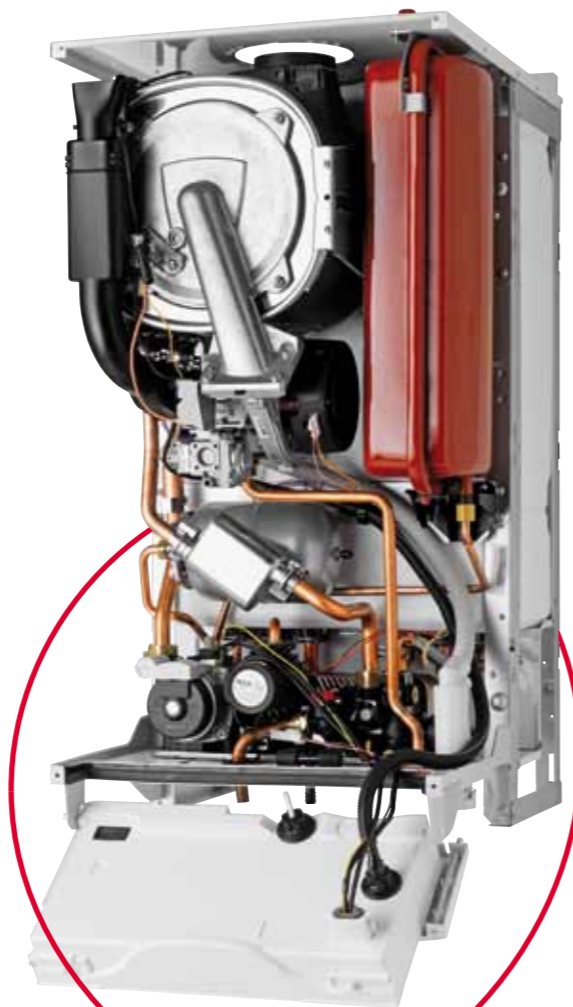

The Ultracom hxi range

Ultracom hxi specifications - Regular heat only

Ultracom	12hxi	15hxi	18hxi	24hxi	30hxi	38hxi
Size						
Casing dimensions (h w d)(mm)	610 x 375 x 334	610 x 375 x 334	610 x 375 x 334	610 x 375 x 334	610 x 375 x 334	610 x 375 x 334
Weight (lift)	28kg	28kg	28kg	31kg	31kg	31kg
Performance						
CH output (kW) Min/Max	5.0/12.0	5.0/15.0	5.0/18.6	5.3/24.0	5.3/28.2	6.3/38.0
CH condensing Max output (kW)	12.9	16.2	20.2	25.0	30.6	41.0
SEDBUK SAP 2009 rating (%)	88.7	88.7	88.6	88.9	88.7	89.2
SEDBUK SAP 2005 rating (%)	90.5	90.5	90.4	90.5	90.6	90.8
NOx class 5 (natural gas)	Yes	Yes	Yes	Yes	Yes	Yes
Adjustable to LPG	Yes	Yes	Yes	Yes	Yes	Yes
Construction						
Main heat exchanger type	Coiled tube	Coiled tube	Coiled tube	Coiled tube	Coiled tube	Coiled tube
Heat exchanger material	Stainless steel	Stainless steel	Stainless steel	Stainless steel	Stainless steel	Stainless steel
Burner type	Pre-mixed	Pre-mixed	Pre-mixed	Pre-mixed	Pre-mixed	Pre-mixed
Fully modulating	Yes	Yes	Yes	Yes	Yes	Yes
Installation						
Suitable for sealed systems	Yes	Yes	Yes	Yes	Yes	Yes
Suitable for regular heat only systems	Yes	Yes	Yes	Yes	Yes	Yes
Inbuilt condensate trap/siphon	Yes	Yes	Yes	Yes	Yes	Yes
Inbuilt boiler frost protection	2 stage	2 stage	2 stage	2 stage	2 stage	2 stage
Continua electronics	Yes	Yes	Yes	Yes	Yes	Yes
Zero compartment ventilation	Yes	Yes	Yes	Yes	Yes	Yes
Clearances						
Top (mm) (from top of boiler)	150	150	150	150	150	150
Side (mm)	20	20	20	20	20	20
Bottom (mm)	200	200	200	200	200	200
Front (mm) ¹	600	600	600	600	600	600
User Interface						
User display	Digital	Digital	Digital	Digital	Digital	Digital
Diagnostics	Advanced	Advanced	Advanced	Advanced	Advanced	Advanced
User adjustable CH temp control	Yes	Yes	Yes	Yes	Yes	Yes
Inbuilt digital programmer	Yes ²	Yes ²	Yes ²	Yes ²	Yes ²	Yes ²
Pipes						
Water connections	2 x 22mm	2 x 22mm	2 x 22mm	2 x 22mm	2 x 22mm	2 x 22mm
Flues						
Max horizontal Ø60/100	10m	10m	10m	10m	10m	10m
Max vertical Ø60/100	10m	10m	10m	10m	10m	10m
Max horizontal Ø80/125	25m	25m	25m	25m	25m	25m
Max vertical Ø80/125	25m	25m	25m	25m	25m	25m
Optional plume management kit Ø60/100	Yes	Yes	Yes	Yes	Yes	Yes

Notes:

- ¹ This can be reduced to 5mm for removable panel
- ² Activated with addition of Options Board or Smart Wiring Centre and Glow-worm intelligent controls



* Free Glow-worm 5 year warranty available on all Flexicom and Ultracom products, when claimed through Club Energy. www.glow-wormclubenergy.co.uk 0845 2757018

The Flexicom range

Flexicom cx specifications - Combi

Flexicom	24CX	30CX	35CX
Size			
Casing dimensions (h w d)(mm)	700 x 390 x 280	700 x 390 x 280	700 x 390 x 280
Weight (lift)	36kg	36kg	36kg
Performance			
CH output (kW) Min/Max	9.3/18.0	9.3/24.0	9.3/30.0
DHW output (kW) Min/Max	9.3/25.1	9.3/30.0	9.3/35.0
CH condensing Max output (kW)	18.8	24.9	31.0
DHW flow rate l/min. 35°C rise	9.85	12.3	14.4
DHW response ¹	5 seconds	5 seconds	5 seconds
SEDBUK SAP 2009 rating (%)	88.4	88.3	89.1
SEDBUK SAP 2005 rating (%)	90.3	90.0	90.2
NOx class 5 (natural gas)	Yes	Yes	Yes
Adjustable to LPG	No	No	No
Construction			
Main heat exchanger type	Cast	Cast	Cast
Heat exchanger material	Aluminium	Aluminium	Aluminium
Burner type	Pre-mixed	Pre-mixed	Pre-mixed
Fully modulating	Yes	Yes	Yes
DHW plate heat exchanger	Yes	Yes	Yes
Integrated hydrobloc	Yes	Yes	Yes
Installation			
Suitable for sealed systems	Yes	Yes	Yes
Suitable for regular heat only systems	No	No	No
Filling loop	Integral	Integral	Integral
Flow restrictor	Yes 9.4 l/min	Yes 11.7 l/min	Yes 13 l/min
Inbuilt system bypass	Yes automatic	Yes automatic	Yes automatic
Inbuilt condensate trap/siphon	Yes	Yes	Yes
Inbuilt boiler frost protection	Two stage	Two stage	Two stage
Continua electronics	Yes	Yes	Yes
Zero compartment ventilation	Yes	Yes	Yes



Flexicom cx specifications - Combi (Continued)

Flexicom	24CX	30CX	35CX
Clearances			
Top (mm) (from top of boiler)	150	150	150
Side (mm)	5	5	5
Bottom (mm)	150	150	150
Front (mm) ²	600	600	600
User Interface			
User display	2 Digit LCD	2 Digit LCD	2 Digit LCD
Diagnostics	Advanced	Advanced	Advanced
User adjustable CH temp control	Yes	Yes	Yes
User adjustable DHW temp control	Yes	Yes	Yes
Optional glide down analogue timer	Yes	Yes	Yes
Pipes			
Prefixing jig with DIN layout	Yes	Yes	Yes
Optional spacing frame	Yes	Yes	Yes
Water connections	2 x 22mm 2 x 15mm	2 x 22mm 2 x 15mm	2 x 22mm 2 x 15mm
Flues			
Max horizontal Ø60/100	8m	8m	8m
Max vertical Ø60/100	8m	8m	8m
Max horizontal Ø80/125	20m	20m	20m
Max vertical Ø80/125	20m	20m	20m
Max direct rear flue	0.55m	0.55m	0.55m
Optional plume management kit Ø60/100	Yes	Yes	Yes



Notes:

- 1 metre from the tap
- This can be reduced to 5mm for removable panel

* Free Glow-worm 5 year warranty available on all Flexicom and Ultracom products, when claimed through Club Energy. www.glow-wormclubenergy.co.uk
0845 2757018



The Flexicom range

Flexicom sx specifications - Sealed System

Flexicom	18sx	30sx
Size		
Casing dimensions (h w d)(mm)	700 x 390 x 280	700 x 390 x 280
Weight (lift)	36kg	36kg
Performance		
CH output (kW) Min/Max	9.3/18.0	9.3/30.0
CH condensing Max output (kW)	18.8	31.0
SEDBUK SAP 2009 rating (%)	88.4	88.9
SEDBUK SAP 2005 rating (%)	90.3	90.1
NOx class 5 (natural gas)	Yes	Yes
Adjustable to LPG	No	No
Construction		
Main heat exchanger type	Cast	Cast
Heat exchanger material	Aluminium	Aluminium
Burner type	Pre-mixed	Pre-mixed
Fully modulating	Yes	Yes
Installation		
Suitable for sealed systems	Yes	Yes
Suitable for open-vent systems	No	No
Inbuilt system bypass	Yes automatic	Yes automatic
Inbuilt condensate trap/siphon	Yes	Yes
Inbuilt boiler frost protection	Two stage	Two stage
Continua electronics	Yes	Yes
Zero compartment ventilation	Yes	Yes
Clearances		
Top (mm) (from top of boiler)	150	150
Side (mm)	5	5
Bottom (mm)	150	150
Front (mm) ¹	600	600
User Interface		
User display	2 Digit LCD	2 Digit LCD
Diagnostics	Advanced	Advanced
User adjustable CH temp control	Yes	Yes
Optional inbuilt timer	No	No
Pipes		
Prefixing jig with DIN layout	Yes	Yes
Optional spacing frame	Yes	Yes
Water connections	2 x 22mm	2 x 22mm
Flues		
Max horizontal Ø60/100	8m	8m
Max vertical Ø60/100	8m	8m
Max horizontal Ø80/125	20m	20m
Max vertical Ø80/125	20m	20m
Max direct rear flue	0.55m	0.55m
Optional plume management kit Ø60/100	Yes	Yes



* Free Glow-worm 5 year warranty available on all Flexicom and Ultracom products, when claimed through Club Energy. www.glow-wormclubenergy.co.uk
0845 2757018

Flexicom hx specifications - Regular heat only

Flexicom	12hx	15hx	18hx	24hx	30hx	35hx
Size						
Casing dimensions (h w d)(mm)	600 x 375 x 280	600 x 375 x 280	600 x 375 x 280	600 x 375 x 280	600 x 375 x 280	600 x 375 x 280
Weight (lift)	25kg	25kg	25kg	25kg	25kg	25kg
Performance						
CH output (kW) Min/Max	9.3/12.0	9.3/15.0	9.3/18.0	9.3/24.0	9.3/30.0	9.3/35.0
CH condensing Max output (kW)	12.8	15.8	18.8	24.8	31.0	36.0
SEDBUK SAP 2009 rating (%)	88.5	88.5	88.4	88.4	88.7	89.2
SEDBUK SAP 2005 rating (%)	90.7	90.5	90.4	90.3	90.0	90.3
NOx class 5 (natural gas)	Yes	Yes	Yes	Yes	Yes	Yes
Adjustable to LPG	No	No	No	No	No	No
Construction						
Main heat exchanger type	Cast	Cast	Cast	Cast	Cast	Cast
Heat exchanger material	Aluminium	Aluminium	Aluminium	Aluminium	Aluminium	Aluminium
Burner type	Pre-mixed	Pre-mixed	Pre-mixed	Pre-mixed	Pre-mixed	Pre-mixed
Fully modulating	Yes	Yes	Yes	Yes	Yes	Yes
Suitable for sealed systems	Yes	Yes	Yes	Yes	Yes	Yes
Installation						
Suitable for regular heat only systems	Yes	Yes	Yes	Yes	Yes	Yes
Inbuilt condensate trap/siphon	Yes	Yes	Yes	Yes	Yes	Yes
Inbuilt boiler frost protection	Two stage	Two stage	Two stage	Two stage	Two stage	Two stage
Continua electronics	Yes	Yes	Yes	Yes	Yes	Yes
Zero compartment ventilation	Yes	Yes	Yes	Yes	Yes	Yes
Clearances						
Top (mm) (from top of boiler)	150	150	150	150	150	150
Side (mm)	5	5	5	5	5	5
Bottom (mm)	150	150	150	150	150	150
Front (mm) ¹	600	600	600	600	600	600
User Interface						
User display	2 Digit LCD	2 Digit LCD	2 Digit LCD	2 Digit LCD	2 Digit LCD	2 Digit LCD
Diagnostics	Advanced	Advanced	Advanced	Advanced	Advanced	Advanced
User adjustable CH temp control	Yes	Yes	Yes	Yes	Yes	Yes
Optional inbuilt timer	No	No	No	No	No	No
Pipes						
Prefixing jig with DIN layout	Yes	Yes	Yes	Yes	Yes	Yes
Upward piping kit	Yes	Yes	Yes	Yes	Yes	Yes
Water connections	2 x 22mm	2 x 22mm	2 x 22mm	2 x 22mm	2 x 22mm	2 x 22mm
Flues						
Max horizontal Ø60/100	8m	8m	8m	8m	8m	8m
Max vertical Ø60/100	8m	8m	8m	8m	8m	8m
Max horizontal Ø80/125	20m	20m	20m	20m	20m	20m
Max vertical Ø80/125	20m	20m	20m	20m	20m	20m
Max direct rear flue	0.55m	0.55m	0.55m	0.55m	0.55m	0.55m
Optional plume management kit Ø60/100	Yes	Yes	Yes	Yes	Yes	Yes

Notes:

- This can be reduced to 5mm for removable panel



The Ultrapower range

Ultrapower sxi specifications - System Store

Ultrapower	100sxi	170sxi
Size		
Casing dimensions (h w d)(mm)	1260 x 575 x 600	1520 x 575 x 600
Weight (boiler module lift)	50.5kg	50.5kg
Weight (tank module lift)	39.0kg	48.0kg
Performance		
CH output (kW) Min/Max	8.7/24.3	8.7/24.3
DHW output (kW) Min/Max	8.7/31.0	8.7/31.0
Max DHW flow rate (l/min@2bar)	36	36
DHW flow rate storage/combi (l/min. 35°C rise)	24/12.5	25/12.5
Volume of DHW produced (l)	100	170
DHW response ¹	5 seconds	5 seconds
SEDBUK SAP 2009 rating (%)	89.2	89.3
SEDBUK SAP 2005 rating (%)	91.5	91.5
NOx class 5 (natural gas)	Yes	Yes
Adjustable to LPG	Yes	Yes
Construction		
Main heat exchanger type	Coiled tube	Coiled tube
Heat exchanger material	Stainless steel	Stainless steel
Burner type	Pre-mixed	Pre-mixed
Fully modulating	Yes	Yes
DHW plate heat exchanger	Yes	Yes
Integrated hydrobloc	Yes	Yes
Installation		
Suitable for sealed systems	Yes	Yes
Suitable for open-vent systems	No	No
Filling loop	Yes	Yes
Flow restrictor	No	No
Inbuilt system bypass	Yes	Yes
Inbuilt condensate trap/siphon	Yes	Yes
Inbuilt boiler frost protection	Yes	Yes
Continua electronics	Yes	Yes
Zero compartment ventilation	Yes	Yes
Clearances		
Top (mm) (from top of boiler)	150	150
Side (mm)	5	5
Front (mm) ²	600	600
User Interface		
User display	Digital	Digital
Diagnostics	Advanced	Advanced
User adjustable CH temp control	Yes	Yes
User adjustable DHW temp control	Yes	Yes
Optional programmer	Built-in 7 day two channel	Built-in 7 day two channel
Pipes		
Pre-fixing jig	Yes	Yes
Water connections	4 x 22mm	4 x 22mm
Flues		
Max horizontal Ø60/100	8m	8m
Max vertical Ø60/100	12m	12m
Max horizontal Ø80/125	25m	25m
Max vertical Ø80/125	25m	25m
Optional plume management kit Ø60/100	Yes	Yes



* Free Glow-worm 5 year warranty available on all Flexicom and Ultracom products, when claimed through Club Energy. www.glow-wormclubenergy.co.uk
0845 2757018

Notes:
1 1 metre from the tap

The Hot water cylinder range

Hydracyl unvented hot water cylinders

Hydracyl	150	205	250	300
Size				
Total capacity (l)	150	205	250	300
Actual capacity (l)	149.1	211.2	250.3	299.1
Hot water capacity	136.7	203.9	247.5	270.5
Height (mm)	1191	1593	1843	2153
Height with hot water draw off (mm)	1223	1625	1875	2185
Diameter (mm)	554.5	554.5	554.5	554.5
Depth (mm)	633	633	633	633
Net weight (kg)	29	36	41	46
Weight full (kg)	177.8	248	291	345
Construction				
Cylinder body material	Stainless steel (1.4521)			
Cylinder jacket material	Polypropylene			
Insulation material	EPS with infrared absorber			
Insulation thickness (mm)	50.0			
Corrosion protection	Stainless steel			
Blowing agent for insulation material	Pentane (GWP < 5)			
ODP	0			
Performance				
Standing heat loss (kW/24 h)	1.61	1.98	2.17	2.37
Heating up time according to EN 12897 (mins)	24	30	37	42
Recovery time (70% capacity) (mins)	19	21	26	31
Primary heat exchanger performance (kW)	18	21.4	21	20
Flow rate for primary heat exchanger performance (l/min)	23.3	23.3	23.3	23.3
Primary heat exchanger pressure drop (mbar)	97	116	116	115
Primary heat exchanger volume (l)	2.94	3.56	3.56	3.56
Primary heat exchanger surface area (m ²)	0.62	0.75	0.75	0.75
Installation				
Cold water inlet	22mm unprofiled pipe (compression joints)			
Hot water draw off	22mm unprofiled pipe (compression joints)			
Balanced pressure cold water outlet	22mm unprofiled pipe (compression joints)			
Secondary return	22mm unprofiled pipe (compression joints)			
Primary heater flow	22mm unprofiled pipe (compression joints)			
Primary heater return	22mm unprofiled pipe (compression joints)			
Primary heating circuit immersion sleeve size (mm)	8			
Immersion heater (according to BS EN 60335)	2.7kW, 230 V, 50 Hz			
Length of electric immersion heater (inch)	14			
Two port motorised valve	2.7kW, 230 V, 50 Hz			
Cylinder thermostat	2.7kW, 230 V, 50 Hz			
Safety				
Maximum supply pressure to pressure reducing valve (bar)	12			
Maximum operating pressure of cylinder (bar)	7			
Maximum operating pressure of heating coil (bar)	3.5			
Operating pressure (bar)	3.5			
Pressure limiting valve (bar)	3.5			
Expansion relief valve (bar)	6			
Temperature and pressure relief valve °C/bar	90/7.0			
Charge pressure of hot water expansion vessel	4			
Maximum temperature of heating circuit °C	85			
Maximum temperature of potable hot water °C	85			

The Hot water cylinder range

Flurocyl₂ solar hot water cylinders

Flurocyl ₂	200	250	300
Size			
Total capacity (l)	200	250	300
Actual capacity (l)	209.4	254.4	297.2
Hot water capacity (upper coil) (l)	104.8	142	144.2
Hot water capacity (solar coil) (l)	203.3	246.1	271.1
Dedicated solar volume (l)	104.6	112.4	153
Height (mm)	1593	1843	2153
Height with hot water draw off (mm)	1625	1875	2185
Diameter (mm)	554.5	554.5	554.5
Depth (mm)	633	633	633
Net weight (kg)	40	43	50
Weight full (kg)	249	298	347
Construction			
Cylinder body material	Stainless steel (1.4521)		
Cylinder jacket material	Polypropylene		
Insulation material	EPS with infrared absorber		
Insulation thickness (mm)	50.0		
Corrosion protection	Stainless steel		
Blowing agent for insulation material	Pentane (GWP < 5)		
ODP	0		
Performance			
Standing heat loss (kW/24 h)	2.05	2.2	2.4
Heating up time according to EN 12897 (mins)	22	29	30
Recovery time (70% capacity) (mins)	16	21	22
Primary heat exchanger performance (kW)	14.9	15.3	15
Flow rate for primary heat exchanger performance (l/min)	23.3	23.3	23.3
Primary heat exchanger pressure drop (mbar)	79	78	79
Primary heat exchanger volume (l)	2.37	2.37	2.37
Primary heat exchanger surface area (m ²)	0.5	0.5	0.5
Solar heat exchanger performance (kW)	18.7	18.5	16.5
Flow rate for solar heat exchanger performance (l/min)	23.3	23.3	23.3
Solar heat exchanger pressure drop (mbar)	97	95	98
Solar heat exchanger volume (l)	2.94	2.94	2.94
Solar heat exchanger surface area (m ²)	0.62	0.62	0.62
Heating up time according to EN 12897 (solar)	22	29	30
Installation			
Cold water inlet	22mm unprofiled pipe (compression joints)		
Hot water draw off	22mm unprofiled pipe (compression joints)		
Balanced pressure cold water outlet	22mm unprofiled pipe (compression joints)		
Secondary return	22mm unprofiled pipe (compression joints)		
Primary heater flow	22mm unprofiled pipe (compression joints)		
Primary heater return	22mm unprofiled pipe (compression joints)		
Solar heater flow	22mm unprofiled pipe (compression joints)		
Solar heater return	22mm unprofiled pipe (compression joints)		
Primary heating circuit immersion sleeve size (mm)	8		
Solar heating circuit immersion sleeve size (mm)	8		
Immersion heater (according to BS EN 60335)	2.7kW, 230 V, 50 Hz		
Length of electric immersion heater (inch)	14		
Two port motorised valve	2.7kW, 230 V, 50 Hz		
Cylinder thermostat	2.7kW, 230 V, 50 Hz		
Safety			
Maximum supply pressure to pressure reducing valve (bar)	12		
Maximum operating pressure of cylinder (bar)	7		
Maximum operating pressure of heating coil (bar)	3.5		
Maximum operating pressure of solar coil (bar)	6		
Operating pressure (bar)	3.5		
Pressure limiting valve (bar)	3.5		
Expansion relief valve (bar)	6		
Temperature and pressure relief valve (bar)	7		
Charge pressure of hot water expansion vessel	4		
Maximum temperature of heating circuit °C	85		
Maximum temperature of solar fluid °C	85		

Product dimensions

Range	A	B	C	D	E	F	F
	Height	Width	Depth	Flue Outlet position 1	Flue outlet position 2	Ø60/100 Flue diameter	Ø80/125 Flue diameter
Ultracom							
Ultracom ₂ cxi (mm)	740	418	346	130	0 ¹	100	125
Ultracom ₂ sxi (mm)	740	418	346	130	0 ¹	100	125
Ultracom ₂ 35 Store (mm)	890	470	561	361	0 ¹	100	125
Ultracom hxi (mm)	610	375	334	176	53	100	125
Flexicom							
Flexicom cx (mm)	700	390	280	149	47	100	125
Flexicom hx (mm)	600	375	280	149	52	100	125
Flexicom sx (mm)	700	390	280	149	47	100	125
Ultrapower							
Ultrapower sxi 100 (mm)	1260	575	600	145	106.5	100	125
Ultrapower sxi 170 (mm)	1520	575	600	145	106.5	100	125

Ultracom & Flexicom

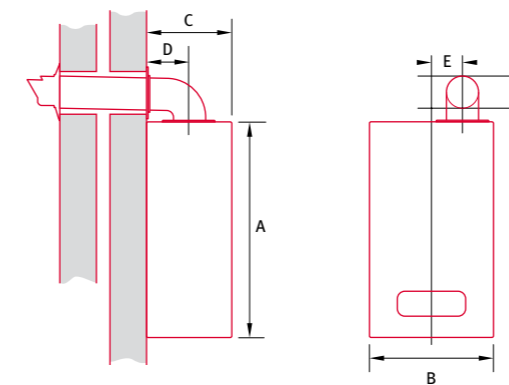

Flexicom available with direct rear flue

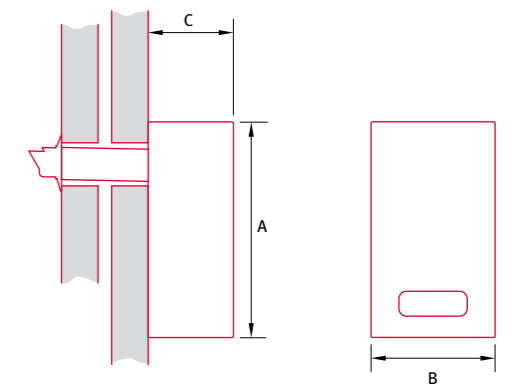

Ultrapower

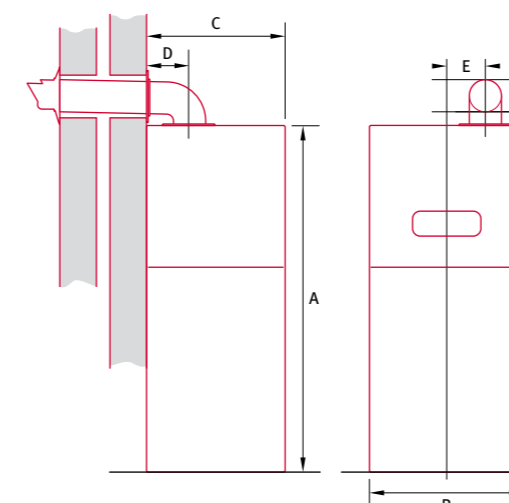

Product clearances

Range	A	B	C	D	E	F	G
	Top flue	Top	Side	Bottom	Flue#1	Flue#2	Front
Ultracom							
Ultracom ₂ cxi (mm)	150	5	0	200	5	5	600 ²
Ultracom ₂ sxi (mm)	150	5	0	200	5	5	600 ²
Ultracom ₂ 35 Store (mm)	300	5	50 Left 150 Right	300	5	5	600 ²
Ultracom hxi (mm)	150	5	20	200	5	5	600 ²
Flexicom							
Flexicom cx (mm)	150 ³	5	5	150	5	5	600 ²
Flexicom hx (mm)	150 ³	5	5	150	5	5	600 ²
Flexicom sx (mm)	150 ³	5	5	150	5	5	600 ²
Ultrapower							
Ultrapower sxi 100 (mm)	150	5	5	n/a	5	5	600 ²
Ultrapower sxi 170 (mm)	150	5	5	n/a	5	5	600 ²

Ultracom & Flexicom

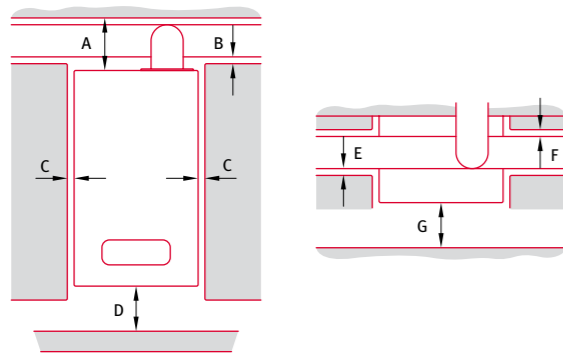

Ultrapower

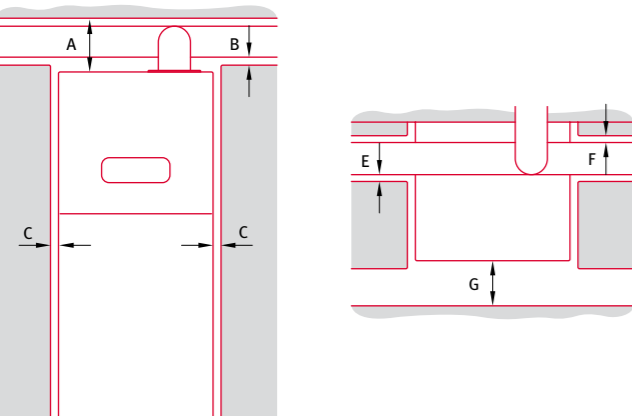

Notes:

- 1 Flue is central to the boiler.
- 2 A removable compartment door can be placed at least 5mm in front of the appliance.
- 3 This can be reduced to 20mm if using a direct rear flue.

Horizontal flueing options

Horizontal flue lengths

The horizontal flueing information below applies to all Glow-worm High Efficiency boilers.

Boiler	Ø60/100 Max horizontal	Ø80/125 Max horizontal	Compatible with Plume Management Kit
Ultracom ₂ cxi	10m	25m	Yes ¹
Ultracom ₂ sxi	10m	25m	Yes ¹
Ultracom ₂ 12 sxi	10m	20m	Yes ¹
Ultracom ₂ 35 Store	10m	12m	Yes ¹
Ultracom hxi	10m	25m	Yes ¹
Flexicom	8m	20m	Yes ¹
Ultrapower	8m	25m	Yes ¹

Notes:

- 1 The overall maximum flue length must not be exceeded

Top rear and top side horizontal flue options

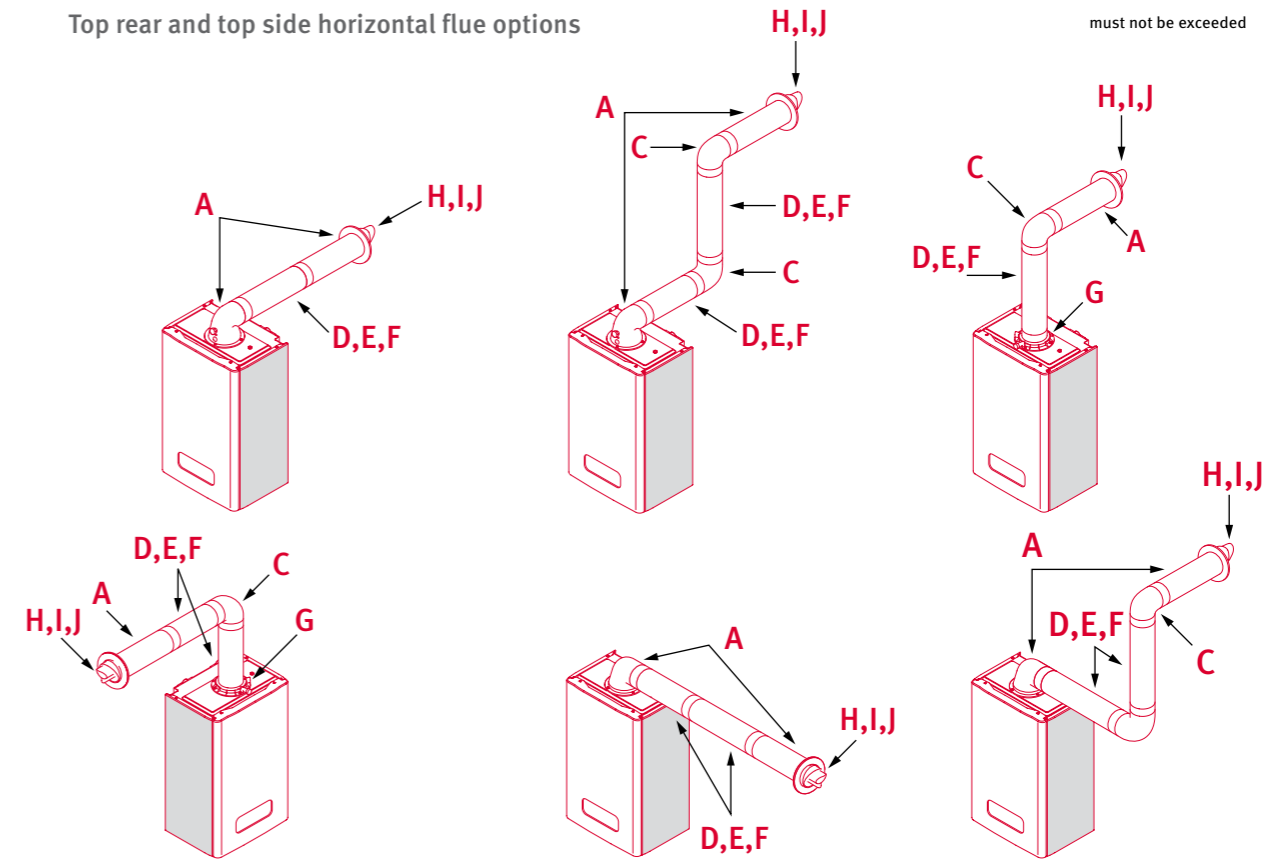

Horizontal flue accessories

Component	Description	Part Number Ø60/100	Part Number Ø80/125
A	Horizontal Telescopic flue	A2043600	0020104551
B	45° Bend (2 off)	2000460485	0020104557
C	90° Bend (1 off)	2000460484	0020104556
D	0.5m Extension (1 off)	2000460481	0020104553
E	1m Extension (1 off)	2000460482	0020104554
F	2m Extension (1 off)	2000460483	0020104555
G	Vertical Flue Adaptor	A2024600	0020104550
H	Deflector Terminal (Black)	0020060582	-
I	Deflector Terminal (White)	0020060583	-
J	Black Terminal	A2043700	-

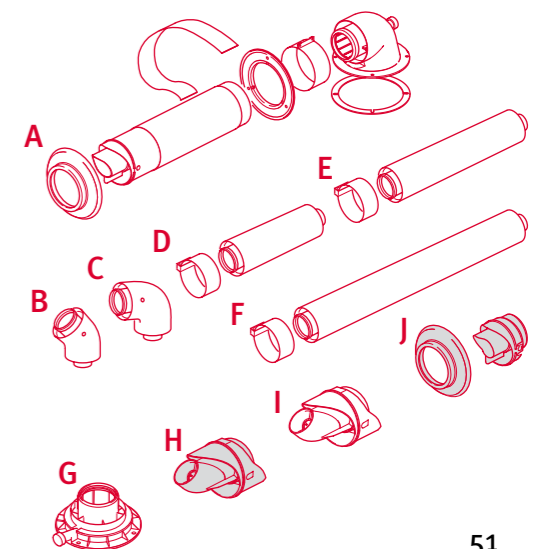

Vertical flueing options

Vertical flue lengths

The vertical flueing information below applies to all Glow-worm High Efficiency boilers.

Boiler	Ø60/100 Max vertical	Ø80/125 Max vertical	Compatible with Plume Management Kit
Ultracom ₂ cxi	10m	25m	Yes ¹
Ultracom ₂ sxi	10m	25m	Yes ¹
Ultracom ₂ 12 sxi	10m	20m	Yes ¹
Ultracom ₂ 35 Store	10m	13m	Yes ¹
Ultracom hxi	10m	25m	Yes ¹
Flexicom	8m	20m	Yes ¹
Ultrapower	12m	25m	Yes ¹

Vertical flue options

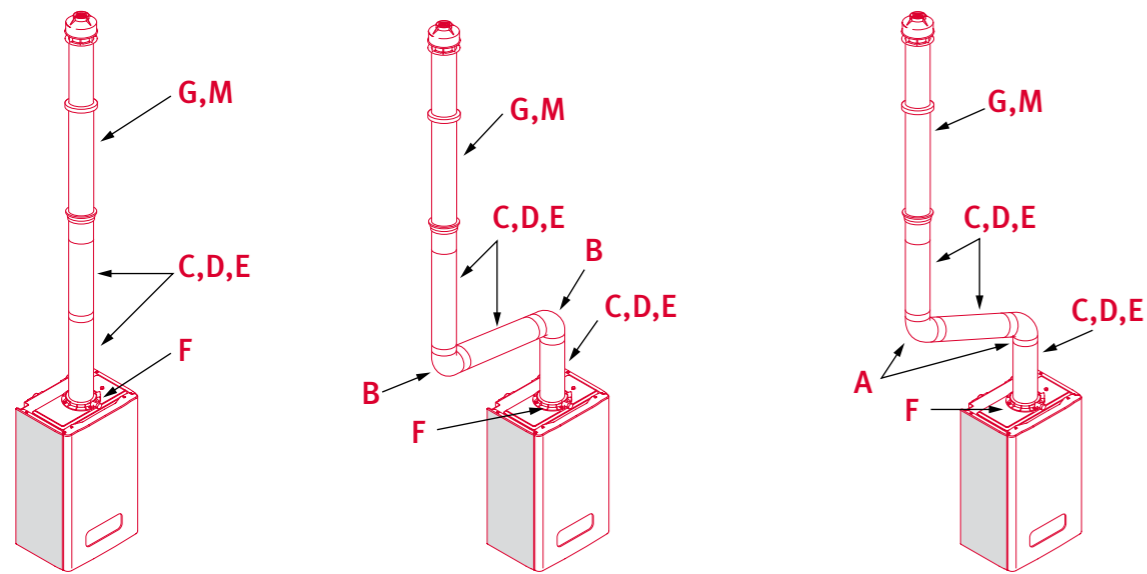

Notes:

- i Horizontal sections must have a continuous fall of at least 2.5° (44mm/metre) back to the boiler.

Vertical flue accessories

Component	Description	Part Number Ø60/100	Part Number Ø80/125
A	45° Bend (2 off)	2000460485	0020104557
B	90° Bend (1 off)	2000460484	0020104556
C	0.5m Extension (1 off)	2000460481	0020104553
D	1m Extension (1 off)	2000460482	0020104554
E	2m Extension (1 off)	2000460483	0020104555
F	Vertical Flue Adaptor	A2024600	0020104550
G	Vertical Roof Terminal	2000460480	0020104552
H	Pitched Roof Flashing	2000460479	-
I	Flat Roof Flashing	2000460478	-
J	Sliding Sleeve	2000460487	0020104558
K	Fixing Bracket (5 off)	2000460486	0020104559
L	Telescopic Extension	A2036900	-
M	Ridge Tile Terminal	A2043800	-

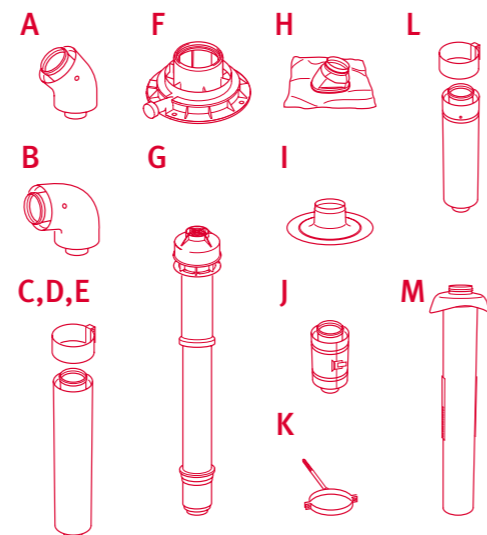

Notes:

- 1 The overall maximum flue length must not be exceeded

Direct rear flueing options

Direct rear flue lengths

The direct rear flueing information below applies to the Glow-worm Flexicom range of High Efficiency boilers only.

Boiler	Max Direct Rear
Flexicom	0.55m

Direct rear flue option

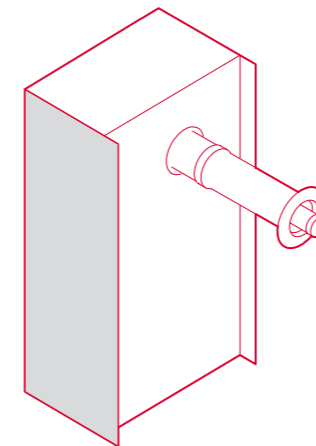

Flueing example using Horizontal Telescopic Rear Flue A2043500

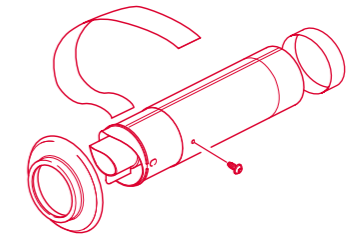

Flueing accessories

Plume Management Kit accessories

Compatible with all Glow-worm High Efficiency boilers

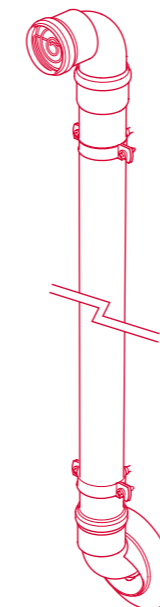

Component	Description	Part Number
A	45° Bend Black (2 off)	A2044400
B	45° Bend White (2 off)	A2044500
C	90° Bend Black	A2044600
D	90° Bend White	A2044700
E	1m Extension Black	A2044200
F	1m Extension White	A2044300
G	Plume Management Kit White	A2044100
H	Plume Management Kit Black	A2044000

Notes:

- i Maximum flue lengths must not exceed 6m and be added to the total flue length calculation.
- ii For each additional 90° or 2 x 45° bends fitted, the maximum lengths must be reduced by 1m.

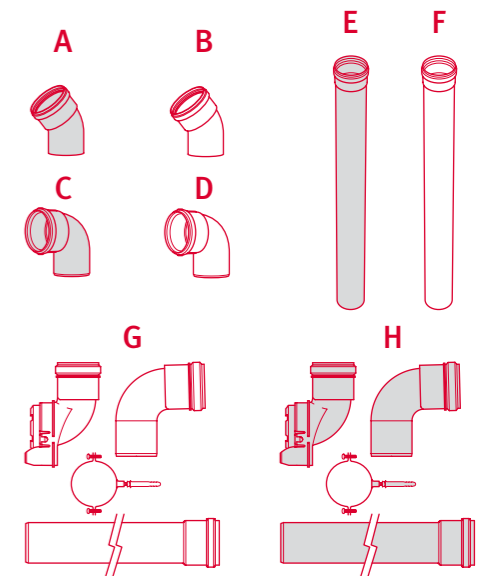

Optiflue

Boiler	Max Horizontal	Max Vertical
Ultracom ₂ 24cxi	3m + elbow	7m
Ultracom ₂ 30cxi	3m + elbow	7m
Ultracom ₂ 35cxi	2m + elbow	5m

Notes:

Flue length is reduced by 1m for each additional 87° elbow and by 0.5m for each additional 45° elbow

Optiflue is also fully compatible with current Glow-worm vertical flue range

Control options

Ultracom₂ cxi control options

	Ultracom ₂ cxi	Climastat	Wired Climapro ₁	Wireless Climapro ₂ RF/ Climapro ₁ RF	Wired Outdoor Sensor	Wireless Outdoor Sensor	Plug in analogue or digital timer	Smart Wiring Centre
To achieve room compensation you will need:								
Using plug in controls	✓	+	✓	+	x	x	x	x
or								
Using external controls	✓	+	x	✓	or	✓	x	x
To achieve weather compensation you will need:								
Using plug in controls	✓	+	✓	+	x	x	✓	+
or								
Using external controls (Wired)	✓	+	x	✓	+	x	✓	+
Using external controls (Wireless)	✓	+	x	x	✓	+	x	x

Ultracom₂ sxi control options

	Ultracom ₂ sxi	Climastat	Wired Climapro ₁	Wireless Climapro ₂ RF/ Climapro ₁ RF	Wired Outdoor Sensor	Wireless Outdoor Sensor	Plug in digital timer	Smart Wiring Centre
To achieve room compensation you will need:								
Using plug in controls	✓	+	✓	+	x	x	x	✓
or								
Using external controls	✓	+	x	✓	or	✓	+	✓
To achieve weather compensation you will need:								
Using plug in controls	✓	+	✓	+	x	x	✓	+
or								
Using external controls (Wired)	✓	+	x	✓	+	x	x	✓
Using external controls (Wireless)	✓	+	x	x	✓	+	x	✓

Ultracom₂ 35 Store control options

	Ultracom ₂ 35 Store	Climastat	Wired Climapro ₁	Wireless Climapro ₂ RF/ Climapro ₁ RF	Wired Outdoor Sensor	Wireless Outdoor Sensor	Plug in digital timer	Smart Wiring Centre
To achieve room compensation you will need:								
Using external controls	✓	+	x	✓	or	✓	x	x
To achieve weather compensation you will need:								
Using external controls (Wired)	✓	+	x	✓	+	x	x	x
Using external controls (Wireless)	✓	+	x	x	✓	+	x	x

Ultracom hxi control options

	Ultracom hxi	Climastat	Wired Climapro ₁	Wireless Climapro ₂ RF/ Climapro ₁ RF	Wired Outdoor Sensor	Wireless Outdoor Sensor	Options Board	Smart Wiring Centre
To achieve room compensation you will need:								
Using inbuilt programmer	✓	+	✓	+	x	x	x	✓
or								
Using external controls	✓	+	x	✓	or	✓	+	✓
To achieve weather compensation you will need:								
Using inbuilt programmer	✓	+	✓	+	x	x	✓	+
or								
Using external controls (Wired)	✓	+	x	✓	+	x	x	✓
Using external controls (Wireless)	✓	+	x	x	✓	+	x	✓
To achieve on/off control you will need:								
Using inbuilt programmer	✓	+	✓	+	x	x	✓	x

Control options

Flexicom cx control options

	Flexicom cx	Climastat	Wired Climapro ₁	Wireless Climapro ₂ RF/ Climapro ₁ RF	Wired Outdoor Sensor	Wireless Outdoor Sensor	Glide down analogue timer	Smart Wiring Centre
To achieve room compensation you will need:								
Using glide down analogue timer	✓	+	✓	+	x	x	x	✓
or								
Using external controls	✓	+	x	✓	or	✓	x	x
To achieve weather compensation you will need:								
Using glide down analogue timer	✓	+	✓	+	x	x	✓	+
or								
Using external controls (Wired)	✓	+	x	✓	+	x	x	x
Using external controls (Wireless)	✓	+	x	x	✓	+	x	x

Flexicom hx / sx control options

	Flexicom hx / sx	Climastat	Wired Climapro ₁	Wireless Climapro ₂ RF/ Climapro ₁ RF	Wired Outdoor Sensor	Wireless Outdoor Sensor	Smart Wiring Centre
To achieve room compensation you will need:							
Using external controls	✓	+	x	✓	or	✓	+
To achieve weather compensation you will need:							
Using external controls (Wired)	✓	+	x	✓	+	x	✓
or							
Using external controls (Wireless)	✓	+	x	x	✓	+	✓

Ultracom sxi control options

	Ultracom sxi	Climastat	Wired Climapro ₁	Wireless Climapro ₂ RF/ Climapro ₁ RF	Wired Outdoor Sensor	Wireless Outdoor Sensor
To achieve room compensation you will need:						
Using inbuilt programmer	✓	+	✓	x	x	x
or						
Using external controls	✓	+	x	✓	or	✓
To achieve weather compensation you will need:						
Using external controls (Wired)	✓	+	x	✓	+	x
or						
Using external controls (Wireless)	✓	+	x	x	✓	+

Note:

Satisfies Part L requirements for time and temperature control when used in the above configurations
230V Room Thermostat cannot achieve room or weather compensation

Colours are subject to the print process and may not be an accurate representation.

Glow-worm reserve the right to make any modifications to product specifications, or any other details, without prior notification.

For further clarification, please enquire in writing to the head office address on the reverse of this brochure.



Glow-worm

Nottingham Road
Belper
Derbyshire
DE56 1JT

Head Office:
01773 824 639

Literature:
01773 596 105

After Sales Service:
Boilers
01773 828 100
Renewables
01773 596 150

Technical Support & Training:
Advice:
01773 596 156

Boilers
01773 828 300
Renewables
08447 361 143

Spare Parts:
01773 596090



www.glow-worm.co.uk

INVESTOR IN PEOPLE

Glow•worm