

For illustrative purposes only

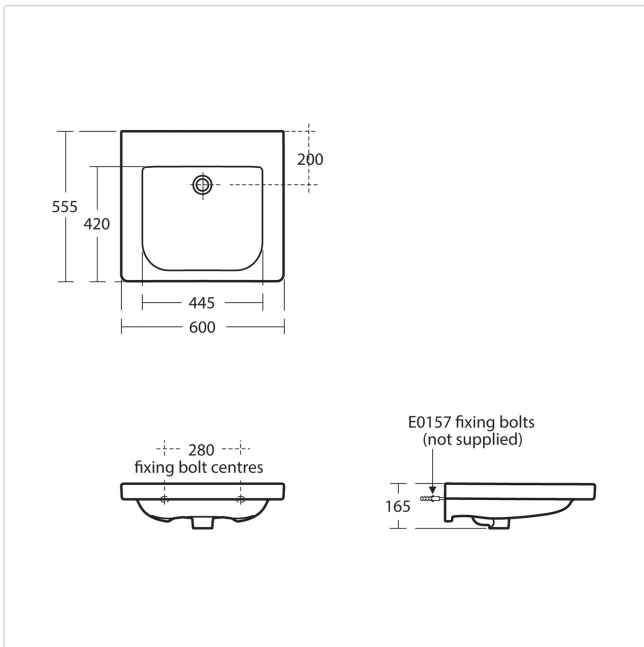

Concept Freedom 60cm Accessible Washbasin

Illustrated

- E5501** Concept Freedom 60cm accessible washbasin, no taphole
- E0157** Wall fixing set
- E0064** Silver dual control three hole wall mounted basin mixer with 230mm projection spout - lever handles
- E0079** Trap 1 1/4" Contemporary metal bottle, 75mm seal

Configuration options

- A6169** Sensorflow Wave Thermostatic basin mixer built-in 230mm spout(mains)

Material

Vitreous China

Weights

- E5501 14.00KG
- E0157 0.16KG
- E0064 2.20KG
- E0079 1.45KG

Colours

White (01)

Standards

Vitreous china to BS 3402.
Washbasin to BS EN 14688 & BS EN 31. Conforms to Doc M and HTM 04

Special Notes

Suitable for use in public areas and Doc M. Satisfies DDA requirements. Washbasin wall mounted using E0157 rag bolts. Please refer to NBN 00-10 Part C sanitary ware assembly for installation heights in healthcare applications.

Designer

Robin Levien, RDI

Frequently used applications

- Hospitals
- Office
- Hotels
- Public Building

Features

- DocM
- HTM



Tel: 0870 122 8822
Fax: 0870 122 8282
Email: info@idealspec.co.uk
Web: www.idealspec.co.uk

Ideal Standard (UK) Ltd. makes every effort to ensure that the information provided on its website is accurate. However, we cannot guarantee this, and accept no liability for any information or advice given via its website.



Date created:27/02/2015