



UNVENTED MAINS PRESSURE WATER HEATERS 120, 150, 170, 210, 250 and 300 LITRE CAPACITY INDIRECT MODELS INSTALLATION AND SERVICING INSTRUCTIONS

PACK CONTENTS

The CENTERSTORE unvented cylinder water heater incorporating immersion heater(s) and thermal controls | Factory fitted temperature/pressure relief valve | Cold water combination valve assembly | Expansion vessel and mounting bracket | Tundish | Motorised valve | Compression nuts and olives | Immersion heater spanner | Installation instructions

IMPORTANT: PLEASE READ AND UNDERSTAND THESE INSTRUCTIONS BEFORE COMMENCING INSTALLATION. PLEASE LEAVE THIS MANUAL WITH THE CUSTOMER FOR FUTURE REFERENCE.



THE BENCHMARK SCHEME

Benchmark places responsibilities on both manufacturers and installers. The purpose is to ensure that customers are provided with the correct equipment for their needs, that it is installed, commissioned and serviced in accordance with the manufacturer's instructions by competent persons and that it meets the requirements of the appropriate Building Regulations. The Benchmark Checklist can be used to demonstrate compliance with Building Regulations and should be provided to the customer for future reference.

Installers are required to carry out installation, commissioning and servicing work in accordance with the Benchmark Code of Practice which is available from the Heating and Hotwater Industry Council who manage and promote the Scheme. Visit www.centralheating.co.uk for more information.

IMPORTANT NOTE TO USER: PLEASE REFER TO THE USER INSTRUCTIONS SECTION ON PAGES 13 AND 14 FOR IMPORTANT INFORMATION WITH RESPECT TO THE BENCHMARK SCHEME

INTRODUCTION

The CENTERSTORE cylinder is a purpose designed unvented water heater. The unit has a stainless steel inner vessel, which ensures an excellent standard of corrosion-resistance. The outer casing is a combination of resilient thermoplastic mouldings and plastic coated corrosion proofed steel sheet. All products are insulated with CFC free polyurethane foam to give good heat loss performance. (See Table 6)

The unit is supplied complete with all the necessary safety and control devices needed to allow connection to the cold water mains. All these components are preset and not adjustable.

This appliance complies with the requirements of the CE marking directive and is Kiwa approved to show compliance with Building Regulations (Section G3).

The following instructions are offered as a guide to installation which must be carried out by a competent plumbing and electrical installer in accordance with Building Regulation G3, The Building Standards (Scotland) Regulations 1990, or The Building Regulations (Northern Ireland).

NOTE: Prior to installation the unit should be stored in an upright position in an area free from excessive damp or humidity.

Contents

PAGE

INTRODUCTION.....	1
GENERAL REQUIREMENTS.....	3
INSTALLATION-GENERAL.....	4
INSTALLATION.....	10
COMMISSIONING.....	12
MAINTENANCE.....	12
USER INSTRUCTIONS.....	13
FAULT FINDING AND SERVICING.....	14
OTHER INFORMATION.....	16
ENVIRONMENTAL INFORMATION.....	16
COMMISSIONING CHECK LIST.....	17
SERVICE RECORD.....	18
GUARANTEE.....	19
TECHNICAL SUPPORT AND SPARES.....	20

IMPORTANT: THIS APPLIANCE IS NOT INTENDED FOR THE USE BY PERSONS (INCLUDING CHILDREN) WITH REDUCED PHYSICAL, SENSORY OR MENTAL CAPABILITIES, OR LACK OF KNOWLEDGE AND EXPERIENCE, UNLESS THEY HAVE BEEN GIVEN SUPERVISION OR INSTRUCTION CONCERNING THE USE OF THE APPLIANCE BY A PERSON RESPONSIBLE FOR THEIR SAFETY. CHILDREN MUST BE SUPERVISED.

GENERAL REQUIREMENTS

SITING THE UNIT

The CENTERSTORE cylinder must be vertically floor mounted. Although location is not critical, the following points should be considered:

- The CENTERSTORE cylinder should be sited to ensure minimum dead leg distances, particularly to the point of most frequent use.
- Avoid siting where extreme cold temperatures will be experienced. All exposed pipe work should be insulated.
- The discharge pipework from the safety valves must have minimum fall of 1:200 from the unit and terminate in a safe and visible position.
- Access to associated controls and immersion heaters must be available to provide for the servicing and maintenance of the system. Where these controls are installed against a wall a minimum distance of **250mm** must be left (see Fig. 1).
- Ensure that the floor area for the CENTERSTORE cylinder is level and capable of permanently supporting the weight when full of water. (see Table 1)

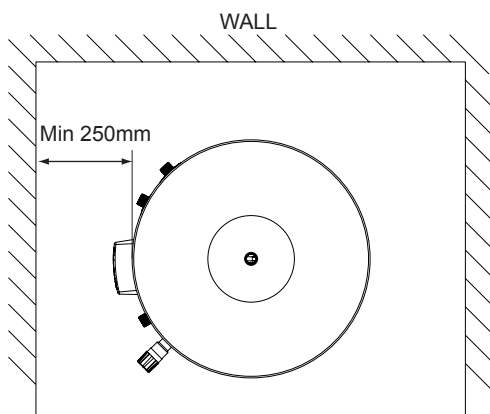

Fig. 1: Siting the Unit

Type	Capacity (litres)	Weight of full unit (kg)
Indirect	120	147
	150	181
	170	204
	210	257
	250	300
	300	360

Table 1: Unit weights

WATER SUPPLY

Bear in mind that the mains water supply to the property will be supplying both the hot and cold water requirements simultaneously. **It is recommended that the maximum water demand is assessed and the water supply checked to ensure this demand can be satisfactorily met.**

Note: A high mains water pressure will not always guarantee high flow rates.

Wherever possible the mains supply pipe should be 22mm. We suggest the minimum supply requirements should be 1.5 bar pressure and 20 litres per minute flowrate. However, at these values outlet flow rates may be poor if several outlets are used simultaneously. The higher the available pressure and flow rate the better the system performance.

The CENTERSTORE cylinder has an operating pressure of 3.5 bar which is controlled by the cold water combination valve assembly. The cold water combination valve assembly can be connected to a maximum mains pressure of 16 bar.

OUTLET/TERMINAL FITTINGS (TAPS, ETC.)

The CENTERSTORE cylinder can be used with most types of terminal fittings. It is advantageous in many mixer showers to have balanced hot and cold water supplies. In these instances a balanced pressure cold water connection should be placed between the 2 pieces of the cold water combination valve assembly (see Fig. 2). Outlets situated higher than the CENTERSTORE cylinder will give outlet pressures lower than that at the heater, a 10m height difference will result in a 1 bar pressure reduction at the outlet. All fittings, pipework and connections must have a rated pressure of at least 6 bar at 80°C.

LIMITATIONS

The CENTERSTORE cylinder should not be used in association with any of the following:

- Solid fuel boilers or any other boiler in which the energy input is not under effective thermostatic control, unless additional and appropriate safety measures are installed.
- Ascending spray type bidets or any other class 1 back syphonage risk requiring that a type A air gap be employed.
- Steam heating plants unless additional and appropriate safety devices are installed.
- Situations where maintenance is likely to be neglected or safety devices tampered with.
- Water supplies that have either inadequate pressure or where the supply may be intermittent.
- Situations where it is not possible to safely pipe away any discharge from the safety valves.
- In areas where the water consistently contains a high proportion of solids, e.g. suspended matter that could block the strainer, unless adequate filtration can be ensured.

OPERATIONAL SUMMARY

Maximum mains pressure	16 bar
Operating pressure	3.5 bar
Expansion vessel charge pressure	3.5 bar
Expansion relief valve setting	6 bar
T&P relief valve setting	90°C/10 bar
Maximum primary circuit pressure	3 bar
Storage capacity	See Table1
Weight when full	See Table1

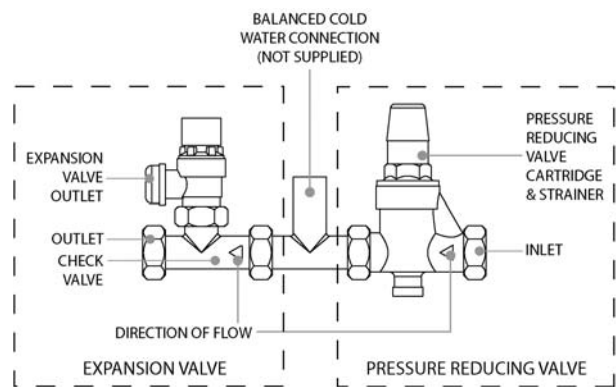

Fig. 2: Cold water combination valve assembly

INSTALLATION – GENERAL (SEE FIGS. 2 - 6)

PIPE FITTINGS

All pipe fittings are made via 22mm compression fittings directly to the unit. The fittings are threaded 3/4" BSP male parallel should threaded pipe connections be required.

COLD FEED

A 22mm cold water supply is recommended, however, if a 15mm (1/2") supply exists, which provides sufficient flow, this may be used (although more flow noise may be experienced).

A stopcock or servicing valve should be incorporated into the cold water supply to enable the CENTERSTORE cylinder and its associated controls to be isolated and serviced.

COLD WATER COMBINATION VALVE ASSEMBLY (FIG. 2)

The 2-piece cold water combination valve assembly can be located anywhere on the cold water mains supply prior to the expansion vessel (see Fig. 6) but the two pieces do not have to be installed together. The pressure reducing valve incorporates the pressure reducer & strainer and the expansion valve incorporates the expansion & check valves. Ensure that the valves are installed in the correct order and orientation. No other valves should be placed between the expansion valve and the CENTERSTORE cylinder.

A connection can be made between the expansion and pressure reducing valves to provide a balanced cold water connection. The expansion valve connection must not be used for any other purpose.

DRAIN TAP

A suitable draining tap should be installed in the cold water supply to the CENTERSTORE cylinder between the expansion valve (see Fig. 6) and the heater at as low a level as possible.

It is recommended that the outlet point of the drain pipework be at least 1 metre below the level of the heater (this can be achieved by attaching a hose to the drain tap outlet spigot).

EXPANSION VESSEL

The expansion vessel accommodates expansion that results from heating the water inside the unit. The expansion vessel is pre-charged at 3.5 bar. The expansion vessel must be connected between the expansion valve (see Fig. 2) and the CENTERSTORE cylinder (see Fig. 6). The location of the expansion vessel should allow access to recharge the pressure as and when necessary, this can be done using a normal car foot pump. It is recommended that the expansion vessel is adequately supported. An expansion vessel wall mounting bracket is supplied for this purpose and should be fitted.

SECONDARY CIRCULATION

If secondary circulation is required it is recommended that it be connected to the CENTERSTORE cylinder as shown in Fig. 3 via a swept tee joint into the cold feed to the unit. A swept tee joint is available as an accessory (order code no. 5133565).

The secondary return pipe should be in 15mm pipe and incorporate a check valve to prevent backflow. A suitable WRAS approved bronze circulation pump will be required. On large systems, due to the increase in system water content, it may be necessary to fit an additional expansion vessel to the secondary circuit. This should be done if the capacity of the secondary circuit exceeds 10 litres.

Pipe capacity (copper):

15mm O.D. = 0.13 l/m (10 litres = 77m)

22mm O.D. = 0.38 l/m (10 litres = 26m)

28mm O.D. = 0.55 l/m (10 litres = 18m)

OUTLET

The hot water outlet is a 22mm compression fitting located at the top of the cylinder. Hot water distribution pipework should be 22mm pipe with short runs of 15mm pipe to terminal fittings such as sinks and basins. Pipe sizes may vary due to system design.

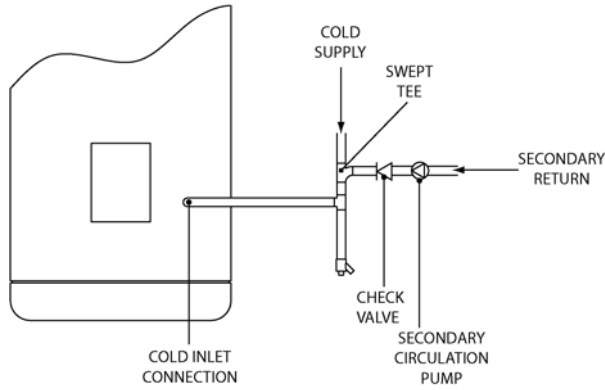

Fig. 3: Secondary circulation connection

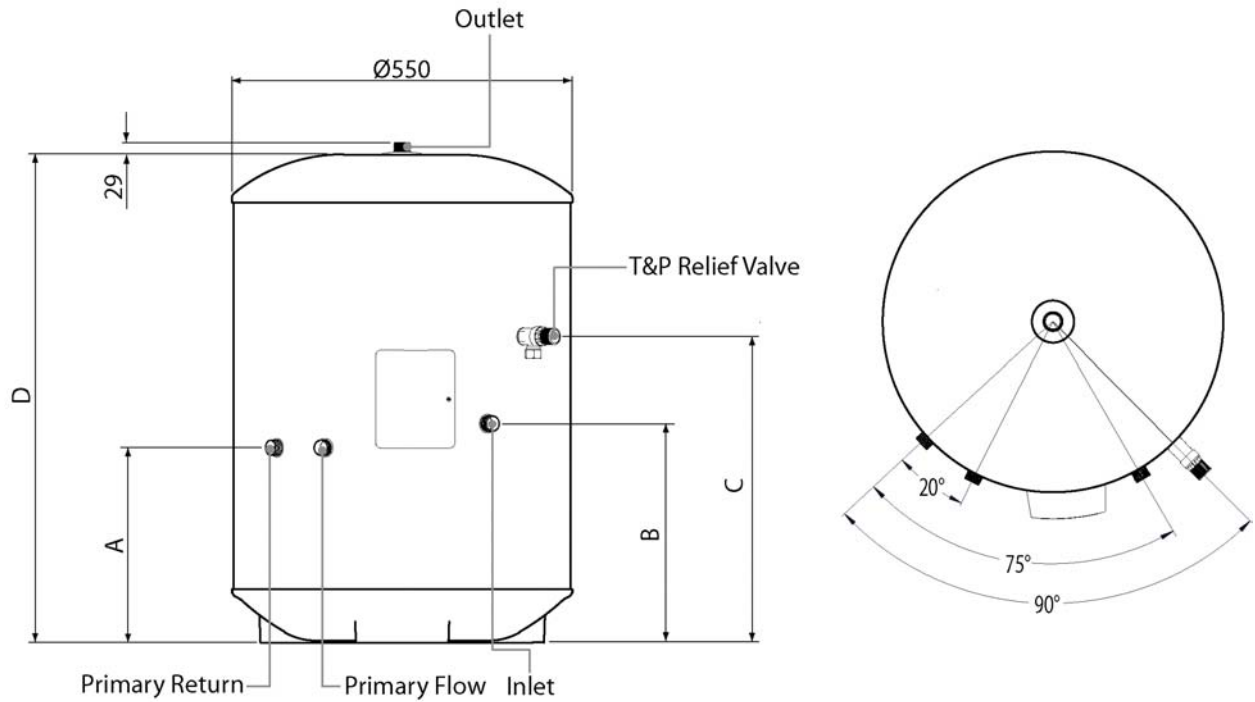

Fig. 4 General dimensions

NOMINAL CAPACITY (litres)	DIMENSIONS (mm)				COIL		HEATING TIME DIRECT (mins)
	A	B	C	D	RATING (kW)	RECOVERY (mins)	
120	315	364	615	906	12.5	23	110
150	315	364	800	1090	12.5	24	142
170	315	364	925	1216	16.0	25	163
210	315	364	1184	1474	16.0	29	205
250	315	364	1378	1731	18.0	30	252
300	315	364	1693	2045	19.0	35	304

Table 2: Dimensions and performance

Notes:

1. Recovery time based on heating 70% of capacity through 45°C.
2. Direct heating times assume use of lower element only, from cold, through 45°C.

DISCHARGE PIPEWORK

It is a requirement of Building Regulation G3 that any discharge from an unvented system is conveyed to where it is visible, but will not cause danger to persons in or about the building. The tundish and discharge pipes should be fitted in accordance with the requirements and guidance notes of Building Regulation G3. The G3 Requirements and Guidance section 3.9 are reproduced in the following sections of this manual. Information Sheet No.33 available from the British Board of Agrément gives further advice on discharge pipe installation. For discharge pipe arrangements not covered by G3 Guidance or BBA Info Sheet No.33 advice should be sought from your local Building Control Officer. Any discharge pipe connected to the pressure relief devices (Expansion Valve and Temperature/Pressure Relief Valve) must be installed in a continuously downward direction and in a frost free environment.

Water may drip from the discharge pipe of the pressure relief device. This pipe must be left open to the atmosphere. The pressure relief device is to be operated regularly to remove lime deposits and to verify that it is not blocked.

G3 REQUIREMENT

"...there shall be precautions...to ensure that the hot water discharged from safety devices is safely conveyed to where it is visible but will not cause danger to persons in or about the building."

G3 GUIDANCE SECTION 3.9

The discharge pipe (D1) [see fig. 5 in this instruction book] from the vessel up to and including the tundish is generally supplied by the manufacturer of the hot water storage system. Where otherwise, the installation should include the discharge pipe(s) (D1) from the safety device(s).

In either case the tundish should be vertical, located in the same space as the unvented hot water storage system and be fitted as close as possible and within 500mm of the safety device e.g. the temperature relief valve.

The discharge pipe (D2) from the tundish should terminate in a safe place where there is no risk to persons in the vicinity of the discharge, preferably be of metal and:

a. be at least one pipe size larger than the nominal outlet size of the safety device unless its total equivalent hydraulic resistance exceeds that of a straight pipe 9m long i.e. discharge pipes between 9m and 18m equivalent resistance length should be at least two sizes larger than the nominal outlet size of the safety device, between 18 and 27m at least 3 sizes larger, and so on. Bends must be taken into account in calculating the flow resistance. Refer to Table 3,

Table 1 and the worked example [see Table 3 and Fig. 5 in this instruction book].

An alternative approach for sizing discharge pipes would be to follow BS 6700:1987 Specification for design installation, testing and maintenance of services supplying water for domestic use within buildings and their curtilages, Appendix E, section E2 and table 21.

b. have a vertical section of pipe at least 300mm long, below the tundish before any elbows or bends in the pipework.

c. be installed with a continuous fall and in a frost free environment.

d. have discharges visible at both the tundish and the final point of discharge but where this is not possible or is practically difficult there should be clear visibility at one or other of these locations. Examples of acceptable discharge arrangements are:

i. ideally below a fixed grating and above the water seal in a trapped gully.

ii. downward discharges at low level; i.e. up to 100mm above external surfaces such as car parks, hard standings, grassed areas etc. are acceptable providing that where children may play or otherwise come into contact with discharges a wire cage or similar guard is positioned to prevent contact, whilst maintaining visibility.

iii. discharges at high level; e.g. into a metal hopper and metal down pipe with the end of the discharge pipe clearly visible (tundish visible or not) or onto a roof capable of withstanding high temperature discharges of water and 3m from any plastics guttering system that would collect such discharges (tundish visible).

iv. where a single pipe serves a number of discharges, such as in blocks of flats, the number served should be limited to not more than 6 systems so that any installation discharging can be traced reasonably easily. The single common discharge pipe should be at least one pipe size larger than the largest individual discharge pipe (D2) to be connected. If unvented hot water storage systems are installed where discharges from safety devices may not be apparent i.e. in dwellings occupied by blind, infirm or disabled people, consideration should be given to the installation of an electronically operated device to warn when discharge takes place.

Note: The discharge will consist of scalding water and steam. Asphalt, roofing felt and non-metallic rainwater goods may be damaged by such discharges.

Worked example of discharge pipe sizing

Fig. 5: shows a G1/2 temperature relief valve with a discharge pipe (D2) having 4 No. elbows and length of 7m from the tundish to the point of discharge.

From Table 3:

Maximum resistance allowed for a straight length of 22mm copper discharge pipe (D2) from a G1/2 temperature relief valve is 9.0m.

Subtract the resistance for 4 No. 22mm elbows at 0.8m each = 3.2m

Therefore the permitted length equates to: 5.8m

5.8m is less than the actual length of 7m therefore calculate the next largest size.

Maximum resistance allowed for a straight length of 28mm pipe (D2) from a G1/2 temperature relief valves equates to 18m.

Subtract the resistance of 4 No. 28mm elbows at 1.0m each = 4.0m

Therefore the maximum permitted length equates to: 14m

As the actual length is 7m, a 28mm (D2) copper pipe will be satisfactory.

WARNINGS:

- Under no circumstances should the factory fitted temperature/pressure relief valve be removed other than by a competent person. To do so will invalidate any guarantee or claim.
- The cold water combination valve assembly must be fitted on the mains water supply to the CENTERSTORE cylinder.
- No control or safety valves should be tampered with or used for any other purpose.
- The discharge pipe should not be blocked or used for any other purpose.
- The tundish should not be located adjacent to any electrical components.

VALVE OUTLET SIZE	MINIMUM SIZE OF DISCHARGE PIPE D1	MINIMUM SIZE OF DISCHARGE PIPE D2 FROM TUNDISH	MAXIMUM RESISTANCE ALLOWED, EXPRESSED AS A LENGTH OF STRAIGHT PIPE (I.E. NO ELBOWS OR BENDS)	RESISTANCE CREATED BY EACH ELBOW OR BEND
G 1/2	15MM	22mm 28mm 35mm	UP TO 9M UP TO 18M UP TO 27M	0.8M 1.0M 1.4M
G 3/4	22MM	28mm 35mm 42mm	UP TO 9M UP TO 18M UP TO 27M	1.0M 1.4M 1.7M
G 1	28MM	35mm 42mm 54mm	UP TO 9M UP TO 18M UP TO 27M	1.4M 1.7M 2.3M

Table 3: Sizing of copper discharge pipe (D2) for common temperature relief valve outlet sizes

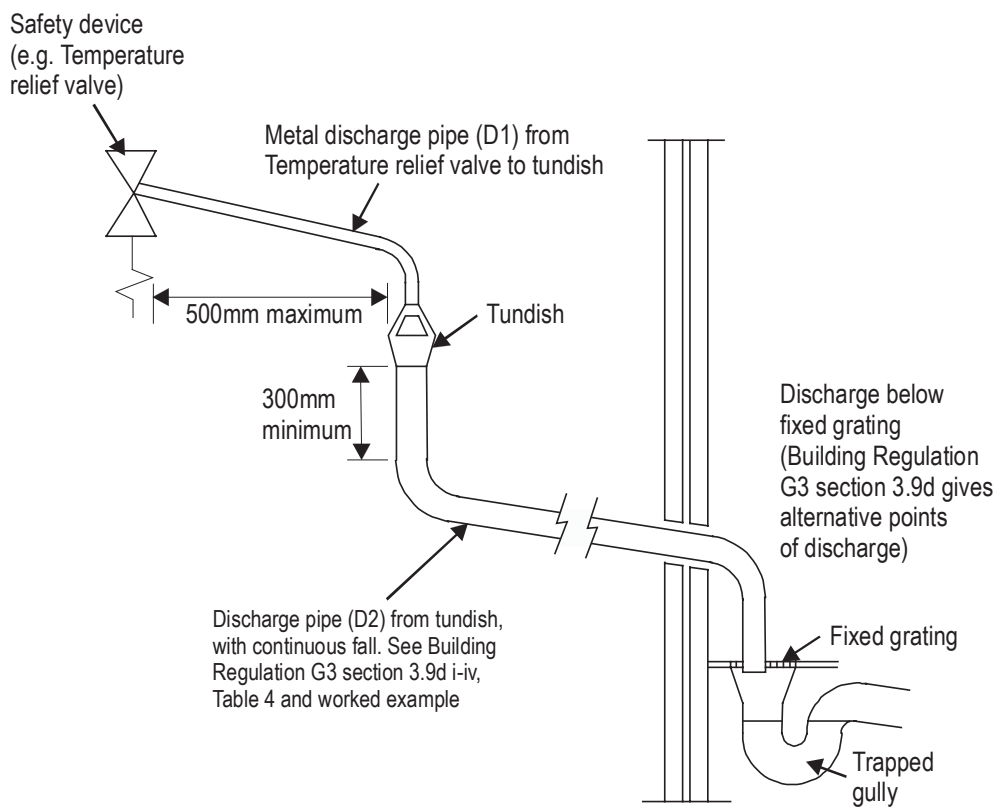

Fig. 5: Typical discharge pipe arrangement (extract from Building Regulation G3 Guidance section 3.9)

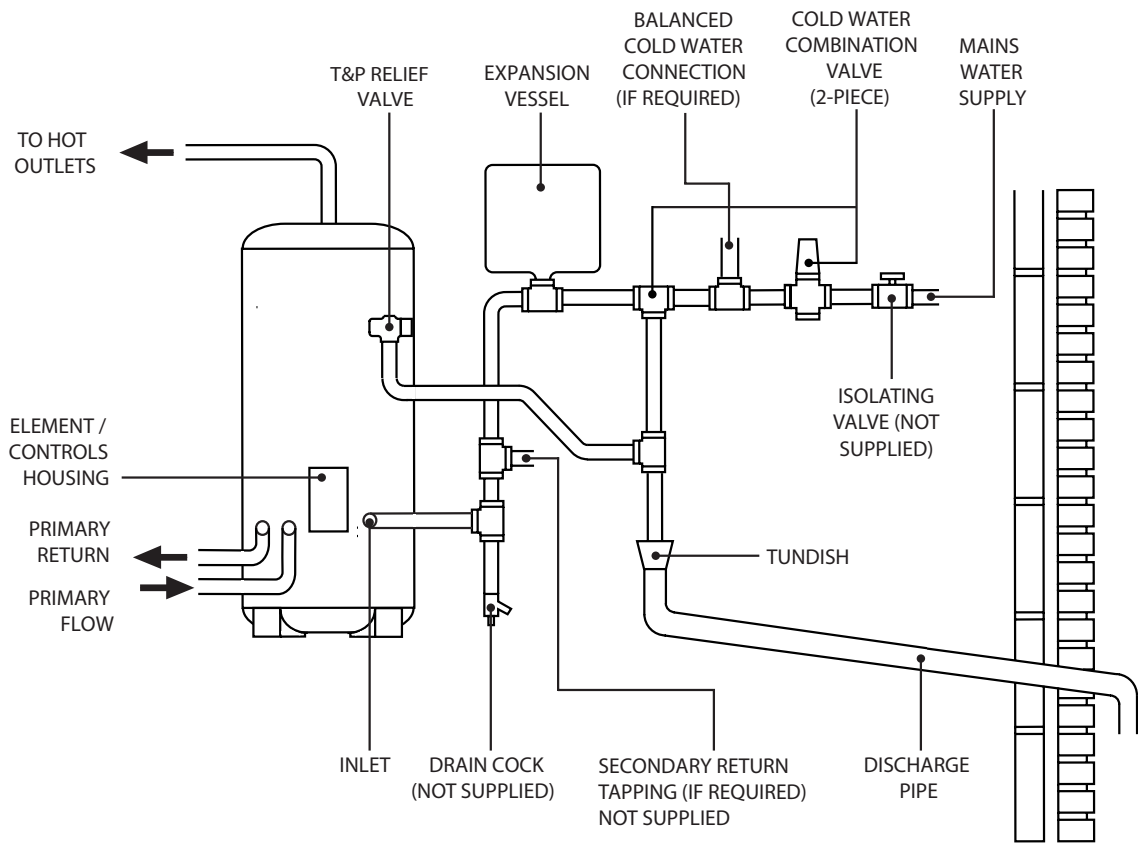

Fig. 6: Typical installation - schematic

ELECTRICAL CONNECTIONS

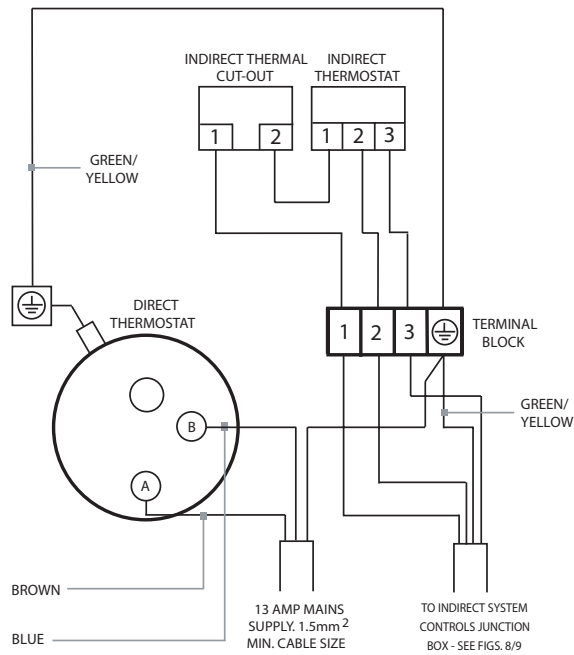

Fig. 7: Electrical connections (schematic)

INSTALLATION

PLUMBING CONNECTIONS

CENTERSTORE cylinders require the following pipework connections.

- Cold water supply to and from inlet controls.
- Outlet to hot water draw off points.
- Discharge pipework from valve outlets to tundish
- Connection to the primary circuit.

All connections are 22mm compression. However, 3/4" BSP parallel threaded fittings can be fitted to the primary coil connections if required.

ELECTRICAL SUPPLY (FIG. 7)

All units are fitted with a 3kW immersion heater and a combined thermostat and thermal cut-out to control the indirect heating source. **The CENTERSTORE cylinder MUST be earthed.**

All wiring to the unit must be installed in accordance with the latest IEE Wiring Regulations and the supply circuits must be protected by a suitable fuse and double pole isolating switch with a contact separation of at least 3mm in both poles. All connections are made to the terminal block located under the terminal cover mounted on the side of the unit. The supply cable(s) must be routed through the cable grip(s) in the terminal housing.

DISCONNECT FROM MAINS SUPPLY BEFORE REMOVING ANY COVERS. DO NOT BYPASS THE THERMAL CUT-OUTS IN ANY CIRCUMSTANCES.

Ensure the thermostat and thermal cut-out sensing bulbs are pushed fully into the pockets on the element plate assembly.

BOILER SELECTION

The boiler should have a control thermostat and non self-resetting thermal cut-out and be compatible with unvented storage water heaters.

Where use of a boiler without a thermal cut-out is unavoidable a "low head" open vented primary circuit should be used. The feed and expansion cistern head above the CENTERSTORE cylinder should not exceed 2.5m.

PRIMARY CIRCUIT CONTROL

The 2 port motorised valve supplied with the CENTERSTORE cylinder MUST be fitted on the primary flow to the CENTERSTORE cylinder heat exchanger and wired in series with the indirect thermostat and thermal cut-out fitted to the unit.

Primary circulation to the CENTERSTORE cylinder heat exchanger must be pumped; gravity circulation WILL NOT WORK.

SPACE AND HEATING SYSTEMS CONTROLS

The controls provided with the CENTERSTORE cylinder will ensure the safe operation of the unit within the central heating system. Other controls will be necessary to control the space heating requirements and times that the system is required to function. (See Fig. 7)

The CENTERSTORE cylinder is compatible with most heating controls, examples of electrical circuits are shown in Figs. 8 and 9. However, other systems may be suitable, refer to the controls manufacturers' instructions, supplied with the controls selected, for alternative system wiring schemes.

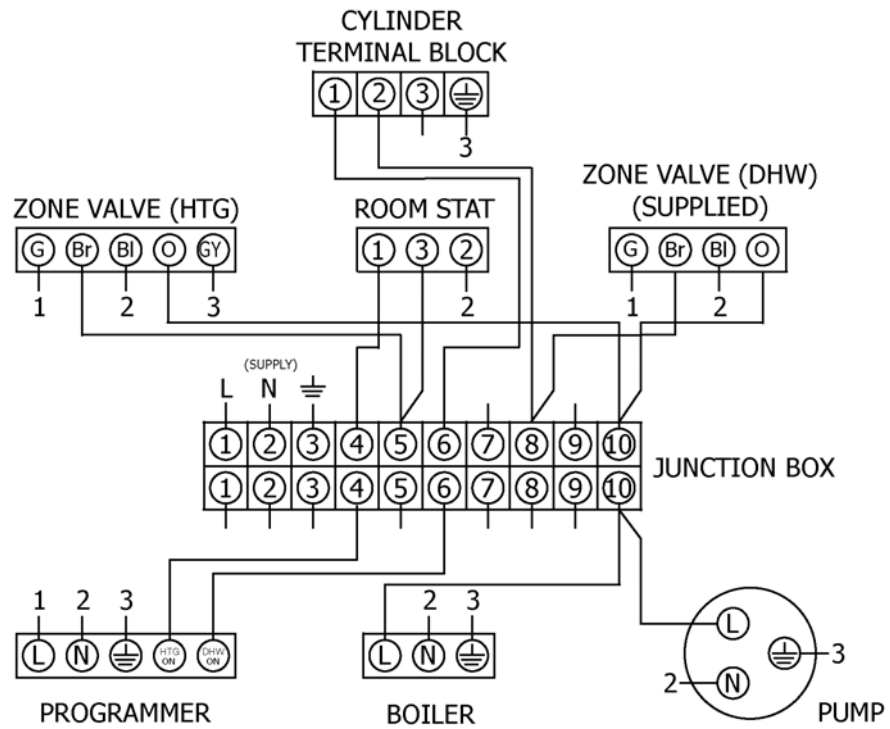

NOTES:
 CONTROL TERMINAL NUMBERING MAY DIFFER FROM THOSE SHOWN.
 REFER TO INSTRUCTIONS WITH CONTROLS SELECTED.
 A DOUBLE POLE ISOLATING SWITCH MUST BE INSTALLED IN THE MAINS SUPPLY.
 ALL EARTH CONNECTIONS MUST BE CONNECTED BACK TO THE MAINS EARTH SUPPLY.

Fig. 8: Schematic wiring diagram - Basic 2 x 2 port valve system

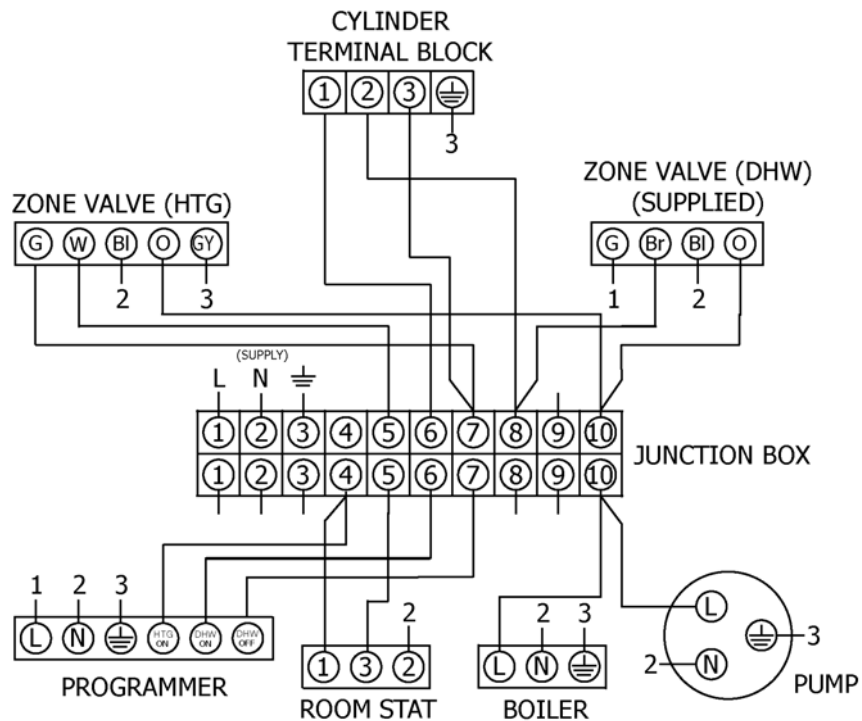

NOTES:
 CONTROL TERMINAL NUMBERING MAY DIFFER FROM THOSE SHOWN.
 REFER TO INSTRUCTIONS WITH CONTROLS SELECTED.
 A DOUBLE POLE ISOLATING SWITCH MUST BE INSTALLED IN THE MAINS SUPPLY.
 ALL EARTH CONNECTIONS MUST BE CONNECTED BACK TO THE MAINS EARTH SUPPLY.

Fig. 9: Schematic wiring diagram - 3 port mid position valve system. N.B. Must be used in conjunction with 2 port zone valve supplied

COMMISSIONING

At the time of commissioning, please ensure all relevant sections of the Benchmark Checklist, located on Page 17 and 18 of this document, are completed.

FILLING THE UNIT WITH WATER

- Check expansion vessel pre-charge pressure. The vessel is supplied precharged to 3.5 bar to match the control pressure of the pressure reducing valve. The precharge pressure is checked using a car tyre gauge by unscrewing the plastic cap opposite the water connection.
- Check all connections for tightness including the immersion heater(s). An immersion heater key spanner is supplied for this purpose.
- Ensure the drain cock is **CLOSED**.
- Open a hot tap furthest from the CENTERSTORE cylinder.
- Open the mains stop cock to fill the unit. When water flows from the tap, allow to run for a few minutes to thoroughly flush through any residue, dirt or swarf, then close the tap.
- Open successive hot taps to purge the system of air.

SYSTEM CHECKS

- Check all water connections for leaks and rectify as necessary.
- Turn off mains water supply.
- Remove the pressure reducing valve head work to access the strainer mesh, clean and re-fit.
- Manually open, for a few seconds, each relief valve in turn, checking that water is discharged and runs freely through the tundish and out at the discharge point.
- Ensure that the valve(s) reseal satisfactorily.

Fill the indirect (primary) circuit following the boiler manufacturer's commissioning instructions. To ensure the CENTERSTORE cylinder primary heat exchanger is filled, the 2 port motorised valve (supplied) should be manually opened by moving the lever on the motor housing to the MANUAL setting. When the primary circuit is full return the lever to the AUTOMATIC position. Switch on the boiler, ensure the programmer is set to Domestic Hot Water and allow the CENTERSTORE cylinder to heat up to a normal working temperature (60°C recommended, approximately graduation 4 on the thermostat). If necessary the temperature can be adjusted by inserting a flat bladed screwdriver in the adjustment knob (located on top of the thermostat mounting bracket - see Fig.10) and rotating. The minimum thermostat setting is 10°C.

The adjustment range 1 to 5 represents a temperature range of 30° to 70°C. Check the operation of the indirect thermostat and 2 port motorised valve and that no water has issued from the expansion relief valve or temperature/pressure relief valve during the heating cycle.

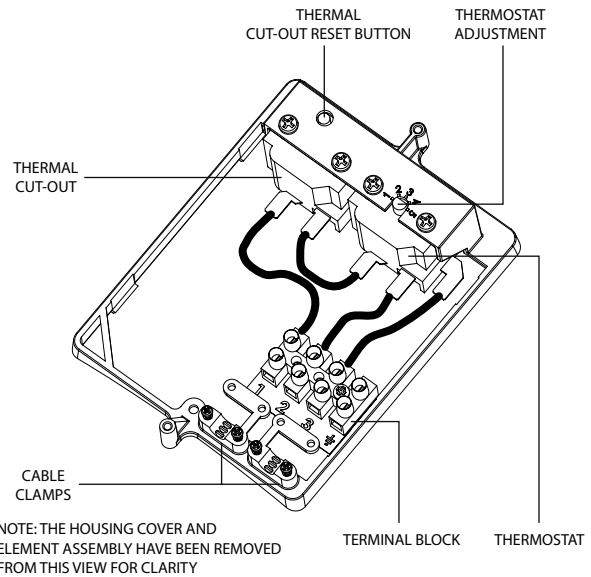

Fig. 10: Indirect thermostat and thermal cut-out

MAINTENANCE

MAINTENANCE REQUIREMENTS

Unvented hot water systems have a continuing maintenance requirement in order to ensure safe working and optimum performance. It is essential that the relief valve(s) are periodically inspected and manually opened to ensure no blockage has occurred in the valves or discharge pipework. Similarly cleaning of the strainer element and replacement of the air in the expansion vessel will help to prevent possible operational faults.

The maintenance checks described below should be performed by a competent person on a regular basis, e.g. annually to coincide with boiler maintenance.

After any maintenance, please complete the relevant Service Interval Record section of the Benchmark Checklist located on Page 17 and 18 of this document.

SAFETY VALVE OPERATION

Manually operate the temperature/pressure relief valve for a few seconds. Check water is discharged and that it flows freely through the tundish and discharge pipework. Check valve reseats correctly when released. **NOTE: Water discharged may be very hot!**

Repeat the above procedure for the Expansion Valve.

STRAINER

Turn off the cold water supply, boiler and immersion heaters. The lowest hot water tap should then be opened to de-pressurise the system. Remove the pressure reducing cartridge to access the strainer mesh. Wash any particulate matter from the strainer under clean water. Re-assemble ensuring the seal is correctly fitted. DO NOT use any other type of sealant.

DESCALING IMMERSION HEATER(S)

Before removing the immersion heater(s) the unit must be drained. **Ensure the water, electrical supply and boiler are OFF before draining.** Attach a hosepipe to the drain cock having sufficient length to take water to a suitable discharge point below the level of the unit. Open a hot tap close to the unit and open drain cock to drain unit.

Open the cover(s) to the immersion heater housing(s) and disconnect wiring from immersion heater(s) thermostat(s). Remove thermostat by carefully pulling outwards. Remove thermostat capillary sensors from the pockets on the immersion heater. Unscrew immersion heater backnut(s) and remove immersion heater from the unit. A key spanner is supplied with the CENTERSTORE cylinder unit for easy removal/tightening of the immersion heater(s). Over time the immersion heater gasket may become stuck to the mating surface. To break the seal insert a round bladed screwdriver into one of the pockets on the immersion heater and gently lever up and down.

Carefully remove any scale from the surface of the element(s). DO NOT use a sharp implement as damage to the element surface could be caused. Ensure sealing surfaces are clean and seals are undamaged, if in doubt fit a new gasket (part number 95 611 822).

Replace immersion heater(s) ensuring the lower (right angled) element hangs vertically downwards towards the base of the unit. It may be helpful to support the immersion heater using a round bladed screwdriver inserted into one of the thermostat pockets whilst the backnut is tightened. Replace thermostat capillaries into pocket. Replace the immersion heater thermostat by carefully plugging the two male spade terminations on the underside of the thermostat head into the corresponding terminations on the element. Rewire, check, close and secure immersion heater housing cover(s).

EXPANSION VESSEL CHARGE PRESSURE

Remove the dust cap on top of the vessel. Check the charge pressure using a tyre pressure gauge. The pressure (with system de-pressurised) should be 3.5 bar. If it is lower than the required setting it should be re-charged using a tyre pump (Schrader valve type). DO NOT OVER-CHARGE. Re-check the pressure and when correct replace the dust cap.

RE-COMMISSIONING

Check all electrical and plumbing connections are secure. Close the drain cock. With a hot tap open, turn on the cold water supply and allow unit to refill. DO NOT switch on the immersion heater(s) or boiler until the unit is full. When water flows from the hot tap allow to flow for a short while to purge air and flush through any disturbed particles. Close hot tap and then open successive hot taps in system to purge any air.

When completely full and purged check system for leaks. The heating source (immersion heater(s) or boiler) can then be switched on.

USER INSTRUCTIONS

WARNINGS

IF WATER ISSUES FROM THE TEMPERATURE/PRESSURE RELIEF VALVE ON THE CENTERSTORE CYLINDER SHUT DOWN THE BOILER. DO NOT TURN OFF ANY WATER SUPPLY. CONTACT A COMPETENT INSTALLER FOR UNVENTED WATER HEATERS TO CHECK THE SYSTEM.

DO NOT TAMPER WITH ANY OF THE SAFETY VALVES FITTED TO THE CENTERSTORE SYSTEM. IF A FAULT IS SUSPECTED CONTACT A COMPETENT INSTALLER.

BENCHMARK

CENTERSTORE, is a licensed member of the Benchmark Scheme which aims to improve the standards of installation and commissioning of domestic heating and hot water systems in the UK and to encourage regular servicing to optimise safety, efficiency and performance.

Benchmark is managed and promoted by the Heating and Hotwater Industry Council. For more information visit www.centralheating.co.uk.

Please ensure that the installer has fully completed the Benchmark Checklist on Page 17 and 18 of this manual and that you have signed it to say that you have received a full and clear explanation of its operation. The installer is legally required to complete a commissioning checklist as a means of complying with the appropriate Building Regulations (England and Wales).

All installations must be notified to Local Area Building Control either directly or through a Competent Persons Scheme. A Building Regulations Compliance Certificate will then be issued to the customer who should, on receipt, write the Notification Number on the Benchmark Checklist.

This product should be serviced regularly to

optimise its safety, efficiency and performance. The service engineer should complete the relevant Service Record on the Benchmark Checklist after each service.

The Benchmark Checklist may be required in the event of any warranty work and as supporting documentation relating to home improvements in the optional documents section of the Home Improvements Pack.

TEMPERATURE CONTROLS (Fig. 7)

The CENTERSTORE cylinder units are fitted with an indirect thermostat and thermal cut-out. These controls must be wired in series with the 2 port motorised zone valve supplied to interrupt the flow of primary water around the heat exchanger coil when the control temperature has been reached. The controls are located within the lower terminal housing along with the immersion heater thermostat. The thermostat is factory set to give a water storage temperature of approx. 55° to 60°C. Access to the thermostat can be made by opening the terminal housing cover - **DISCONNECT THE ELECTRICAL SUPPLY BEFORE OPENING THE COVER.** Temperature adjustment is made by inserting a flat bladed screwdriver in the adjustment knob and rotating. The minimum thermostat setting is 10°C. The adjustment range 1 to 5 represents a temperature range of 30° to 70°C (60°C will be approximately position 4). If in any doubt contact a competent electrician.

An immersion heater is also provided for use should the indirect heat source be shut down for any purpose. The immersion heater control temperature is set using the immersion heater thermostat.

DO NOT bypass the thermal cut-out(s) in any circumstances.

FLOW PERFORMANCE

When initially opening hot outlets a small surge in flow may be noticed as pressures stabilise. This is quite normal with unvented systems. In some areas cloudiness may be noticed in the hot water. This is due to aeration of the water, is quite normal and will quickly clear.

OPERATIONAL FAULTS

Operational faults and their possible causes are detailed in the Fault Finding section of this book. It is recommended that faults should be checked by a competent installer.

The air volume within the expansion vessel will periodically require recharging to ensure expanded water is accommodated within the unit.

A discharge of water **INTERMITTENTLY** from the expansion valve will indicate the air volume has reduced to a point where it can no longer accommodate the expansion.

FAULT FINDING & SERVICING

IMPORTANT

- After servicing, complete the relevant Service Interval Record section of the Benchmark Checklist located on page 17 and 18 of this document.
- Servicing should only be carried out by competent persons in the installation and maintenance of unvented water heating systems.
- Any spare parts used **MUST** be authorised CENTERSTORE parts.
- Disconnect the electrical supply before removing any electrical equipment covers.
- **NEVER** bypass any thermal controls or operate system without the necessary safety valves.
- Water contained in the CENTERSTORE cylinder may be very hot, especially following a thermal control failure. Caution must be taken when drawing water from the unit.

SPARE PARTS

A full range of spare parts are available for the CENTERSTORE cylinder range (See Table 4). Refer to the technical data label on the unit to identify the model installed and ensure the correct part is ordered. You will need to quote the serial number and the guarantee code, which are printed on the data label.

FAULT FINDING

The fault finding chart on page 16 will enable operational faults to be identified and their possible causes rectified. Any work carried out on the CENTERSTORE cylinder unvented water heater and its associated controls **MUST** be carried out by a competent installer for unvented water heating systems. In case of doubt contact service support (see contact details on back page).

WARNING

DO NOT TAMPER WITH ANY OF THE SAFETY VALVES OR CONTROLS SUPPLIED WITH THE CENTERSTORE CYLINDER AS THIS WILL INVALIDATE ANY GUARANTEE

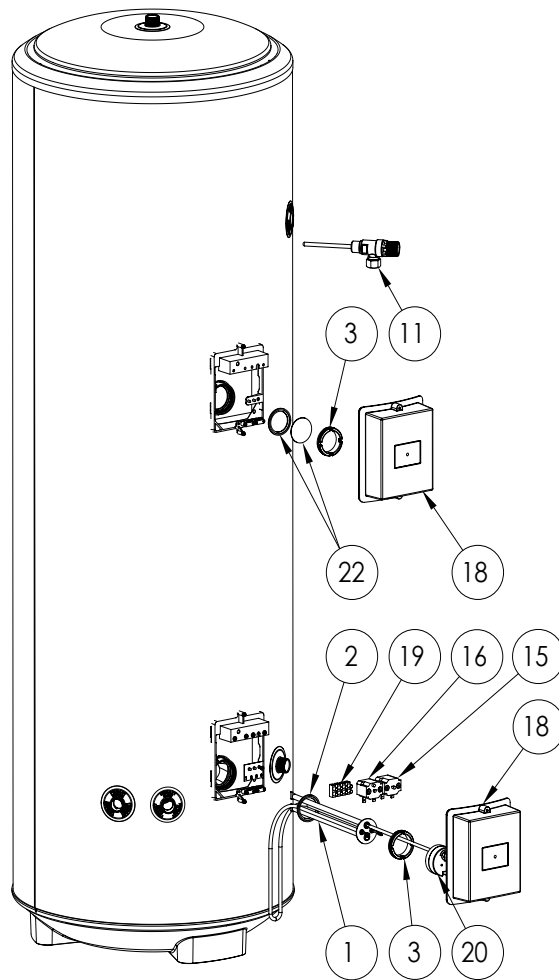

Fig. 11: Spares Diagram

	Description	Part No.
1	Immersion heater	95 606 961
2	Immersion heater gasket	95 611 822
3	Immersion heater backnut	95 607 869
4	Immersion heater key spanner	95 607 861
5	Tundish	95 605 838
6	Expansion valve cartridge - 6bar	95 605 864
7	Expansion valve complete - 6bar	95 607 030
8	Cold water combination valve complete	95 605 047
9	Cold water combination valve body	95 605 048
10	Pressure reducing valve cartridge 3.5bar	95 607 029
11	Temperature/Pressure Relief Valve	95 605 810
12	Expansion vessel 12 litre (120 and 150 litre models)	95 607 863
13	Expansion vessel 18 litre (170 and 210 litre models)	95 607 864
14	Expansion vessel 24 litre (250 and 300 litre models)	95 607 612
15	Indirect thermostat	95 612 697
16	Indirect thermal cut-out	95 612 698
17	Motorised valve 2 port	95 605 049
18	Terminal cover	95 614 094
19	4 Way terminal block	95 607 902
20	Combined thermostat and thermal cut out	95 612 026
21	Accessory kit (indirect and without expansion vessel)	95 607 968
22	Blanking Plate Assembly	95 607 064

Table 4: Spares

FAULT	POSSIBLE CAUSE	REMEDY
No hot water flow	1. Mains supply off.	1. Check and open stop cock.
	2. Strainer blocked.	2. Turn off water supply. Remove strainer and clean (see Maintenance section).
	3. Cold Water Combination Valve incorrectly fitted.	3. Check and refit as required.
Water from hot taps is cold	1. BACK UP immersion heater not switched on.	1. Check and switch on.
	2. BACK UP immersion heater thermal cut-out has operated.	2. Check. Reset by pushing button.
	3. INDIRECT programmer set to Central Heating only.	3. Check. Set to a Domestic Hot Water programme.
	4. INDIRECT boiler not working.	4. Check boiler operation. If fault is suspected consult boiler manufacturer's instructions.
	5. INDIRECT thermal cut-out has operated.	5. Check. Reset by pushing button on cut-out. Check operation of indirect thermostat.
	6. INDIRECT motorised valve not connected correctly.	6. Check wiring and/or plumbing connections to motorised valve (see Fig. 7).
Water discharges from Expansion Valve	1. INTERMITTENTLY Expansion Vessel charge pressure has reduced below 3.5bar.	1. See Maintenance section for re-charging procedure.
	2. CONTINUALLY a. Cold Water Combination Valve Pressure Reducer not working correctly. b. Expansion Valve seat damaged.	2a. Check pressure from Cold Water Combination Valve. If greater than 3.5bar replace Pressure Reducer cartridge. 2b. Remove Expansion Valve cartridge. Check condition of seat. If necessary fit new Expansion Valve cartridge.
Water discharges from T&P Relief Valve	1. Thermal control failure NOTE water will be very hot.	1. Switch off power to immersion heater(s) and shut down boiler. DO NOT turn off water supply. When discharge stops check all thermal controls, replace if faulty.
Milky water	1. Oxygenated water.	1. Water from a pressurised system releases oxygen bubbles when flowing. The milkiness will disappear after a short while.

Table 5: Fault finding chart

OTHER INFORMATION

Nominal Capacity (litres)	Standing Heat Loss	
	per day (kWh/24h)	per year (kWh/365d)
120	1.47	537
150	1.70	621
170	1.92	701
210	2.10	767
250	2.22	811
300	2.52	920

Table 6: Standing heat losses (based on an ambient air temperature of 20°C and a stored water temperature of 65°C)

ENVIRONMENTAL INFORMATION

CENTERSTORE products are manufactured from many recyclable materials. At the end of their useful life they should be disposed of at a Local Authority Recycling Centre in order to realise the full environmental benefits.

Insulation is by means of an approved CFC/HCFC free polyurethane foam with an ozone depletion factor of zero.

While the following Checklist can be used for any installation covered by its description, only appliances manufactured by Scheme Members will be covered by the rules and requirements of the Benchmark Scheme.

MAINS PRESSURE HOT WATER STORAGE SYSTEM COMMISSIONING CHECKLIST

This Commissioning Checklist is to be completed in full by the competent person who commissioned the storage system as a means of demonstrating compliance with the appropriate Building Regulations and then handed to the customer to keep for future reference.

Failure to install and commission this equipment to the manufacturer's instructions may invalidate the warranty but does not affect statutory rights.

Customer Name _____ Telephone Number _____
Address _____
Cylinder Make and Model _____
Cylinder Serial Number _____
Commissioned by (print name) _____ Registered Operative ID Number _____
Company Name _____ Telephone Number _____
Company Address _____
Commissioning Date _____

To be completed by the customer on receipt of a Building Regulations Compliance Certificate*:

Building Regulations Notification Number (if applicable) _____

ALL SYSTEMS PRIMARY SETTINGS (indirect heating only)

Is the primary circuit a sealed or open vented system? Sealed Open
What is the maximum primary flow temperature? _____ °C

ALL SYSTEMS

What is the incoming static cold water pressure at the inlet to the system? _____ bar
Has a strainer been cleaned of installation debris (if fitted)? Yes No
Is the installation in a hard water area (above 200ppm)? Yes No
If yes, has a water scale reducer been fitted? Yes No
What type of scale reducer has been fitted? _____
What is the hot water thermostat set temperature? _____ °C
What is the maximum hot water flow rate at set thermostat temperature (measured at high flow outlet)? _____ l/min
Time and temperature controls have been fitted in compliance with Part L of the Building Regulations? Yes
Type of control system (if applicable) Y Plan S Plan Other
Is the cylinder solar (or other renewable) compatible? Yes No
What is the hot water temperature at the nearest outlet? _____ °C
All appropriate pipes have been insulated up to 1 metre or the point where they become concealed Yes

UNVENTED SYSTEMS ONLY

Where is the pressure reducing valve situated (if fitted)? _____
What is the pressure reducing valve setting? _____ bar
Has a combined temperature and pressure relief valve and expansion valve been fitted and discharge tested? Yes No
The tundish and discharge pipework have been connected and terminated to Part G of the Building Regulations Yes
Are all energy sources fitted with a cut out device? Yes No
Has the expansion vessel or internal air space been checked? Yes No

THERMAL STORES ONLY

What store temperature is achievable? _____ °C
What is the maximum hot water temperature? _____ °C

ALL INSTALLATIONS

The hot water system complies with the appropriate Building Regulations Yes
The system has been installed and commissioned in accordance with the manufacturer's instructions Yes
The system controls have been demonstrated to and understood by the customer Yes
The manufacturer's literature, including Benchmark Checklist and Service Record, has been explained and left with the customer Yes

Commissioning Engineer's Signature _____

Customer's Signature _____
(To confirm satisfactory demonstration and receipt of manufacturer's literature)

*All installations in England and Wales must be notified to Local Authority Building Control (LABC) either directly or through a Competent Persons Scheme. A Building Regulations Compliance Certificate will then be issued to the customer.



SERVICE RECORD

It is recommended that your hot water system is serviced regularly and that the appropriate Service Record is completed.

Service Provider

Before completing the appropriate Service Record below, please ensure you have carried out the service as described in the manufacturer's instructions.

SERVICE 1 Date _____

Engineer Name _____

Company Name _____

Telephone Number _____

Comments _____

Signature _____

SERVICE 2 Date _____

Engineer Name _____

Company Name _____

Telephone Number _____

Comments _____

Signature _____

SERVICE 3 Date _____

Engineer Name _____

Company Name _____

Telephone Number _____

Comments _____

Signature _____

SERVICE 4 Date _____

Engineer Name _____

Company Name _____

Telephone Number _____

Comments _____

Signature _____

SERVICE 5 Date _____

Engineer Name _____

Company Name _____

Telephone Number _____

Comments _____

Signature _____

SERVICE 6 Date _____

Engineer Name _____

Company Name _____

Telephone Number _____

Comments _____

Signature _____

SERVICE 7 Date _____

Engineer Name _____

Company Name _____

Telephone Number _____

Comments _____

Signature _____

SERVICE 8 Date _____

Engineer Name _____

Company Name _____

Telephone Number _____

Comments _____

Signature _____

SERVICE 9 Date _____

Engineer Name _____

Company Name _____

Telephone Number _____

Comments _____

Signature _____

SERVICE 10 Date _____

Engineer Name _____

Company Name _____

Telephone Number _____

Comments _____

Signature _____

GUARANTEE

The CENTERSTORE stainless steel vessel carries a full 25 year parts guarantee against faulty manufacture or materials provided that:

- It has been correctly installed as per the instructions contained in the instruction manual and all relevant Codes of Practice and Regulations in force at the time of installation.
- The Benchmark Checklist has been completed upon commissioning and the Benchmark Service Record is completed for each service.
- It has not been modified in any way, other than by CENTERSTORE.
- It has not been frost damaged.
- It has only been used for the storage of potable water.
- It has not been tampered with or been subjected to misuse or neglect.
- The damage is not scale related.
- Within 60 days of installation the user completes and returns the certificate supplied along with the proof of purchase to register the product.
- It has been installed in the United Kingdom.

The expansion vessel is guaranteed for a period of 2 years from the date of purchase. The CENTERSTORE components, immersion heater and thermal controls are guaranteed for a period of 2 years from the date of purchase. Evidence of purchase and date of supply may be required. The unit is not guaranteed against damage due to frost. The guarantee is transferable. This guarantee does not affect your statutory rights.

TECHNICAL SUPPORT & SPARES

For all technical support, replacement parts and service issues please contact:

CENTERSTORE
Brooks House,
Coventry Road,
Warwick,
CV34 4LL

Tel: 0844 871 1532

The policy of CENTERSTORE is one of continuous product development and, as such, we reserve the right to change specifications and guarantee terms and conditions without notice.