

D142

PN32

Bronze Swing Check Valve

Check valves permit flow in one direction only, and close automatically if flow reverses. They are entirely automatic in action, depending upon pressure and velocity of flow within the line to perform their functions of opening and closing.

The Crane D142 bronze check valve is of the swing variety.

Materials

PART	MATERIAL
Body	Bronze BS EN 1982 CC491K
Cap	Bronze BS EN 1982 CC491K
Cap	Brass BS EN 12164 CW721R
Disc	Bronze BS EN 1982 CC491K
Disc	Brass BS EN 12164 CW614N
Disc	Brass BS EN 12164 CW614N
Hinge Nut	Brass BS 2874 CZ121
Hinge Pin/Plug	Stainless Steel
Hinge	Bronze BS EN 1982 CC491K
Drive Pin	Steel-Electro Brassed
ID Plate	Aluminium



D142

Dimensional Drawing

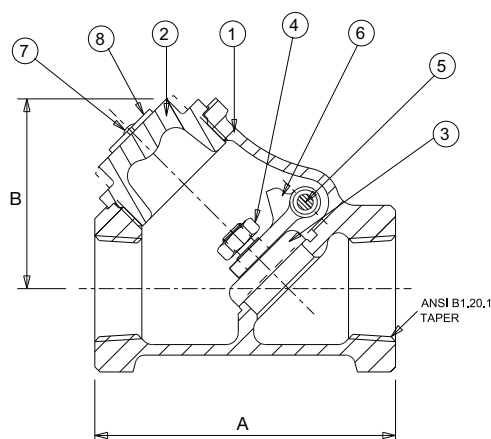

Dimensions & Weights

SIZE (inch)	WEIGHT (kg)	A (mm)	B (mm)
1/4	0.26	54	37
3/8	0.25	54	37
1/2	0.39	62	43
3/4	0.62	76	52
1	1.07	94	65
1 1/4	1.65	110	76
1 1/2	2.56	126	89
2	4.05	152	108
2 1/2	6.4	186	134
3	9.3	218	160

PRESSURE RATING: PN32

TEMPERATURE OPERATING RANGE: -10 to 260°C

UK END CONNECTION: BS 21 Taper

OPERATOR: Swing Check, Screwed in Cap. Can be mounted vertically as long as flow is upwards

SPECIFICATION: Valves are manufactured in accordance with BS 5154 for Series A ratings.

Design is of the Y-Pattern having flat regrindable swing disc and integral regrindable body seat. The disc is retained on the hinge by a locked nut and is free to swivel. The hinge pin is retained by an external threaded plug.

Valves having ANSI threads also generally conform to MSS SP-80.

This valve is not suitable for use on group 1 gases or unstable fluids, as defined by the Pressure Equipment Directive 97/23/EC.

Every effort has been made to ensure that the information contained in this publication is accurate at the time of publishing. Crane Ltd assumes no responsibility or liability for typographical errors or omissions or for any misinterpretation of the information within the publication and reserves the right to change without notice.