

customer/technical services

For any technical or installation queries please contact Vado on 01934 745163.

guarantee

This product is guaranteed against manufacturing defects from the date of purchase until the expiry of the relevant guarantee period shown below.

The guarantee is only valid if:-

1. The product has been installed, used and maintained in accordance with Vado's instructions and subjected to normal use only.
2. The defect is not due to use of an unsuitable or inadequate water or power supply.
3. The defect is not due to accident, misuse, neglect or repair other than by Vado or Vado authorised agents or damage caused by foreign objects or substances.
4. We have received from you the completed Guarantee Registration Form. Vado accepts no responsibility for any forms lost in the post and returns by registered means is therefore recommended.

Under this guarantee (which is non-transferable) Vado will, at its option, repair or replace free of charge any product (or replacement part) found to be defective. The guarantee does not extend to any consequential loss or damage. After repair or replacement the relevant guarantee period will be calculated from the original date of purchase.

The relevant guarantee periods are:-

1. Twelve years on chrome finish products.
2. Three years on all other products with the exception of Stuart Turner Pumps which carry a 2 year Guarantee on Monsoon Range and 1 Year Guarantee on Showermate Range.

All claims under the guarantee must be submitted in writing to the person who supplied the product to you and must be received no later than the last day of the relevant guarantee period. All claims must be accompanied by proof of purchase (sales receipt or delivery note).

Vado operates a policy of continuous product development and therefore reserves the right to change the product, packaging and documentation specifications without notice.

This guarantee is in addition to and does not affect your statutory rights as a consumer.

Vado

Wedmore Road, Cheddar, Somerset, England BS27 3EB
tel 01934 744466. fax 01934 744345
technical@vado-uk.com
www.vado-uk.com

GUARANTEE REGISTRATION

NAME				
ADDRESS				
	POSTCODE			
RETAILER				
ADDRESS				
	POSTCODE			
PURCHASE DATE	ARTICLE NUMBER	(SEE BOX)		
PRODUCT DESCRIPTION				
WHO INSTALLED THE PRODUCT?	RETAILER	PLUMBER	BUILDER	SELF
FOR VADO USE				



installation & maintenance instructions

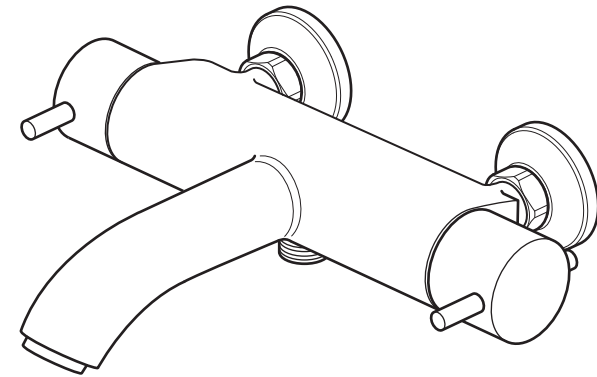

celsius

exposed thermostatic bath shower mixer

please leave these instructions with the customer

important - please read

Please read these instructions carefully before starting installation and keep for future reference.

Remove all packaging and check the product for missing parts or damage before starting installation.

Any alterations made to this product and fittings may infringe water regulations and will invalidate the guarantee.

The installation must comply with all Local/National Water Supply Authority Regulations/Byelaws and Building and Plumbing (UK:BS6700) Regulations.

We strongly recommend that you use a qualified and registered plumber.

IMPORTANT: Failure to comply with the installation and commissioning instructions as detailed will invalidate the product warranty.

general installation

Thermostatic Valves

The thermostatic mixing valve Vado CEL-123T has been specifically designed and manufactured to meet the requirements of BS EN1111 The valve has been independently tested and approved as a TYPE 2 valve under the TMV2 scheme.

This mixer valve is suitable for any water system. Where instantaneous heaters are used, the flow of hot water sufficient to start and go on burning must reach the minimum flow required – as specified by the heater manufacturer.

These fittings are mixing devices and therefore water supplies must be reasonably balanced.

Where connections are made to the mains cold water supply, WRAS approved single check valves must be fitted to both hot and cold inlets. This is a stated requirement of Water Supply (Water Fittings) Regulations 1999 Schedule 2, Section 6 G15.13.2

Before making any inlet pipe connections, all supply pipes MUST be thoroughly flushed to remove debris. Failure to do so could result in damage or low flow from the mixer unit. Water Supply (Water Fittings) Regulations 1999 Schedule 2 Section 4 G13.1

Isolating valves must be fitted to the inlet feeds for ease of maintenance.

The fitting of strainers is recommended.

Please take great care when installing this mixer not to damage its surface.

Operating pressures (on hot and cold line) should be kept as balanced as possible in order to assure optimum efficiency.

Note: When pressure is higher than 5 bar a pressure reducer is required to be fitted before the valve.

Please note if installing in an enclosed environment, access should be left for servicing and maintenance. No costs relating to inadequate access can be accepted.

maintenance - continued

5. Reassemble the cartridge into the body aligning up the hole in the cartridge with the grub screw, then place the plastic stop ring onto the cartridge with the stop at the 12 o'clock position.

6. Make sure everything is tight and secure and turn on the water supply at the isolating valves.

7. Now check the water temperature to ensure you are happy with it.

8. Ensure that the stop on the stop ring is at 12 o'clock and replace the handle with the temperature override button also pointing at 12 o'clock being careful not to turn the spline of the valve.

9. Secure the handle and replace the lever.

care of the mixer

Our products are finished to the highest standard and due care needs to be taken to ensure their looks are retained.

We recommend cleaning all products with a soft damp cloth ONLY and advise strongly against the use of ALL cleaning products i.e. powders and liquids.

If the above instructions are not followed this will invalidate your guarantee in the event of a problem occurring.

After cleaning, reassemble the Vado CEL-123T Valve. Exercise, reset and test the valve as laid out in the commissioning section.

maintenance

It is a requirement that all TMV2 approved valves shall be verified against the original set temperature results once a year. When commissioning/testing is due the following performance checks shall be carried out.

Measure the mixed water temperature at the outlet.

Carry out the cold water supply isolation test by isolating the cold water supply to the TMV, wait for five seconds if water is still flowing check that the temperature is below 46°C.

If there is no significant change to the set outlet temperature ($\pm 2^{\circ}\text{C}$ or less change from the original settings) and the fail-safe shut off is functioning, then the valve is working correctly and no further service work is required.

Notes.

If there is a residual flow during the commissioning or the annual verification (cold water supply isolation test), then this is acceptable providing the temperature of the water seeping from the valve is no more than 2°C above the designated maximum mixed water outlet temperature setting of the valve.

Temperature readings should be taken at the normal flow rate after allowing for the system to stabilise.

The sensing part of the thermometer probe must be fully submerged in the water that is to be tested.

Any TMV that has been adjusted or serviced must be re-commissioned and re-tested in accordance with these, instructions.

Filters.

This thermostatic valve is fitted with a double filtering facility. Filters are fitted on the water inlets and on the thermostatic cartridge.

Depending on the water quality, filters may become dirty, causing reduced flow and inefficient working of the valve.

Shut off the water supply to both inlets at the isolating valves.

Inlet Filters.

Undo both locking nuts at the back of the valve and remove from the wall. Pull out the filter/washer, rinse in water to remove the dirt, and then soak them in vinegar or descaling agent.

Cartridge Filters.

To clean the filters, you must first remove the cartridge from the housing.

Removing the Cartridge

1. Remove the handle (see temperature resetting).
2. Unscrew the grubscrew on the underside of the body and pull out the cartridge.
3. Clean the filters by rinsing them in water to remove the dirt and soaking them in vinegar or descaling agent.
4. Before reassembling the cartridge, clean its housing with a wet cloth and grease the 'O' rings on the cartridge.

general installation

Working Parameters And Technical Specification

Factory Temperature Setting	38° C
Temperature Setting Range	35° C to 46° C
Temperature (Hot Supply)	55° C to 65° C
Temperature (Cold Supply)	5° C to 25° C
Minimum Hot To Mix Differential Temperature	10° C
Temperature Stability	$\pm 2^{\circ}\text{C}$
Working Pressure, Static	10 Bar Max
Working Pressure, Dynamic High Pressure	0.5–5 Bar
Maximum Pressure Loss Ratio	10:1
Flow Rate Minimum	4 L/MIN
Flow Rate @ 1 Bar Pressure Loss	21 L/MIN

NOTES: Designations of use in table, refer to HP-S and HP-T.

Valves operating outside these conditions cannot be guaranteed by the Scheme to operate as Type 2 valves.

If water supply is fed by gravity then supply pressure should be verified to ensure the conditions of use are appropriate for the valve.

Approvals & Application

Building Cert Approval Number BC558

The thermostatic mixing valve Vado CEL-123T has been independently tested by WRC and certified by Buildcert as meeting the requirements of the BS EN1111 specification under the TMV2 scheme as being suitable for use on the following designations.

Code	Operating Pressure	Application
HP-S	High Pressure	Shower – temperature 41° C
HP-T	High Pressure	Tub/Bath – temperature 46° C

operating specifications

Hot Water Supply Temperature:

Maximum: 80° C

Minimum: 10° C higher than the maximum required mixed temperature (advise 65° C)

Dynamic Pressure

Maximum: 5 bar

Minimum: 1.5 bar

flow rate

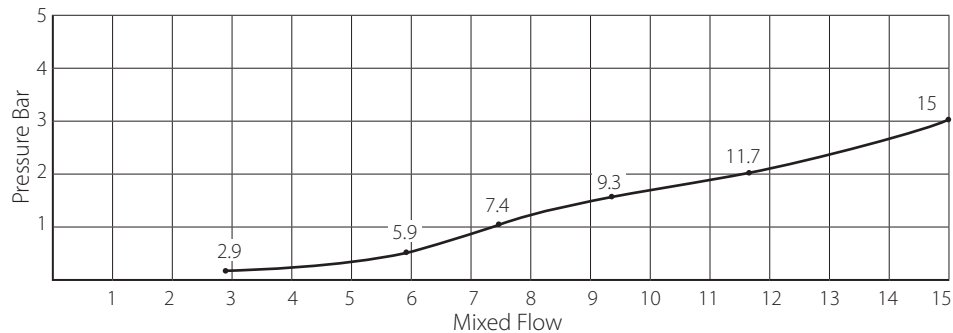

Flow rate curve is for reference only. The actual pressure drop may vary depending on system temperature and pressure.

Recommended outlet temperatures

The BuildCert TMV scheme recommends the following mixed water outlet temperature for use in all premises:

44° C for bath fill but see notes below;

41° C for showers;

The mixed water temperatures must never exceed 46° C.

The maximum mixed water temperature can be 2° C above the recommended maximum set outlet temperature.

Note:

46° C is the maximum mixed water temperature from the bath tap. The maximum temperature takes account of the allowable temperature tolerances inherent in thermostatic mixing valves and temperature losses in metal baths.

It is not a safe bathing temperature for adults or children.

The British Burns Association recommends 37° to 37.5° C as a comfortable bathing temperature for children. In premises covered by the Care Standards ACT 2000, The maximum mixed water outlet temperature is 42° C.

temperature resetting

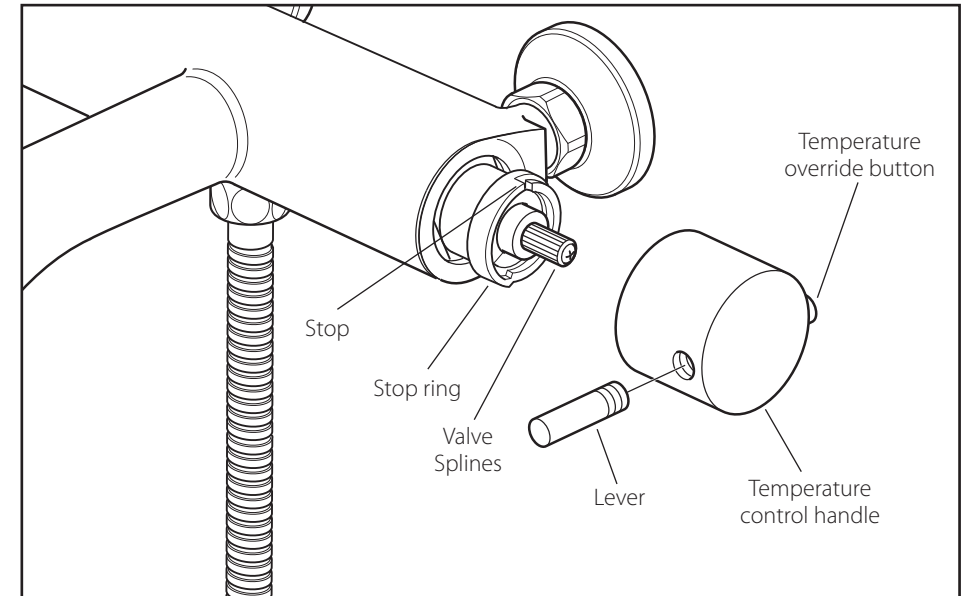

operation

In the off position.

Turning the handle forward will operate the bath spout, and turning the handle backwards will operate the handset.

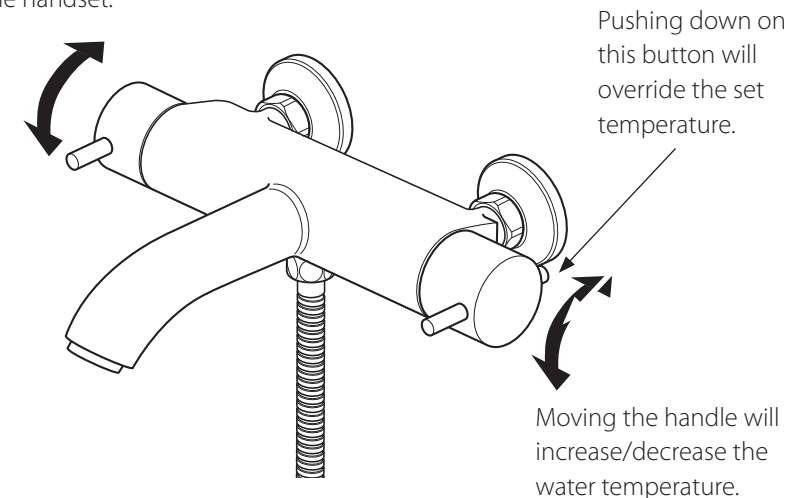

commissioning & temperature resetting

Please ensure that the commissioning of the valve is done under normal operating conditions. The Vado CEL-123T Thermostatic Mixing Valve is supplied factory set at 38° C. To alter this setting, proceed as follows.

Note: mix water temperature at terminal fitting should never exceed 46° C.

The valve has been factory set under balance pressures and hot water supply at 65° C. When your specific operating conditions are significantly different from the above, the temperature of the water may vary from the setting.

When the difference is too great, you can adjust the calibration of the valve to suit individual requirements of the installation:

1. Select 38° C or the arrow on the handle and check the temperature of the water being delivered to the outlet with a thermometer.
2. If the temperature is unacceptable proceed to reset the calibration as follows: Remove the temperature control handle by unscrewing and removing the lever, using the supplied hexagonal key loosen the grub screw and pull off the handle (do not remove the plastic stop ring). Turn the spline of the valve clockwise to decrease the temperature and anti-clockwise to increase the temperature until 38° is achieved.
3. Ensure that the stop on the stop ring is at 12 o'clock and replace the handle with the temperature override button also pointing at 12 o'clock being careful not to turn the spline of the valve. The valve setting is now calibrated to suit your requirements.

A digital hand-held thermometer should be used to measure the outlet temperature correctly which must not exceed 38° C.

Once the correct outlet temperature has been achieved, the valves internal mechanism should be exercised at least three times by alternately isolating the hot and cold supplies. This will cause the piston to travel its full stroke and will ensure that the valve is operating correctly. If the set temperature has drifted after this operation, then the commissioning operation should be repeated.

Once the valve has been commissioned, a fail-safe shut off test should be performed. Isolate the cold supply. The flow should reduce to a trickle within a couple of seconds depending on site conditions.

If the temperature has not altered, repeat the test for the hot supply. If either fail-safe function does not operate, ensure that supply pressures and temperatures are within the valves normal operating parameters. In addition, check that the hot supply temperature is at least 10° C above the valves set mixed outlet temperature, i.e. hot to mix differential temperature.

If this is not the case, then the valve will be slow to shut down on cold water failure.

For optimum performance, it is recommended that the dynamic pressures be as close as equal as possible. If the dynamic pressures are outside a 10:1 ratio, then a pressure reducing valve should be fitted to the higher supply pressure or, if preferred, the lower supply pressure boosted.

dimensions

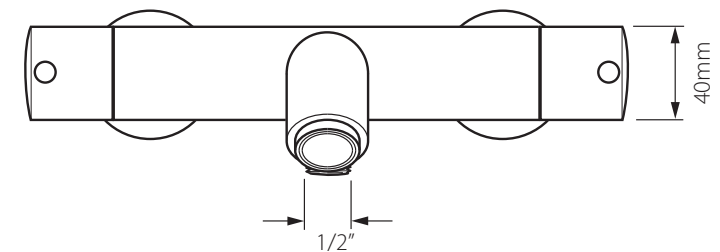
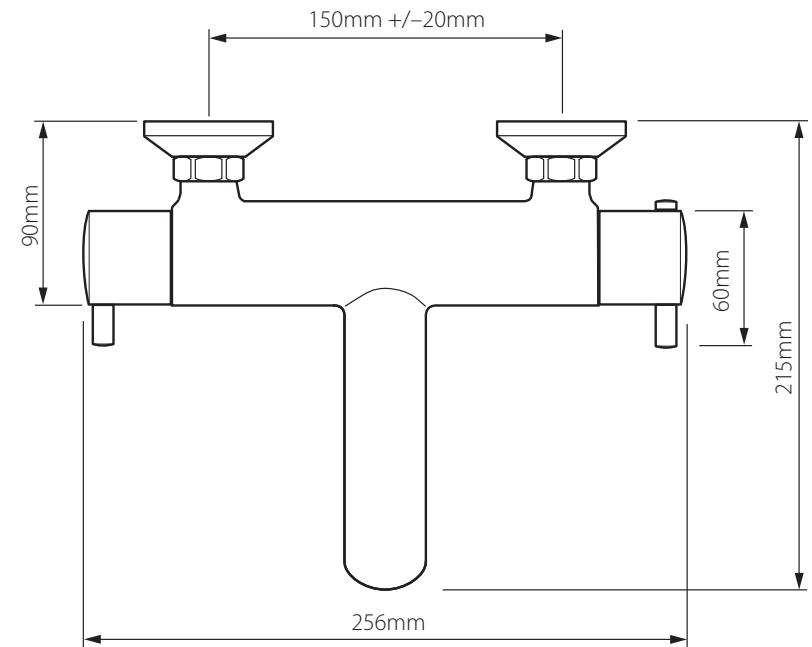

installation

Before Installing the Vado CEL-123T valve, ensure that the designation of the valve matches the application, flow rates, dynamic pressures and temperatures must be within the limits stated.

The Thermostatic mixing valve must be installed in such a position that maintenance of the TMV and its valves and the commissioning and testing of the TMV can be undertaken.

The fitting of isolation valves is required as close as is practicable to the water supply inlets of the TMV.

The Valve should not be installed until the system has been flushed until free of all debris. Once this is done, the strainers and check valves supplied with the valve can be fitted into the adaptors and the valve body installed.

The Vado CEL-123T Thermostatic Mixing Valve contains temperature sensitive components. Soldering near the union adaptors or main valve body must be avoided. The installation of Thermostatic mixing valves must comply with the requirements of the Water Supply (Water Fittings) Regulations 1999.

Rinse pipework carefully for a long while before fitting the valve: do not allow dirt, metal particles or shavings to block the filters fitted on inlets.

Turn off the water supply.

⚠ Warning! Please check for any hidden cables and pipes before drilling holes in the wall.

Prepare the wall with 2 flush $\frac{1}{2}$ " connectors at 150mm centres. Connect the water supply to the inlet pipes. The hot water should be connected to the left hand pipe.

Screw on the 2 offset connectors followed by the covers.

Place a filter/washer in each of the locking nuts on the valve and screw onto the connectors, some adjustment can be made to the offset connectors to align the centres and level up the valve.

Note: The valve must be connected to rigid pipework for support as there are no backnuts or fixing holes.

installation

